

# Solar Thermal Flat Plate Collectors FKC-1

## Rack System for Flat Roof and Wall Installation



**BOSCH**

### Installation Manual for Contractors

6 720 614 820 (2009/12) US/CA



<b>1</b>	<b>General</b>	<b>3</b>
<b>2</b>	<b>Specifications</b>	<b>4</b>
<b>3</b>	<b>Safety</b>	<b>5</b>
3.1	Intended use	5
3.2	Guideline of Notices	6
3.3	Please observe these safety instructions	6
<b>4</b>	<b>Before installation</b>	<b>7</b>
4.1	General notes	7
4.2	Component description	8
4.3	Other equipment needed for the installation	10
4.4	Transport and storage	10
4.5	Technical documentation	11
4.6	Determining the inclination for the collectors	11
4.7	Determining space requirements	14
<b>5</b>	<b>Installing racks on flat roofs and walls</b>	<b>17</b>
5.1	Distances between collector triangles	18
5.2	Clearances between the collector triangles when using ballast trays (accessory)	19
5.3	Stablizing the flat roof rack	21
5.4	Wall mounting racks - installation	24
5.5	Installing the profile rails	25
<b>6</b>	<b>Collector installation</b>	<b>28</b>
6.1	Preparing to install the collectors	29
6.2	Attaching the collectors	31
<b>7</b>	<b>Collector sensor connection</b>	<b>35</b>
<b>8</b>	<b>Hydraulic connection</b>	<b>37</b>
8.1	Pipe bracket	37
8.2	Hydraulic collector connection without an air vent	38
8.3	Hydraulic collector connection with an air vent (accessory)	38
8.4	Connecting two arrays	40
<b>9</b>	<b>Final activities</b>	<b>41</b>
9.1	Checking the installation	41
9.2	Insulating the pipes	41
<b>10</b>	<b>Quick reference guide for mounting and pressure filling</b>	<b>42</b>
<b>11</b>	<b>Spare parts</b>	<b>43</b>
<b>12</b>	<b>Certification</b>	<b>53</b>

# 1 General

This chapter details which technical rules and regulations apply to this installation.



## NOTICE

Observe all standards and guidelines applicable to the installation and operation of this system in your country. Installations must be made in accordance with all codes and regulations applicable to the installation site.

## Lightning protection

If the solar equipment protrudes above the roof ridge or the building height (installation height) exceeds 66 ft (20 m), it is recommended to have lightning arrestors installed on the tallest equipment including the solar collectors.

## 2 Specifications

FKC		
Certificates		
Length		81-1/2 in (2,070 mm)
Width		45-1/8 in (1,145 mm)
Depth		3-1/2 in (90 mm)
Clearance between collectors		1 in (25 mm)
Absorber contents, Portrait version	$V_f$	0.2 gal (0.9 l)
Absorber contents, Landscape version	$V_f$	0.33 gal (1.25 l)
Gross absorber surface area	$A_G$	26 ft <sup>2</sup> (2.41 m <sup>2</sup> )
Net absorber surface area		24.29 ft <sup>2</sup> (2.26 m <sup>2</sup> )
Net weight, Portrait version	m	91 lbs (41 kg)
Net weight, Landscape version	m	93 lbs (42 kg)
Permissible operating pressure of the collector	$P_{max}$	87 psi (6 bar)

Tab. 1 Specifications

## 3 Safety

This chapter explains the meaning of the notes you will find in this manual and provides general safety instructions for safe and trouble-free operation.

You will find the installation-specific safety and user notes next to the appropriate installation steps.

Carefully read the safety instructions before commencing the installation.

Severe injury and even death, as well as property damage and environmental damage, may result if you ignore safety instructions.

### About this manual

This installation manual contains important information for the safe and intended installation of sloped roof mounting systems as well as plumbing connections.

The illustrations in this manual show Portrait collectors. Instructions for Landscape collectors are the same as for Portrait unless stated otherwise.

These technical documents should be retained in a safe place.

The activities described in the installation manual assume expertise based on completed vocational training in plumbing. Only carry out these installation steps if you possess these skills.

- ▶ Hand these installation instructions to the building owner.
- ▶ Explain to the customer the function and operation of the related devices.

### 3.1 Intended use

Install components only on roofs with sufficient strength and capacity. Take the additional load per flat roof rack, including solar collector, wind and snow, into consideration.

If necessary, ask a structural engineer for assistance.

Only install this system on flat roofs or roofs with a shallow pitch ( $\leq 25^\circ$ , less than a 12/6 pitch).

If there is a risk that larger quantities of snow accumulate behind the collectors (towards the roof ridge), prevent this by fitting a suitable protective grille.

#### Application conditions for flat roof racks

The mounting system is suitable for a max. standard snow load of 42 lbs/sqft (2.0 kN/m<sup>2</sup>), a building height of max. 66 ft (20m), and a max. wind speed of 81mph (129 km/h). Using appropriate accessories, the installation set can be used for a max. standard snow load of 79 lbs/sqft (3.8 kN/m<sup>2</sup>), a max. building height of 328 ft (100 m), and a max. wind speed of 94 mph (151 km/h).

Do not attach any other devices, e.g. antennas, to collector racks.

#### Wall mounting

Landscape collectors can be installed on vertical walls using the same mounting racks. Wall installation of Portrait collectors is not permitted. Ensure that the wall is structurally sound and capable of bearing the load. It is recommended to consult a structural engineer.

Wall mounted collectors are suitable for wind speeds up to of 81mph (129 km/h), a maximum installation height of 66 ft (20 m) and a maximum snow load of 42 lbs/sqft (2.0 kN/m<sup>2</sup>).

Ensure that falling rain water, snow, and ice do not cause a nuisance or hazard below.

### 3.2 Guideline of Notices

Two levels of danger are identified by the following symbols:



**WARNING!**

#### **DANGER**

Denotes a possible severely dangerous situation where, without proper caution, bodily injury or loss of life may result.



**CAUTION!**

#### **DANGER OF INJURY/SYSTEM DAMAGE**

Denotes a possible dangerous situation that can lead to mild to moderate bodily injury or property damage.

Additional symbol for designating user notes:



#### **NOTICE**

Application comment for optimum use of equipment and adjustment as well as useful information.

### 3.3 Please observe these safety instructions



**WARNING!**

#### **RISK OF LIFE**

from a fall or falling parts.

- ▶ Take appropriate safety measures to prevent accidents when working on roofs.
- ▶ While working on the roof, take all necessary precautions against a possible fall.
- ▶ Always wear protective clothing and safety equipment.
- ▶ After completing an installation always verify that all components are installed according to the instructions and are securely attached.



**CAUTION!**

#### **RISK OF INJURY**

Personal injury and system faults can result from altered construction.

- ▶ Never modify structural elements.
- ▶ Never drill additional holes.
- ▶ Never attach non-system related components (e.g. antennas).



**CAUTION!**

#### **RISK OF INJURY**

Solar system components can become very hot even when a system is decommissioned.

- ▶ Always wear protective clothing and safety equipment.
- ▶ Cover the collector (collector covers are available as an accessory) during installation to prevent high temperatures resulting from solar radiation.



**CAUTION!**

Observe maximum load and distance from edges before installing the substructure supports to the roof. If necessary, consult a structural engineer to determine if the structure is suitable for installing solar collectors, including expected snow and wind loads.



**CAUTION!**

Solar pipes and solar fluid can cause severe burns. Extreme caution must be taken when a system is in stagnation.



**CAUTION!**

#### **SYSTEM DAMAGE**

Avoid scratching or sudden shocks to the glass of a solar panel. Never step or walk on collectors.



**CAUTION!**

Never braze or solder in close proximity of a solar panel.



**CAUTION!**

Install a heat exchanger to separate pool water or potable water from the collector system.



**CAUTION!**

The use of heat transfer fluid "Tyfocor L, Tyfocor LS and Tyfocor L "G" " is strongly recommended. For more detailed information about suitable solar heat transfer fluids refer to the installation instruction of the KS pump stations.



**CAUTION!**

This system is not suitable for drain back installations. Only closed loop pressurized systems are permitted.

## 4 Before installation

### 4.1 General notes



#### NOTICE

It is recommended to consult a roofing company, as they are experienced in working on roofs and are equipped with the necessary personal safety equipment. Roofers also are experienced with attaching equipment to the roof and making proper penetrations.

Make yourself familiar with the on-site conditions and local regulations before commencing the installation.

#### Check

- ▶ the delivery for completeness and perfect condition.
- ▶ the roof structure for sufficient strength and possible damage (e.g. leaks).
- ▶ the building height and determine the type and number of attachment points required (see Section 5.3 "Stablizing the flat roof rack", page 21).
- ▶ the optimal arrangement of the solar collectors. Take into consideration the orientation of the building toward the sun, any tall trees, adjacent buildings, building features, etc.
- ▶ where the penetration(s) into the building envelope are located and arrange the collector array accordingly.
- ▶ if the collector array can be arranged symmetrically with the building and building features.
- ▶ the stability of the support surface. Remove gravel or similar material.



#### NOTICE

Only use OEM components and replace any defective or damaged parts immediately.



#### NOTICE

It is recommended to consult a professional roofer if roof repairs are necessary. Have the work completed before installing the solar equipment.

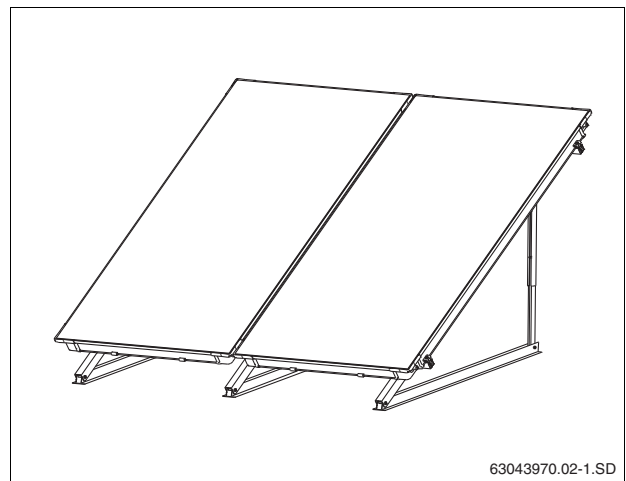

Fig. 1 Flat roof mounted collectors

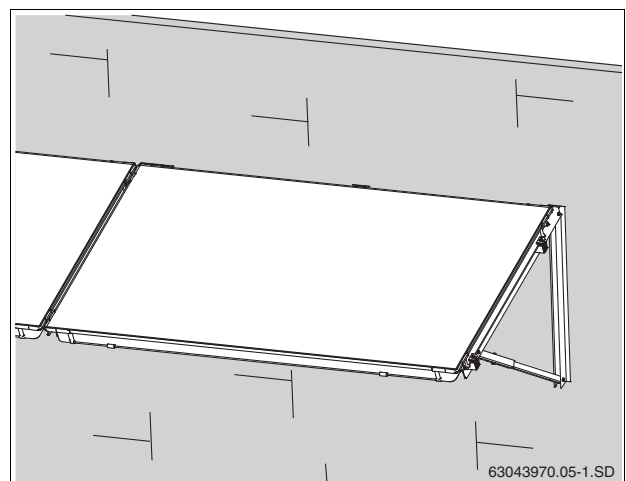

Fig. 2 Wall mounted collectors

## 4.2 Component description

### 4.2.1 Collector racks

The collectors are attached to horizontal rails that are mounted on triangular racks. The inclination of the racks is adjustable to match the desired angle of insolation.

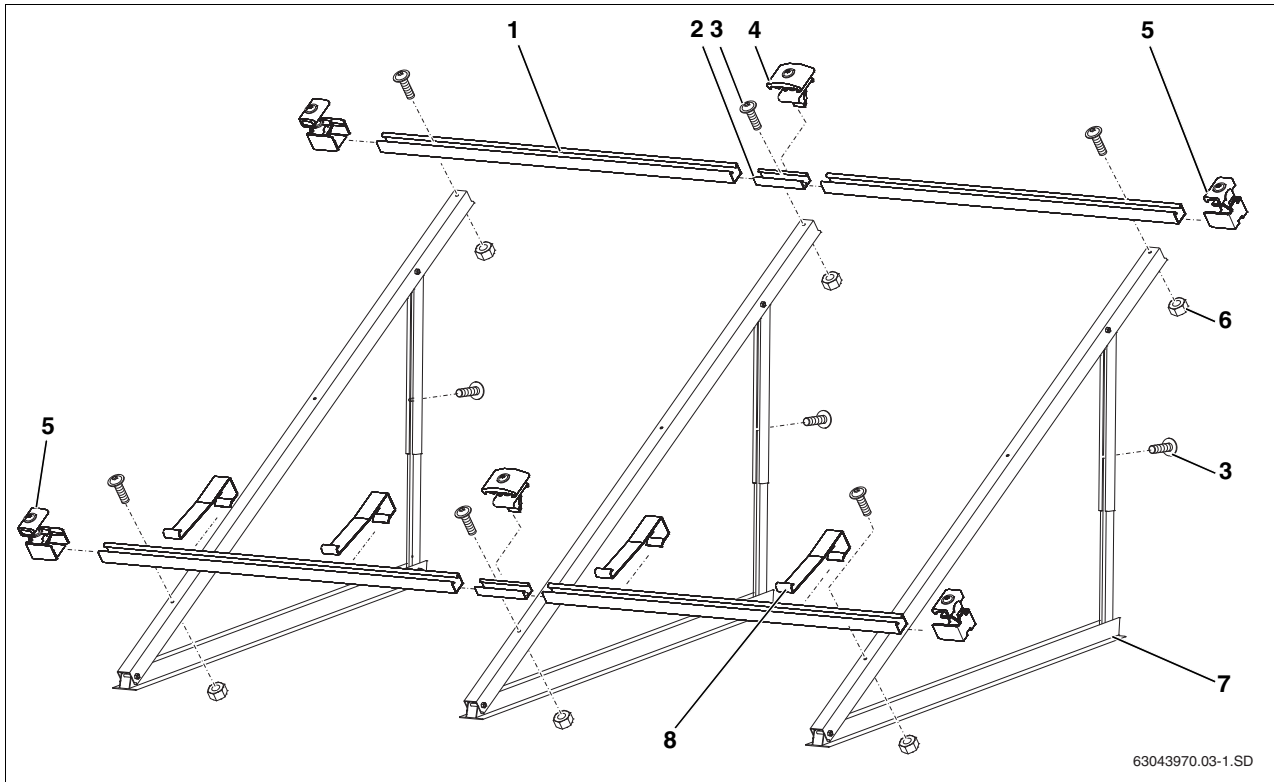

Fig. 3 Rack set for 2 collectors - 1 basic rack, 1 extension rack

#### Basic rack for each collector array including the first collector (Fig. 3):

1	Horizontal rail	2 ×
3	M8 screw × 20	6 ×
5	Single-sided collector clamp	4 ×
6	M8 nut	4 ×
7	Bottom rail	2 ×
8	Collector hanger	2 ×

#### Extension rack for each additional collector (Fig. 3):

1	Horizontal rail	2 ×
2	Rail connector	2 ×
3	M8 screw × 20	3 ×
4	Double-sided collector clamp	2 ×
6	M8 nut	2 ×
7	Bottom rail	1 ×
8	Collector hanger	2 ×



#### NOTICE

For higher snow and wind loads, auxiliary braces and additional horizontal rails are needed.

### 4.2.2 Hydraulic connection

For the hydraulic connections the connection kit is needed. The parts used to connect two collectors are included in two of the corner protectors of each collector's packaging.

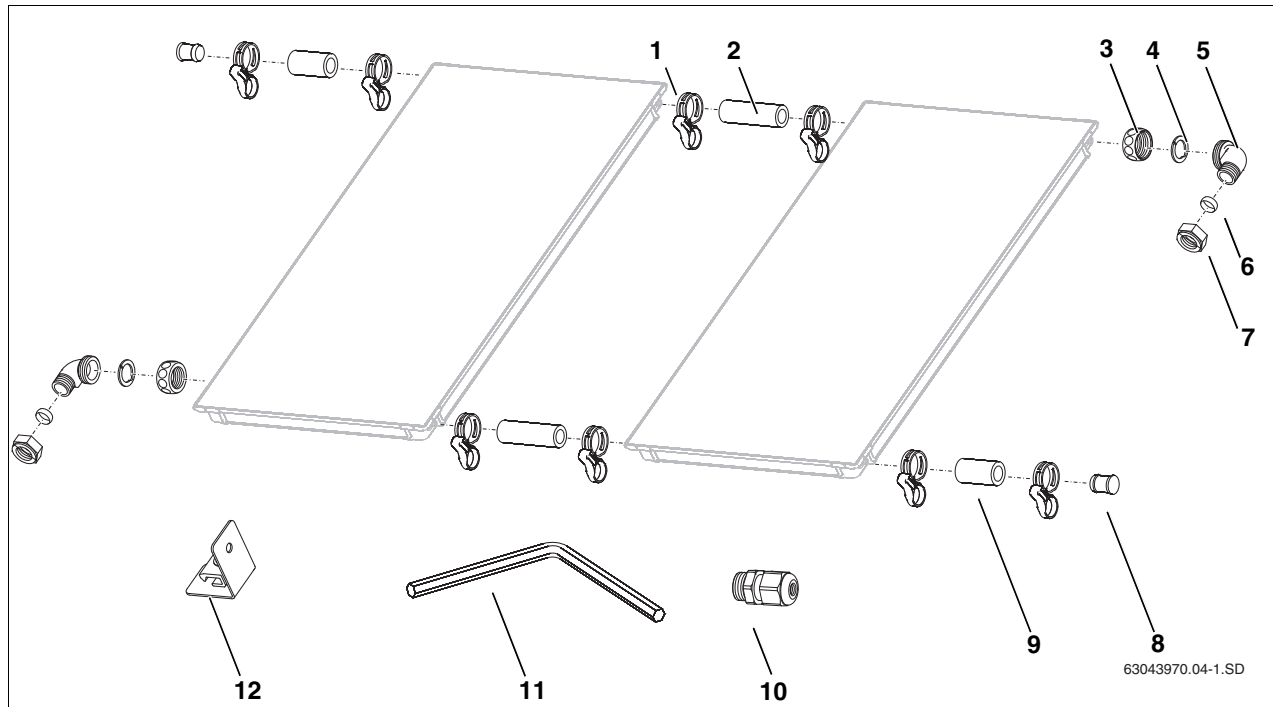

Fig. 4 Connection kit

#### Connection kit, per collector array (Fig. 4)

1	Hose clamp (incl. 1 spare)	5 ×	7	Compression nut $\frac{3}{4}$	2 ×
2	Collector connection hose	2 ×	8	Dummy plug	2 ×
3	G1 nut	2 ×	9	Hose	2 ×
4	Washer	2 ×	10	Compression fitting for collector sensor	1 ×
5	Elbow	2 ×	11	Size M5 Allen wrench	1 ×
6	Compression ring $\frac{3}{4}$	2 ×	12	Bracket for routing the supply pipe	2 ×
7	Compression nut $\frac{3}{4}$	2 ×			

#### Connection set between the collectors, for each collector (in two of the collector's protective corners, Fig. 5)

1	Hose clamp	4 ×
2	Collector connection hose	2 ×

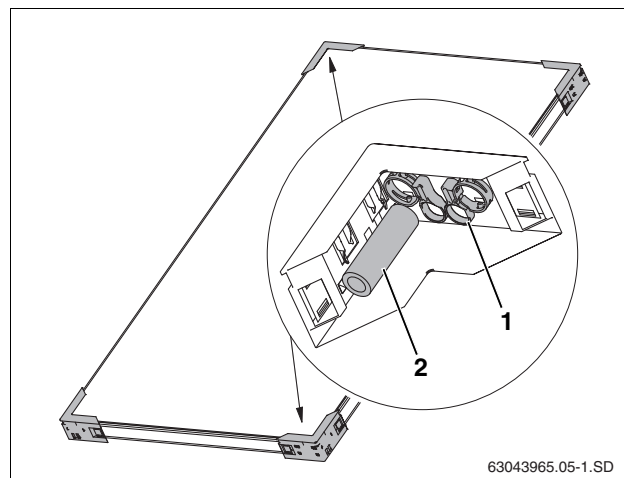

Fig. 5 Two protective corners carry the collector connection sets

### 4.3 Other equipment needed for the installation

- Level
- Rope
- High head filling pump
- Personal protective equipment for on the roof
- Pipe insulation with UV protective coating
- Scaffolding
- Ladder
- Bucket truck or scissor lift
- Equipment for attaching the racks to the roof or substructure

### 4.4 Transport and storage

All components are protected by transport packaging.



#### NOTICE

Dispose of the transport packaging in an environmentally friendly manner.

#### Transport protection for collector connections

The collector connections are protected against damage by rubber caps.



CAUTION!

#### SYSTEM DAMAGE

from damaged gaskets.

- ▶ Do not remove the rubber caps (Fig. 6, [1]) until immediately prior to installation.

#### Storage

The collectors must be stored in dry conditions.



#### NOTICE

Do not store collectors outside without protection from the weather. The packaging is not designed to be all weather proof.

Protect the collectors using a tarp during transport in wet weather in an open truck.

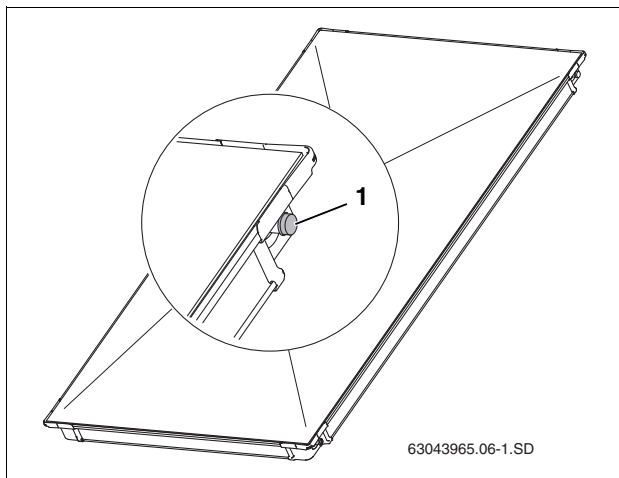

Fig. 6 Rubber caps on collector connections

## 4.5 Technical documentation

The solar system consists of various components (Fig. 7). Installation, operation and maintenance documentation is provided for each component. If needed accessories are accompanied by a separate document.

- Item 1:** Collector: instructions for flat roof mounting are enclosed with the connection kit
- Item 2:** Pump station: instructions enclosed with the pump station
- Item 3:** DHW storage tank: instructions enclosed with the DHW storage tank

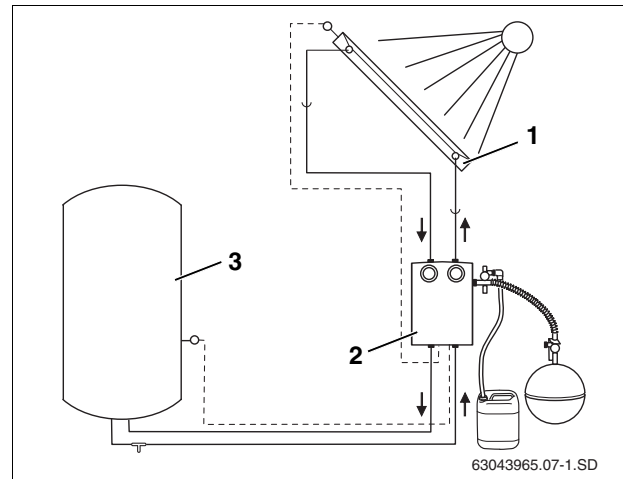

Fig. 7 Solar system components and technical documentation

## 4.6 Determining the inclination for the collectors

The collectors' inclination depends on the application. It can be adjusted using the telescopic rails (Fig. 8).

### 4.6.1 Determining the application

Depending on the application different collector inclinations are chosen. See tab. 2 for recommendations.

Applications	Inclination
DHW	30 – 45°
Domestic hot water + central heating	45 – 60°
Domestic hot water + swimming pool	30 – 45°
Domestic hot water + central heating + swimming pool	45 – 60°

Tab. 2 Area of application, inclination range



### NOTICE

Above tab. 2 is valid for areas at 40-60° Latitude. For areas further north steeper angles, and further south shallower angles are recommended.

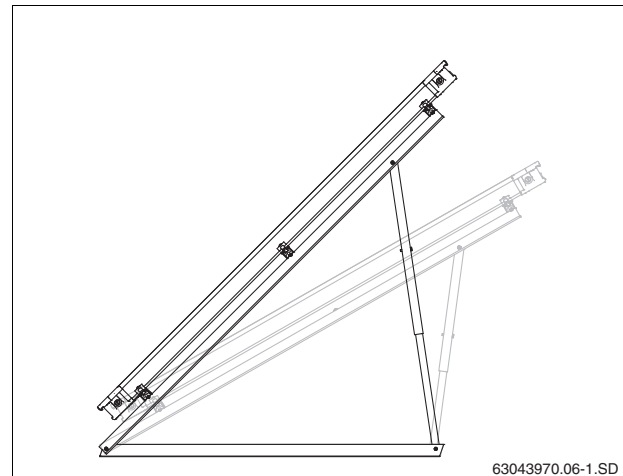

Fig. 8 Inclination of the collector on a flat roof

### 4.6.2 Sloped roofs

On roofs that slightly sloped in a southerly direction, the pitch angle is deducted from the inclination. On roofs slightly sloped in a northerly direction, the pitch angle is added to the inclination (Fig. 9).



**WARNING!**

#### RISK TO LIFE

If there is a risk that larger quantities of snow accumulate underneath the collectors, install a suitable protective grille on site.



**CAUTION!**

#### SYSTEM DAMAGE

from strong winds. On sloped roofs racks must be permanently secured to the roof. Ballast trays are only permitted as additional means.

- ▶ It is recommended to consult a professional roofer when installing collector racks on a sloped roof.

### 4.6.3 Walls

The collector racks can also be used for wall-mounting.



**WARNING!**

#### RISK TO LIFE

from falling collectors, due to improper attachment.

- ▶ The collector inclination (Fig. 10, [1]) to the horizontal must be between  $45^\circ$  and  $60^\circ$ . The angle between the collectors and the wall (Fig. 10, [2]) must be between  $30^\circ$  and  $45^\circ$ .

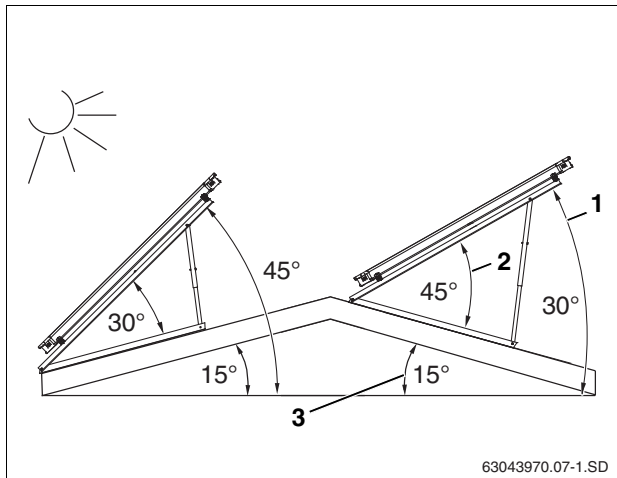

Fig. 9 Inclination of the collector on a flat roof

- 1 Inclination (absolute angle to the horizontal plane)
- 2 Collector angle over the roof
- 3 Roof pitch

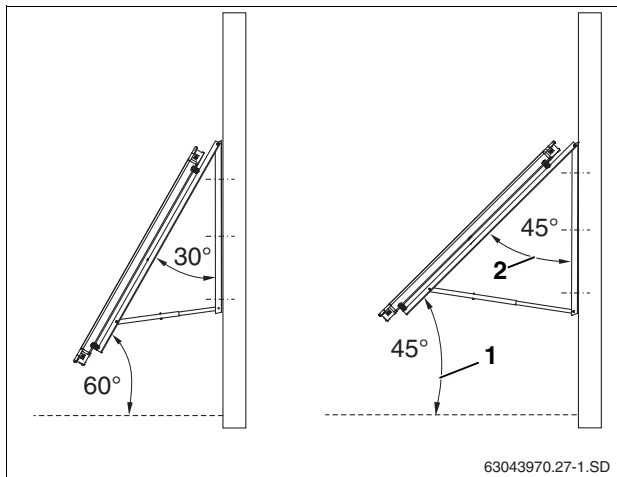

Fig. 10 Permitted inclination of the collector on a wall

- 1 Inclination to the horizontal plane
- 2 Angle to the wall

#### 4.6.4 Telescopic rails

The inclination is set using the telescopic rails.

- ▶ Select holes on the upper and lower telescopic rails as shown in Fig. 12 and Fig. 13.
- ▶ Insert telescopic rails into each other and fasten with an M8 × 20 screw (Fig. 11).

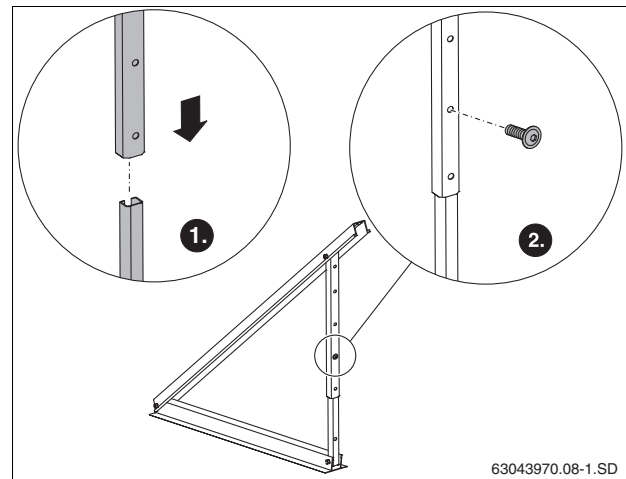

Fig. 11 Connecting telescopic rails



#### NOTICE

For Portrait collectors of a collector with an inclination of 30° to 60°, use the uppermost hole on the lower telescopic rail (Fig. 12, [1]).

For an inclination of 25°, shorten the top of the lower rail by 5-1/2 inches (140 mm) and use the lower hole (Fig. 12, [2]).

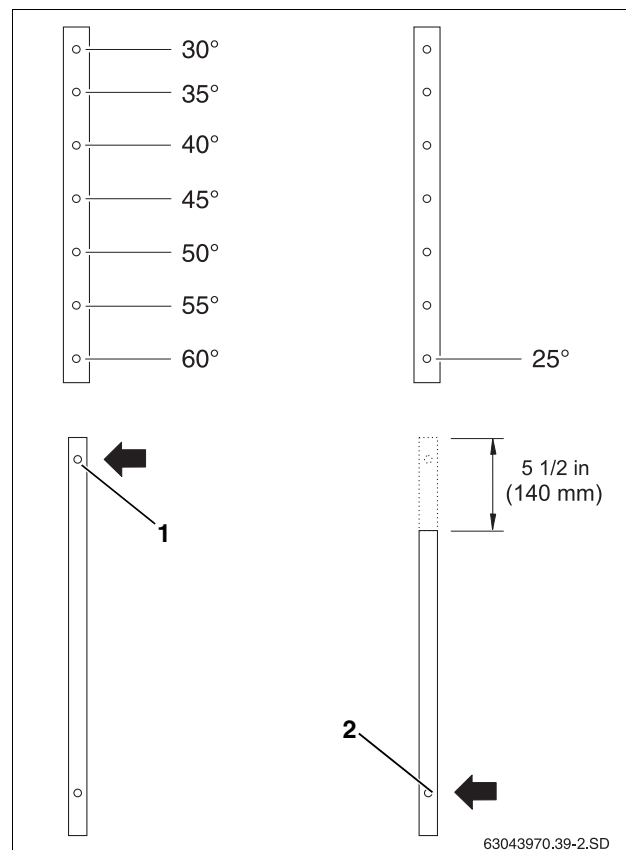

Fig. 12 Adjustment angle for Portrait collectors



**NOTICE**

For Landscape collectors with an inclination of 35° to 60°, use the uppermost hole on the lower telescopic rail (Fig. 13, [3]).

For an inclination of 25° and 30°, shorten the top of the lower rail by 5-1/2 inches (140 mm) and use the lower hole (Fig. 13, [2]).



**WARNING!**

**RISK TO LIFE**

from falling collectors, due to improper attachment.

- ▶ For wall-mounted installation, use only the positions for 30°, 35°, 40° and 45° (Fig. 13, [1]).

**4.7 Determining space requirements**

**4.7.1 Clearance between collector arrays**

The minimum spacing between the collector arrays is determined by the inclination of the collector.



**NOTICE**

When using multi-row arrays, note that the clearance X (Fig. 14) between the arrays must be large enough to avoid shadows falling over adjacent collectors.

Maintain the clearance stated in the tables or calculate the required clearance (Technical Guide).

Inclination – collector	Clearance X	
	Portrait collectors	Landscape collectors
25°	186 in (4.74 m)	103-3/16 in (2.63 m)
30°	204 in (5.18 m)	112-7/8 in (2.87 m)
35°	219-5/8 in (5.58 m)	121-1/2 in (3.09 m)
40°	234 in (5.94 m)	129-5/8 in (3.29 m)
45°	246 in (6.26 m)	136-3/16 in (3.46 m)
50°	256-7/8 in (6.52 m)	141-5/8 in (3.61 m)
55°	264 in (6.74 m)	146-7/16 in (3.73 m)
60°	271 in (6.90 m)	150-7/10 in (3.82 m)

Tab. 3 Required clearance between two collector arrays to avoid shading

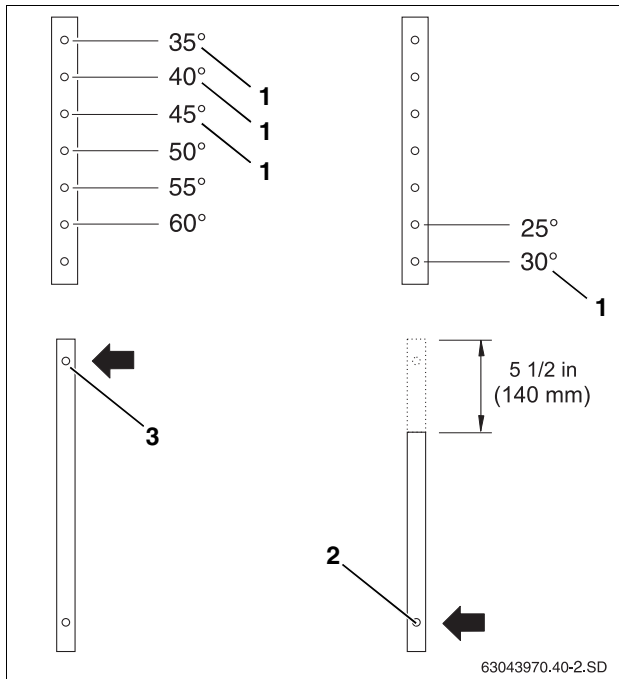

Fig. 13 Adjusting the inclination for horizontal collectors

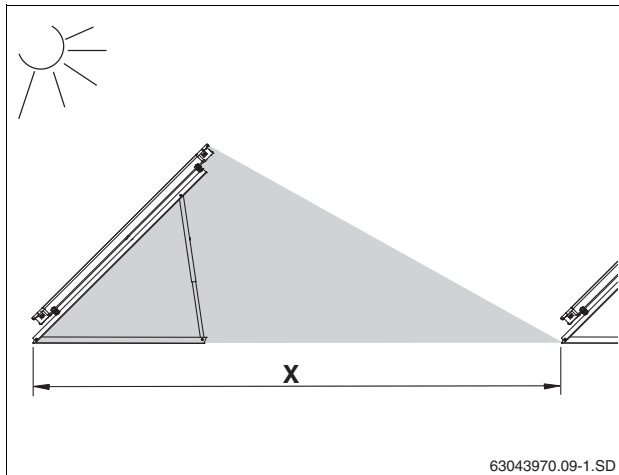

Fig. 14 Shadow – clearance X



### NOTICE

The above angles are valid for 50° Latitude. Greater distances are needed further north, and lesser distances further south.

#### 4.7.2 Estimating your space requirements



**CAUTION!**

### SYSTEM DAMAGE

from wind and pressure peaks around the roof edges.

- ▶ Before commencing the installation, ensure that at least the distances shown in Fig. 15 are clear between the racks and the edge of the roof.

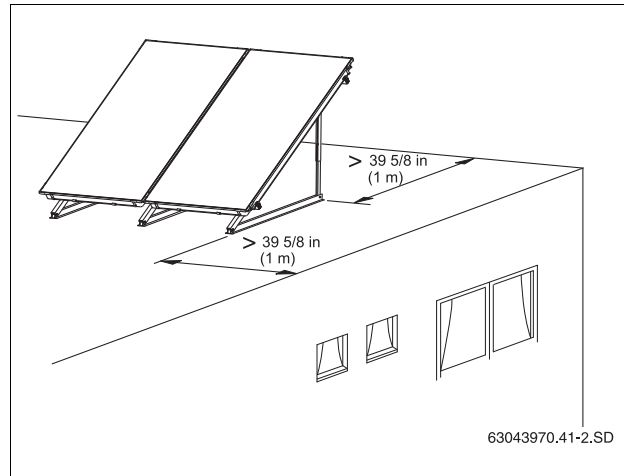

Fig. 15 Distance from the edge of the roof

Allow sufficient space for the different forms of installation (Portrait, Landscape).

These dimensions (Tab. 4 and Tab. 5) relate to the roof surface area which must be available.

The quoted dimensions are simply the width of the collector array. In addition, allow at least 1-1/2 ft (0.5 m) on either side of the collector array for pipework.

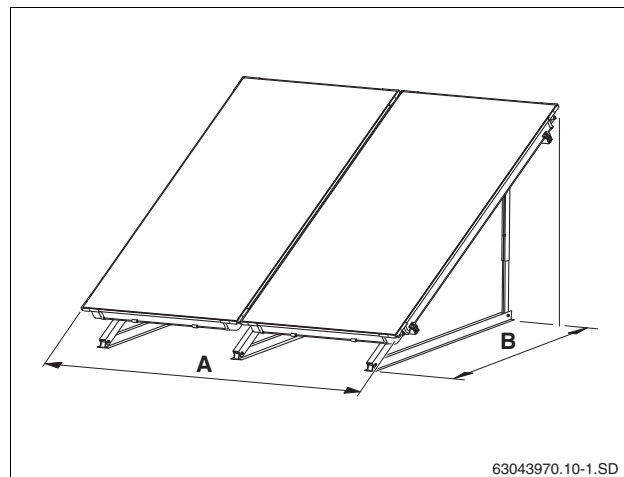

Fig. 16 Space requirements – collector array – Portrait collectors

**Space requirements for Portrait collectors:**

Number of collectors	Dimension A	Inclination	Dimension B
2	7' 8-1/4" (2.34 m)	25°	6' 1/2" (1.84 m)
3	11' 6-1/4" (3.51 m)	30°	5' 9" (1.75 m)
4	15' 4-1/4" (4.68 m)	35°	5' 6-1/4" (1.68 m)
5	19' 2-1/4" (5.85 m)	40°	5' 2-1/4" (1.58 m)
6	23' 1/2" (7.02 m)	45°	4' 10-1/4" (1.48 m)
7	26' 10-1/2" (8.19 m)	50°	4' 10-1/4" (1.48 m)
8	30' 8-1/2" (9.36 m)	55°	4' 10-1/4" (1.48 m)
9	34' 6-1/2" (10.53 m)	60°	4' 10-1/4" (1.48 m)
10	38' 4-3/4" (11.70 m)		

Tab. 4 Space requirement for Portrait collectors

**Space requirements for Landscape collectors:**

Number of collectors	Dimension A	Inclination	Dimension B
2	13' 8-1/2" (4.18 m)	25°	3' 5-3/4" (1.06 m)
3	20' 7-1/4" (6.28 m)	30°	3' 4-1/4" (1.02 m)
4	27' 6" (8.38 m)	35°	3' 1-3/4" (0.96 m)
5	34' 4-1/2" (10.48 m)	40°	3' (0.91 m)
6	41' 3-1/4" (12.58 m)	45°	2' 9-1/4" (0.85 m)
7	48' 2" (14.68 m)	50°	2' 9-1/2" (0.85 m)
8	55' 3/4" (16.78 m)	55°	2' 9-1/2" (0.85 m)
9	62' 11-1/4" (18.88 m)	60°	2' 9-1/2" (0.85 m)
10	68' 10" (20.98 m)		

Tab. 5 Space requirements for Landscape collectors

## 5 Installing racks on flat roofs and walls



**WARNING!**

### RISK TO LIFE

Use appropriate personal protective equipment whenever on a ladder, lift, or the roof.



**WARNING!**

### RISK OF INJURY

from a fall or falling parts.

- ▶ Take appropriate measures to prevent accidents when working on roofs.
- ▶ Always wear your personal protective clothing and safety equipment.



### NOTICE

Observe all national and local safety regulations, as well as the safety instructions in this manual when working on roofs.

Ensure sufficient stability of the installation surface, and remove any gravel and similar material.



### NOTICE

Take measures to protect the roof membrane when working on the roof. It is recommended to consult a professional roofer to ensure the membrane is not damaged.

**This installation method also applies to Landscape collectors.**

The following describes the installation of Portrait collectors. The Landscape version is installed in the same way.

Notes identify any variations.

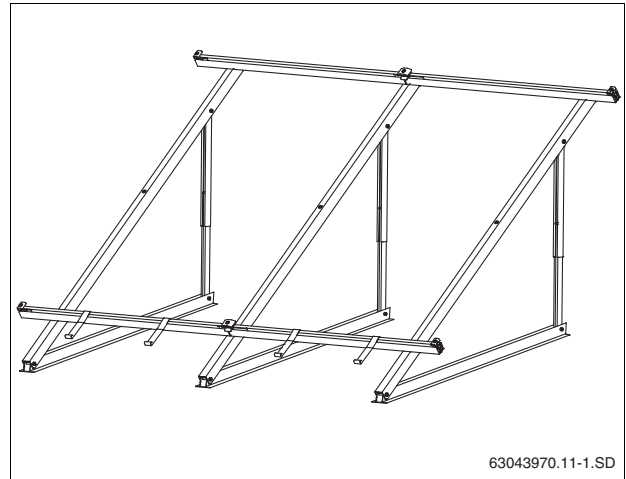

Fig. 17 Flat roof rack for 2 Portrait collectors

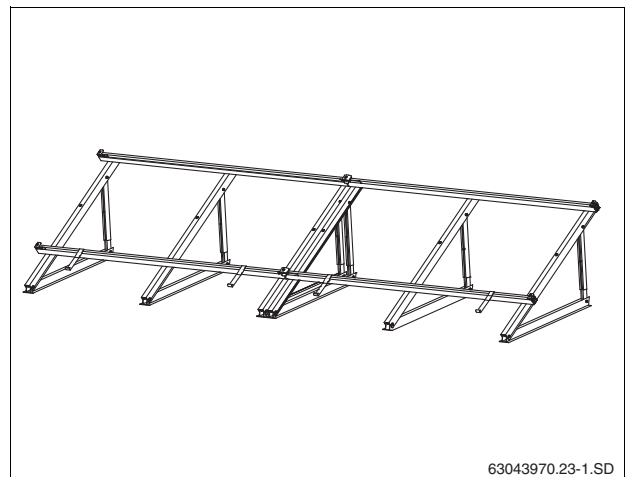

Fig. 18 Flat roof rack for 2 Landscape collectors

## 5.1 Distances between collector triangles

The distances between the collector triangles (center to center) depend on:

- the collector version (Portrait, Landscape)
- and the maximum desired snow and wind loads.



### NOTICE

You must strictly observe the clearances as indicated in Fig. 19 so that the profile rails can still be installed at a later stage.

### 5.1.1 Basic version

Two collector triangles are required for the first collector. For every additional Portrait collector, another collector triangle is required (Fig. 19). For every additional Landscape collector, two collector triangles are required (Fig. 21).

The basic version can be used for the following loads:

- Installation height max. 66 ft (20 m)
- max. 42 lbs/sqft (2.0 kN/m<sup>2</sup>) snow load
- max. 81 mph (129 km/h) wind speeds

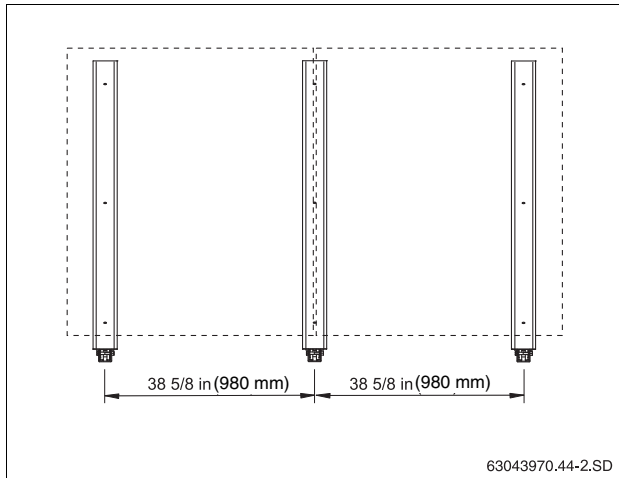

Fig. 19 Basic version for 2 Portrait collectors

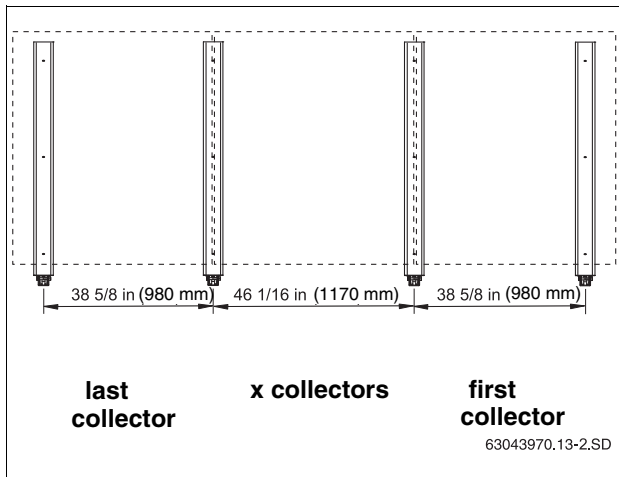

Fig. 20 Basic version for 3 – 10 Portrait collectors

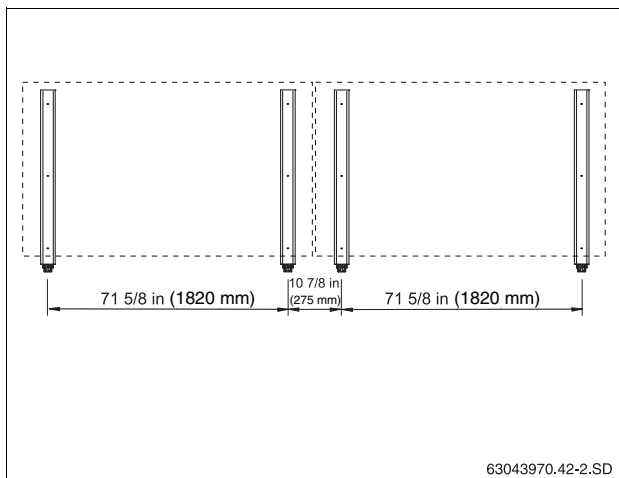

Fig. 21 Basic version for 2 Landscape collectors

### 5.1.2 Additional supports for tall buildings and high wind and snow loads (accessory)

For greater loads, additional supports (and additional profile rails, page 27) are required for Portrait collectors (Fig. 22) and achieves the following loads:

- Building height max. 328 ft (100 m) (installation height)
- max. 79 lbs/sqft (3.8 kN/m<sup>2</sup>) snow load
- max. wind speed of 94 mph (151 km/h)



#### NOTICE

Landscape collectors achieve the same loads using the basic version (Fig. 21), provided that a third profile rail is installed (page 27).

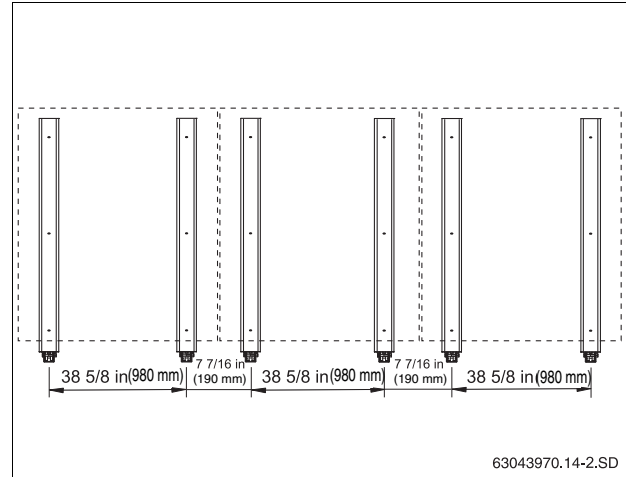

Fig. 22 Auxiliary supports for 3 Portrait collectors

### 5.2 Clearances between the collector triangles when using ballast trays (accessory)



#### NOTICE

Before considering the use of ballast trays verify that the building substructure is capable of supporting the load.



#### NOTICE

Due to the size of the ballast trays, the collector triangles must be spaced exactly 38-5/8" (980 mm) apart. Four trays are fitted underneath each collector.

The distances between the collector triangles (center to center) depend on:

- the collector version Portrait, Landscape
- the maximum snow and wind loads.
- if ballast trays are being used

For Portrait collectors, an additional triangle must be installed for the 4th, 7th and 10th collector in order for the ballast trays to fit (Fig. 23, [1]).

See Tab. 7 for minimum ballast tray weights.

**NOTICE**

Ensure exact placement of the triangles so that the profile rails can be installed.

**5.2.1 Basic version**

The basic version can be used for the following loads:

- Building height max. 66 ft (20 m) (installation height)
- max. 42 lbs/sqft (2.0 kN/m<sup>2</sup>) snow load
- max. wind speed of 81 mph (129 km/h)

Number of collectors	Dimension A	Dimension B	Dimension C
4	15 in (381 mm)	-	-
5	15 in (381 mm)	-	-
6	22 1/2 in (571 mm)	-	-
7	22 1/2 in (571 mm)	15 in (381 mm)	-
8	22 1/2 in (571 mm)	15 in (381 mm)	-
9	22 1/2 in (571 mm)	22 1/2 in (571 mm)	-
10	22 1/2 in (571 mm)	22 1/2 in (571 mm)	15 in (381 mm)

Tab. 6 Distances between triangles

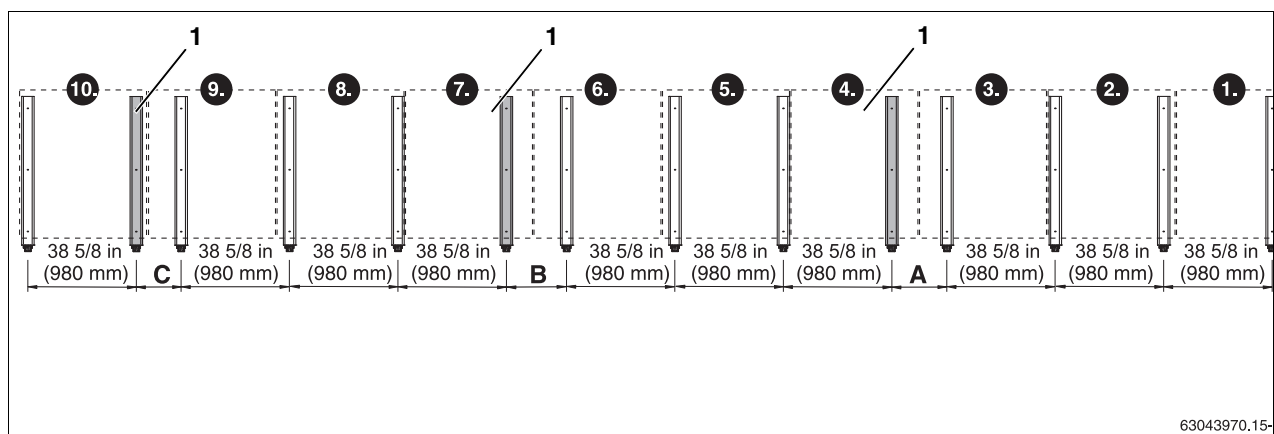

Fig. 23 Basic version for up to 10 Portrait collectors



**NOTICE**

Using concrete blocks or similar material in the ballast trays, a maximum load of 992 lbs (450 kg) may be needed per collector (Tab. 7).

**NOTICE**

For the following table, please also consider the clearances and number of additional triangles (Section 5.1 "Distances between collector triangles").

Stablizing a collector					
Installation height	Wind speed	Base anchor	Weighting	Ropes	
				Securing against tipping	Securing against moving
		Number and type of screws <sup>2, 3</sup>	Weight (e.g. concrete blocks)	Weight (e.g. concrete blocks)	Maximum guy wire tension
0-26 ft (0 to 8 m)	64 mph (102 km/h)	2 × M8/8.8	595 lbs (270 kg)	397 lbs (180 kg)	360 lbs-ft (1.6 kN)
26-66 ft (8 to 20 m)	81 mph (129 km/h)	2 × M8/8.8	992 lbs (450 kg)	705 lbs (320 kg)	562 lbs-ft (2.5 kN)
66-328 ft (20 to 100 m <sup>1</sup> )	94 mph (151 km/h)	3 × M8/8.8	–	992 lbs (450 kg)	742 lbs-ft (3.3 kN)

Tab. 7 Minimum measures to stabilize one collector

<sup>1</sup> With additional profile rail only

<sup>2</sup> Per collector triangle

<sup>3</sup> Or equivalent

### 5.3.1 Securing flat roof racks on site

Attach the flat roof racks with anchor bolts. As an example, see mounting on I-beams (Fig. 26, [3]).

Design the substructure so that the collectors and rack system withstand the snow loads and wind forces they are designed for.

Additional measures may be required on site to stabilize the structure and prevent damage to the roof.



**CAUTION!**

#### SYSTEM DAMAGE

from modifications to the flat roof racks.

- ▶ For example, never drill additional holes in rails and profiles.

- ▶ Transfer the lower horizontal rail hole clearances (Fig. 26, [2]) onto the I-beams, and drill corresponding holes.
- ▶ Insert screws (see Tab. 7 and Fig. 26, [1]) through the profiles and I-beams and tighten with nuts and washers.

### 5.3.2 Securing flat roof racks with ballasts

- ▶ Place collector racks (see Section 5.1 "Distances between collector triangles").
- ▶ Place ballast trays (Fig. 27, [2]) into lower profiles (Fig. 27, [1]) and into each other (Fig. 27, [3]).
- ▶ Insert concrete blocks or similar into ballast trays (for required weight, see Tab. 7). Blocks are stacked to achieve the required weight.

### 5.3.3 Providing extra support for the flat roof racks using guy wire

If needed, install guy wires according to the following description:

Select the type of guy wires depending on the expected loads (see Tab. 7).

- ▶ Attach each collector on site to the bolt on the lower profile and a suitable point on the roof, using at least 2 guy wires (Fig. 28, [1]).

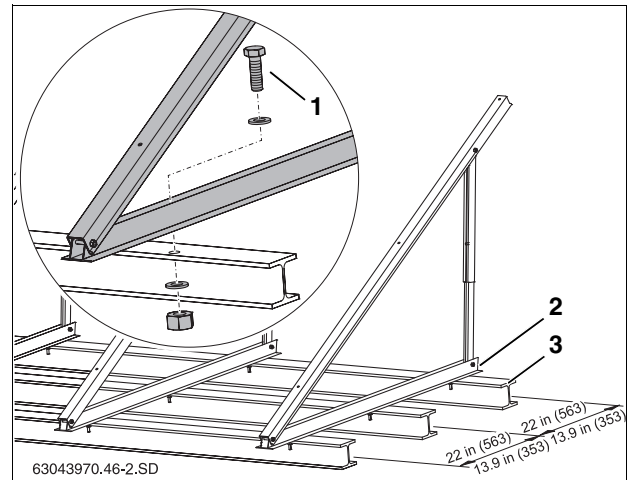

Fig. 26 Flat roof rack on girders, dimensions in mm (value in brackets = Landscape collectors)

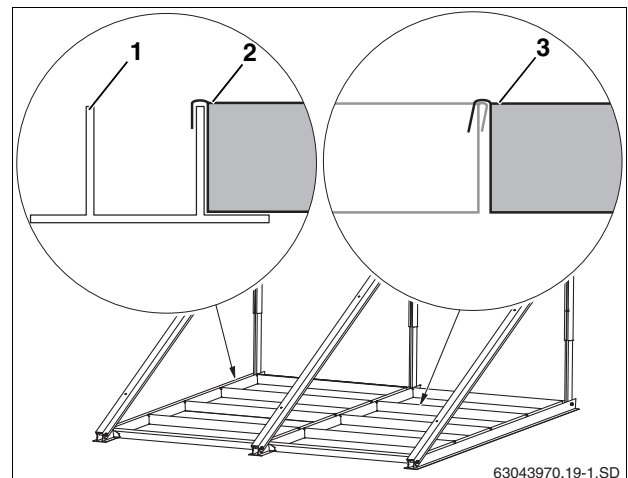

Fig. 27 4 loading trays per collector

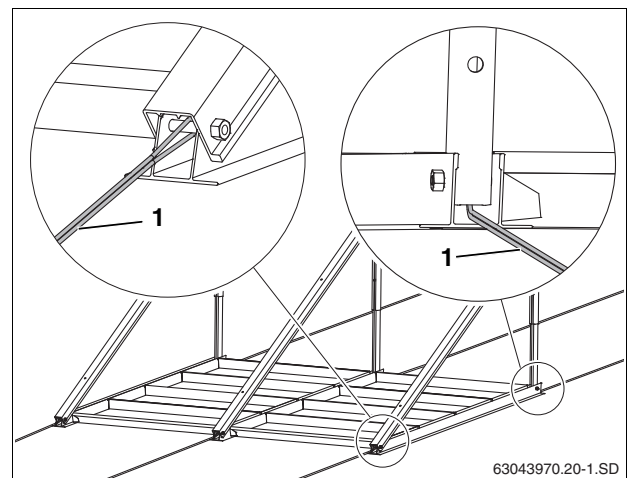

Fig. 28 Flat roof rack with guy wires

## 5.4 Wall mounting racks - installation

The Landscape collector racks are used for wall installation.



### NOTICE

Do not wall mount collectors where falling rain water, snow, and ice can create a nuisance or hazard below.



**WARNING!**

### RISK TO LIFE

from falling collectors, due to incorrect installation.

- ▶ Only Landscape collectors are suitable for wall installation.
- ▶ Collectors may only be installed at a maximum height of 66 ft (20 m) , a maximum expected wind velocity of 81mph (129 km/h) and maximum snow load of 42 lbs/sqft (2.0 kN/m<sup>2</sup>).
- ▶ Each collector brace must be attached using the holes provided, using 3 suitable screws or bolts depending on the wall structure.
- ▶ Install only on a structurally sound outside wall.
- ▶ Before installing the wall mounting racks, check the load-bearing capability of the wall and its base. If necessary, ask a structural engineer for assistance.
- ▶ Never modify the racking system.
- ▶ Never place or mount objects in the space underneath the collector racks, or mount non-related equipment to the racks.
- ▶ Do not close off the sides and bottom of the racks.

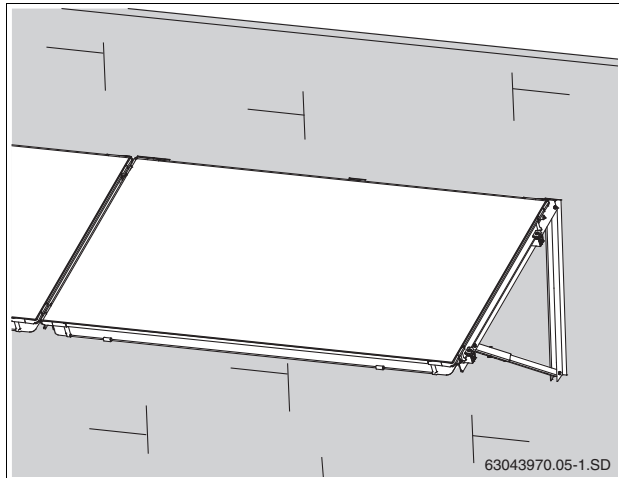

Fig. 29 Wall mounting support

- ▶ Use 3 screws to fasten each collector triangle to the wall (see Tab. 8, Fig. 30, [1]).

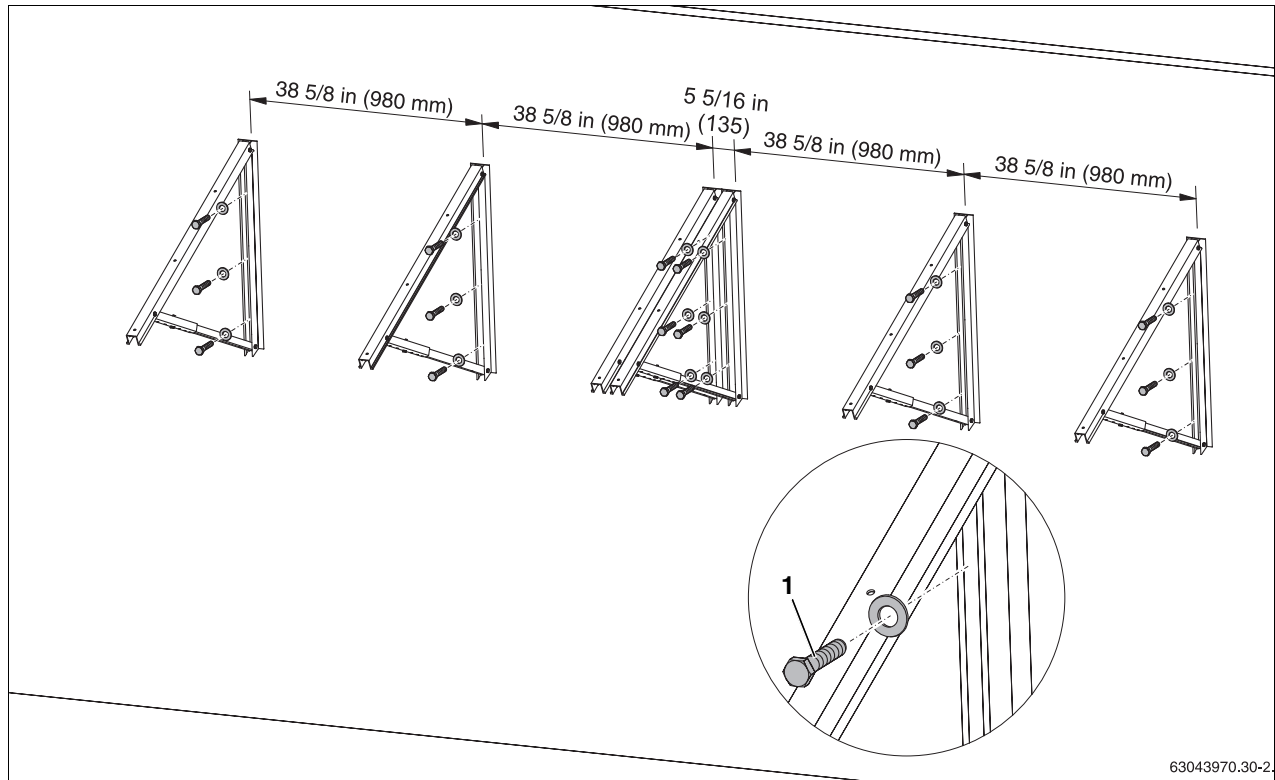

Fig. 30 Attaching the collector rack to the wall (for 2 collectors)

## 5.5 Installing the profile rails

The profile rails must be joined together using the provided connectors. Each collector is attached using an upper and a lower profile rail.

### 5.5.1 Connecting profile rails

- ▶ Push connector (Fig. 31, [1]) as far as it will go into both profile rails (Fig. 31, [2]).
- ▶ To lock, tighten both installed M10 threaded studs (Fig. 31, [3]) in the connector using a size 5 Allen wrench:

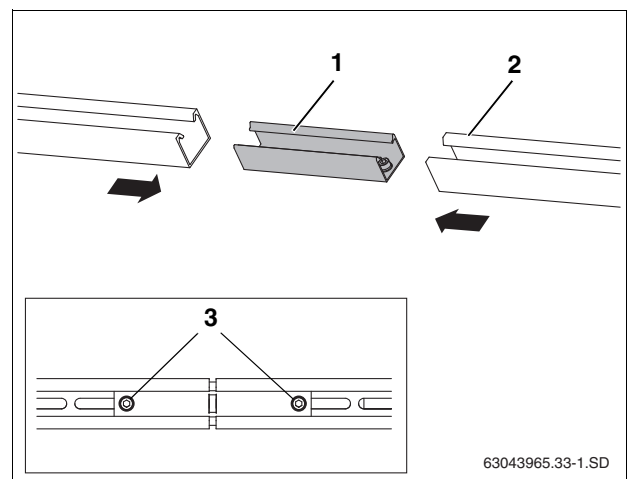

Fig. 31 Connecting profile rails

### 5.5.2 Installing profile rails

Positioning the profile rails depends on

- whether Portrait or Landscape collectors are being installed
- and on the clearances between the collector triangles.

If the racks are bolted to the substructure, begin fastening the profile rails as follows:

	Connected to the substructure	
	Basic version	Auxiliary rack
<b>Portrait:</b>	Align with middle hole on connector (Fig. 32, [1])	Align with second slotted hole from right (Fig. 32, [3])
<b>Landscape:</b>	Align with third slotted hole from right (Fig. 32, [2])	--

Tab. 8 Aligning the lower and upper profile rails when connecting the racks to the substructure

If using ballast trays, begin fastening the profile rails as follows:

	Loading trays	
	2 collectors	3 to 10 collectors
<b>Portrait:</b>	Align with middle hole on plug connector (Fig. 33, [1])	Align with sixth slotted hole from right (Fig. 33, [2])
<b>Landscape:</b>	Align with second slotted hole from right (Fig. 33, [3])	Align with second slotted hole from right (Fig. 33, [3])

Tab. 9 Aligning the lower and upper profile rails when using ballast trays

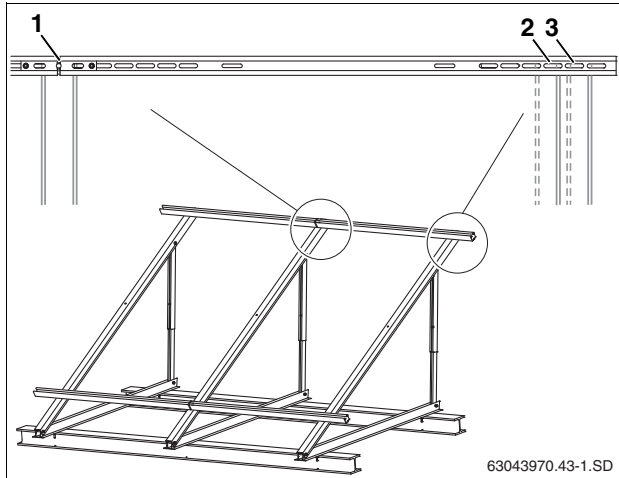

Fig. 32 Aligning the profile rails when connected to the substructure

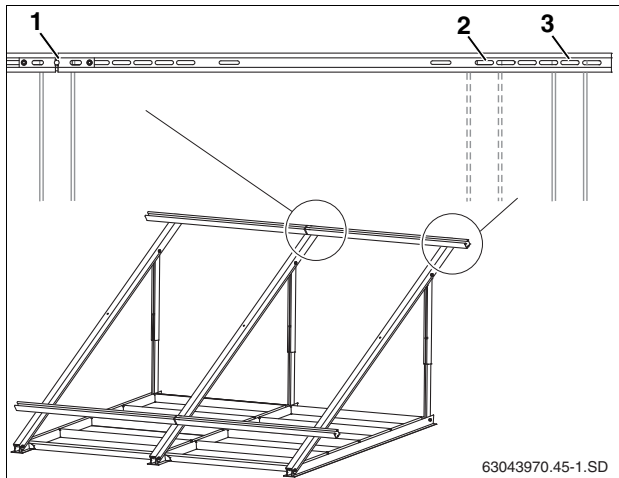

Fig. 33 Aligning the profile rails for ballast trays

- ▶ Lightly tighten the pre-assembled profile rails (Fig. 34, [2]) with M8 x 20 bolts (Fig. 34, [1]) so that the profile rails can still be shifted.
- ▶ Align the sides of the upper and lower profile rails symmetrically.
- ▶ Tighten bolts.

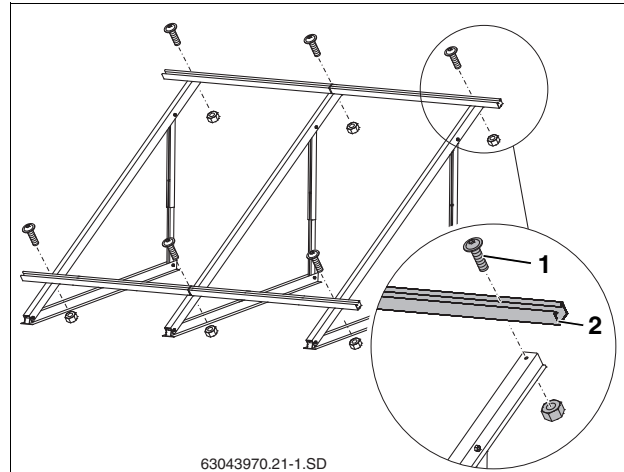

Fig. 34 Installing profile rails (for two Portrait collectors in this example)

### 5.5.3 Installing additional profile rails (accessory)

If the collector array is exposed to greater loads installation height over 66 ft (20 m), snow load over 42 lbs/sqft (2.0 kN/m<sup>2</sup>) and/or wind load up to 91 mph (151km/h), additional rails must be installed.

- ▶ Fasten additional profile rails as described in Section 5.5.2 "Installing profile rails", using the middle hole on the triangle (Fig. 35, [1]).
- ▶ Align the profile rails symmetrically.
- ▶ Tighten bolts.

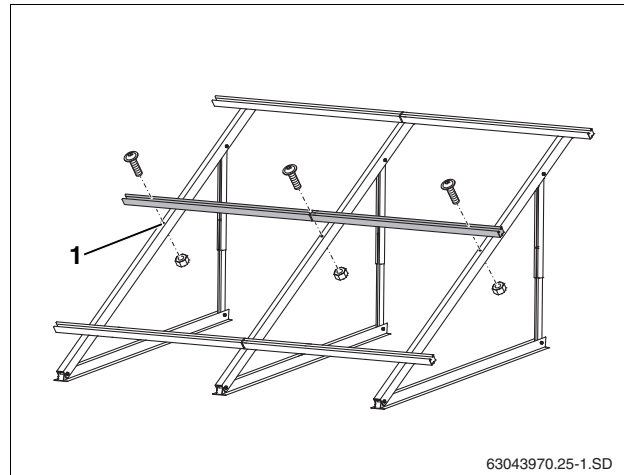

Fig. 35 Installing additional profile rails

### 5.5.4 Installation of collector hanger

Two hanger are installed on the lower profile rail to hold the weight of the collector.

- ▶ Push each collector hanger (Fig. 36, [3]) into the innermost slots (Fig. 36, [1]) of the profile rails until it clicks into place (Fig. 36, [2]).

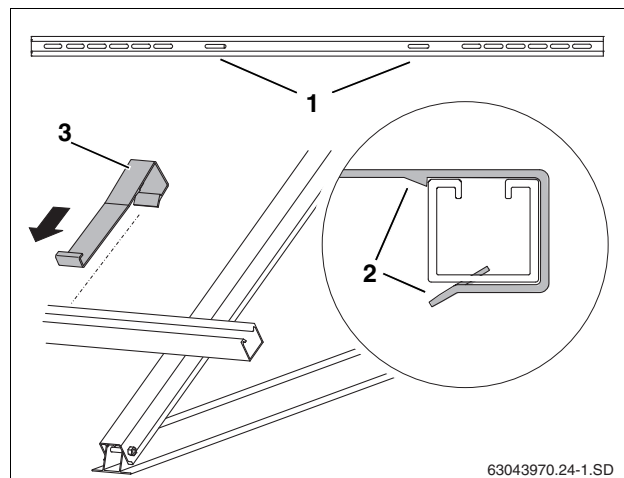

Fig. 36 Attaching collector hanger

- 1 Slots for hanger
- 2 Snap the hanger in place
- 3 Collector hanger

## 6 Collector installation

Observe the following safety and user instructions when commencing the collector installation.



**WARNING!**

### RISK TO LIFE

from a fall or falling parts.

- ▶ Take appropriate safety measures to prevent accidents when working on roofs.
- ▶ While working on the roof, take all necessary precautions against a possible fall.
- ▶ Always wear protective clothing and safety equipment.
- ▶ After completing an installation always verify that all components are installed according to the instructions and are securely attached.



**CAUTION!**

### RISK OF INJURY

during interruption of work.

- ▶ Secure the collectors and racks from falling.
- ▶ Stabilise the collector array.



**CAUTION!**

### SYSTEM DAMAGE

from damaged gaskets and contamination.

- ▶ Do not remove the rubber caps on the collector connections until immediately prior to installation.



### NOTICE

Use lifting equipment used by roofing contractors, sufficiently strong 3-point suction handles or special carrying handles (available as accessories) for easier lifting.



### NOTICE

Unsecured collectors may fall during handling and installation.

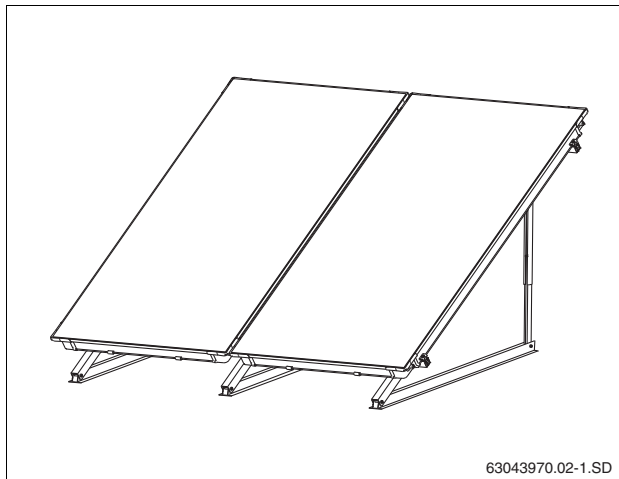

Fig. 37 Flat roof installation: 2 collectors

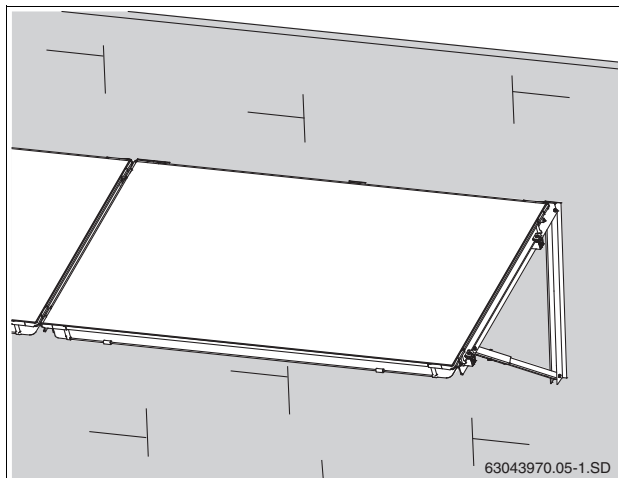

Fig. 38 Wall installation

## 6.1 Preparing to install the collectors

Before beginning actual installation on the flat roof or wall, preassemble the short solar hoses and dummy plugs on the ground to make work on the roof easier.

To secure the solar hoses, the hose clamp must be equipped with the locking ring.



**CAUTION!**

### SYSTEM DAMAGE

from leaks in the solar hoses.

- ▶ The hose clamp (Fig. 39, [2]) must be positioned correctly before pulling the handle (Fig. 39, [1]). Subsequent loosening requires using pliers and may cause a leak.



**CAUTION!**

### RISK OF INJURY

Don't pull the locking ring unless the hose clamp has been positioned at its final location.

### 6.1.1 Reverse-return piping

Collectors are piped in reverse-return. This ensures that each collector receives the same volume rate of flow (Fig. 40).



### NOTICE

The supply line can be fitted to the top right (Fig. 40) or left (Fig. 41). In this manual, the supply pipe is shown on the right.

The collectors must be installed inwith the collector sensor well (Fig. 41, [1]) at the top.



### NOTICE

If an automatic air-vent valve (accessory) will be installed at the highest point of the system, pitch the supply and return pipes toward the top.

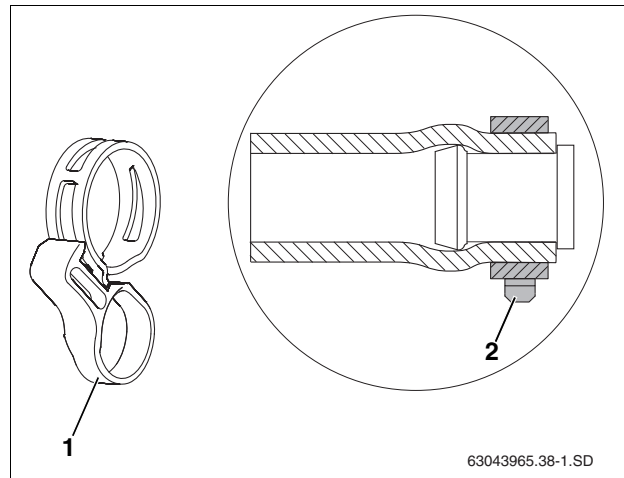

Fig. 39 Hose clamp with locking ring

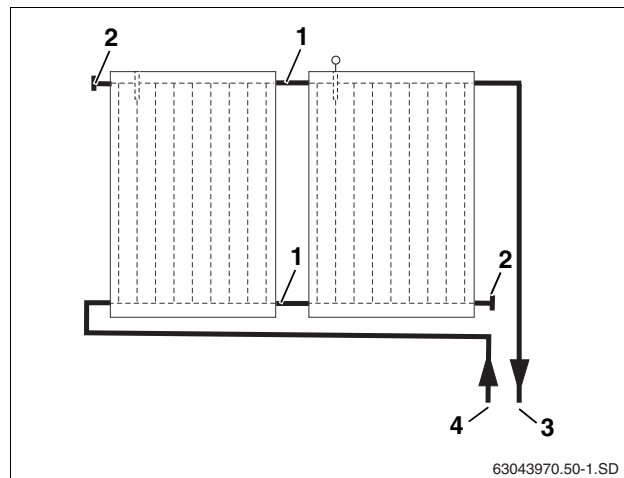

Fig. 40 Water connection – supply pipe (right)

- 1 Solar hose 4 in (95 mm)
- 2 2" (55 mm) solar hose and dummy plug
- 3 Supply pipe
- 4 Return line

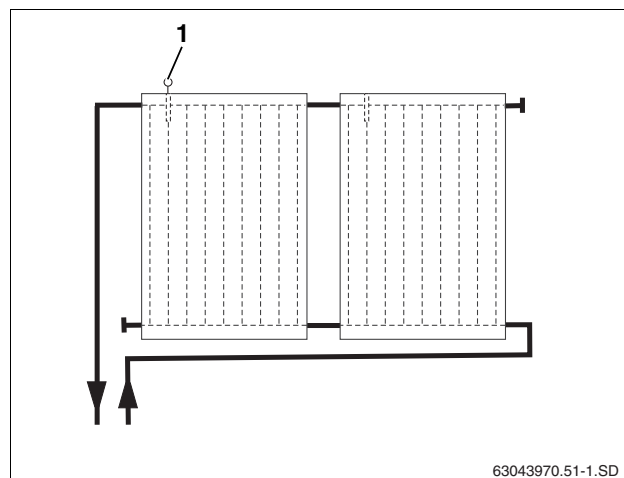

Fig. 41 Water connection – supply line (left)

### 6.1.2 Preassembling the connection set

The water connection between two collectors is made using the connection set (solar hoses 4" (95 mm) and hose clamps in the protective corners).



#### NOTICE

To make installation easier, we recommend that you place the solar hoses in hot water, especially when the ambient temperature is low.



#### NOTICE

The illustrations show the connection set with the first collector to be installed on the right.

- ▶ Remove plastic caps (transport protection) from the relevant collector connections.
- ▶ Push 4" (95 mm) solar hoses (Fig. 42, [2]) onto the right-hand connections on the second and any subsequent collector.
- ▶ Push the hose clamp (Fig. 42, [1]) over the solar hose (a second clamp will enable the other collector to be connected later).
- ▶ Once the hose clamp is sitting correctly, pull the locking ring to secure the connection (Fig. 42, [3]).

### 6.1.3 Dummy plug installation

Not all the connections are needed when connecting a collector array, so those that are not used must be plugged.

- ▶ Remove plastic caps (transport protection) from the relevant collector connections.
- ▶ Install a preassembled dummy plug into a 2" (55 mm) solar hose (Fig. 43, [2]) and mount on the two free connections on the collector array.
- ▶ Once the hose clamps are sitting correctly, pull the locking rings to secure the connection.

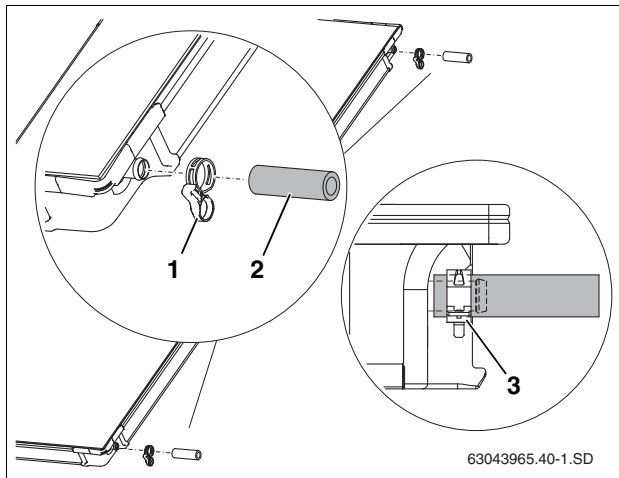

Fig. 42 Pre-assembling the connection on the second collector

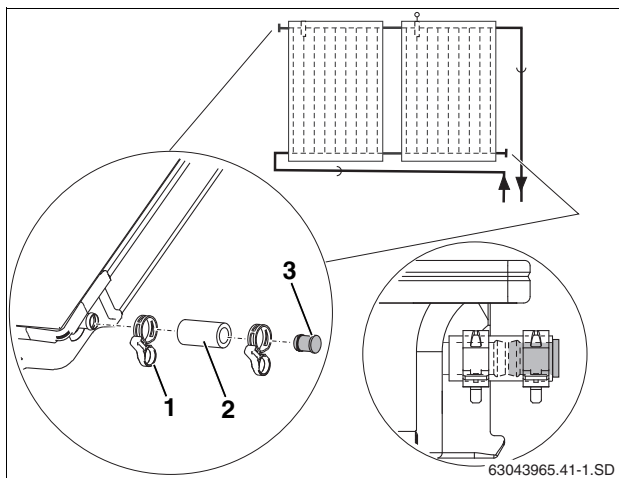

Fig. 43 Fitting the dummy plug and hose clamp

- 1 Hose clamp
- 2 2" (55 mm) solar hose
- 3 Dummy plug

## 6.2 Attaching the collectors



### NOTICE

At this stage it is advisable to check the complete rack with a level to be square and plumb. Verify that all screws and bolts are tight.

The collectors are attached to the profile rails using the single-sided collector clamps (Fig. 44, [2]) at the beginning and end of a collector array, and double-sided clamps (Fig. 44, [1]) between each collector.

In addition, the collector hangers (Fig. 44, [3]) hold the weight of the collectors.



### NOTICE

The plastic parts of the collector clamps do not have any support function. They are simply intended to make installation easier.

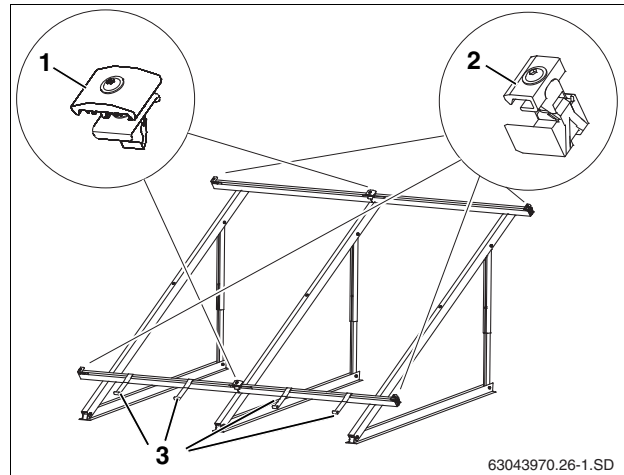

Fig. 44 Fasteners for the collector

### Fitting the single-sided collector clamp on the right

- Push single-sided collector clamps (Fig. 45, [1]) into the profile rails at the right-hand end of the collector array until they click into place in the first slotted hole on the profile rails.



### NOTICE

Do not install single-sided collector clamps on the opposite side of the collector array until the last collector has been installed.

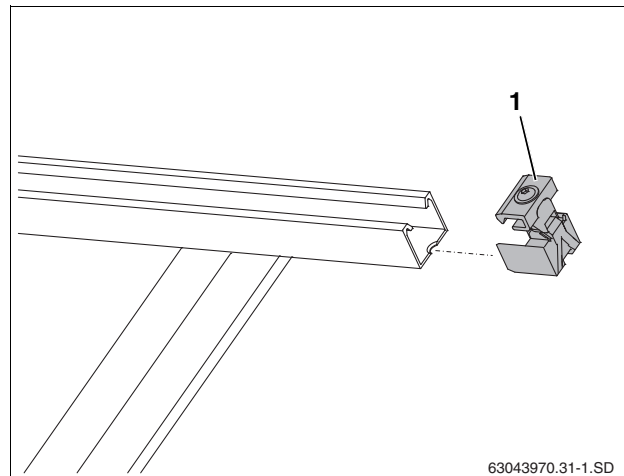

Fig. 45 Fitting the single-sided collector clamp

### Laying the first collector in place

Lay the collector down on the profile rails in such a way that the sensor well to receive the collector sensor is at the top. Begin by laying the collectors on the right-hand side of the profile rails.



**CAUTION!**

#### RISK OF INJURY

It takes at least two people to install the collectors.

- ▶ Place the first collector onto the profile rails and allow it to slide into the collector hangers (Fig. 46, [2]) (Fig. 46).

The lower collector edge must lie evenly in the opening of both collector hangers (Fig. 46, [1]).

- ▶ Carefully push collector (Fig. 47, [1]) up against the single-sided collector clamp and align horizontally.
- ▶ Verify that the collector sits square on the rack and that both collector hangers and both collector clamps grip the edges of the collector.
- ▶ Tighten single-sided collector clamp using size 5 Allen wrench (Fig. 47, [2]).



#### NOTICE

When the screw is tightened, the plastic guide breaks away at the pre-determined cut-off points.

The top (Fig. 47, [2]) of the collector clamp now grips the lower edge of the collector.

### Inserting a double-sided collector clamp

- ▶ Insert the double-sided collector clamp, nut first, into the opening made by the profile rail and connector so that the plastic spacer (Fig. 48, [1]) covers the profile rail.
- ▶ Push double-sided collector clamp up against the collector frame.



#### NOTICE

Do not tighten the screw until the second collector has been pushed up against the double-sided collector clamp.

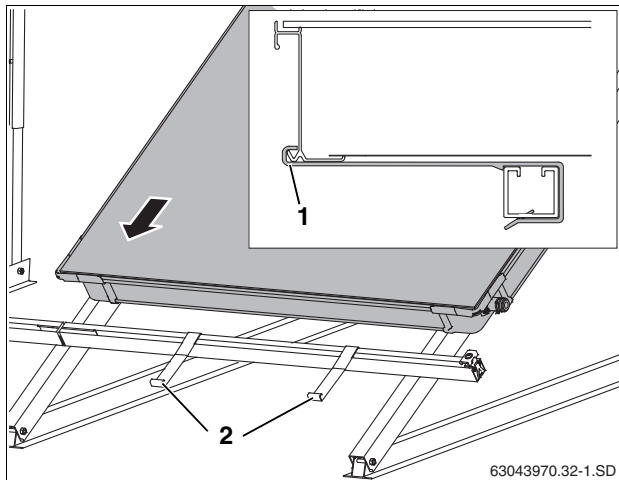

Fig. 46 Laying the first collector on the profile rails

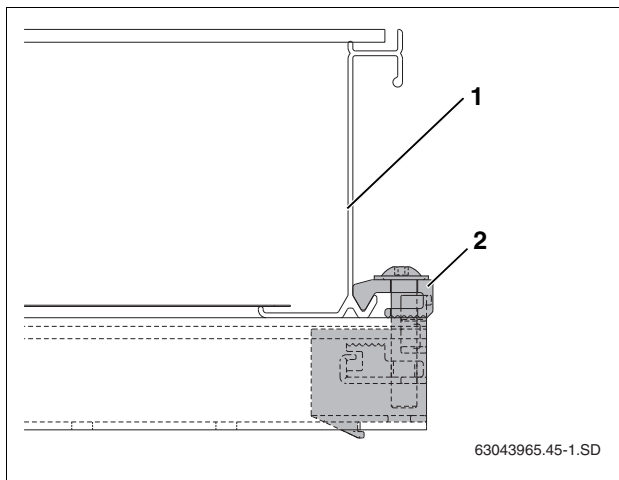

Fig. 47 Single-sided collector clamp screwed in place

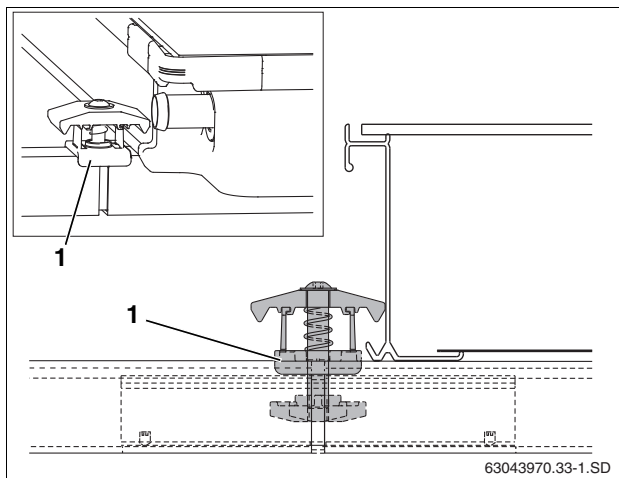

Fig. 48 Fitting a double-sided collector clamp

### Putting the second collector in place

- ▶ Lay the second collector along with the preassembled solar hoses (Fig. 49, [1]) onto the profile rails and let it slide into the collector hangers.
- ▶ Push the second hose clamp (Fig. 49, [3]) onto the solar hose.
- ▶ Push the second collector toward the first collector (Fig. 49, [2]) so that the preassembled solar hoses are pushed onto the connections of the first collector.

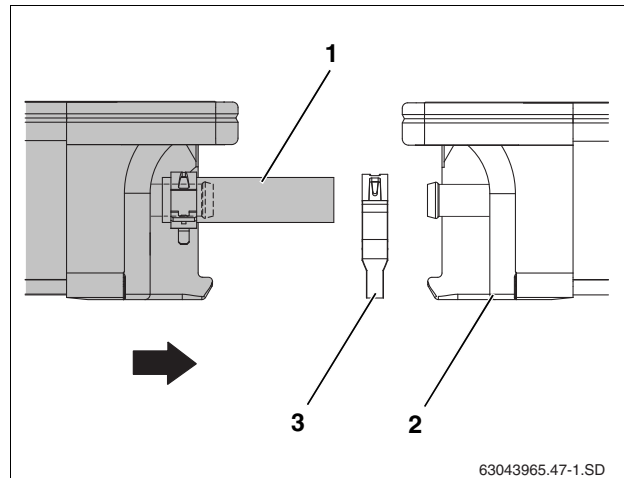

Fig. 49 Pushing second collector toward the first

- ▶ Push the hose clamp over the bead on the collector connection and pull the locking ring.



CAUTION!

### SYSTEM DAMAGE

from unsecured solar hoses and dummy plug.

- ▶ Secure every solar hose to the collector connection using a hose clamp (Fig. 50).

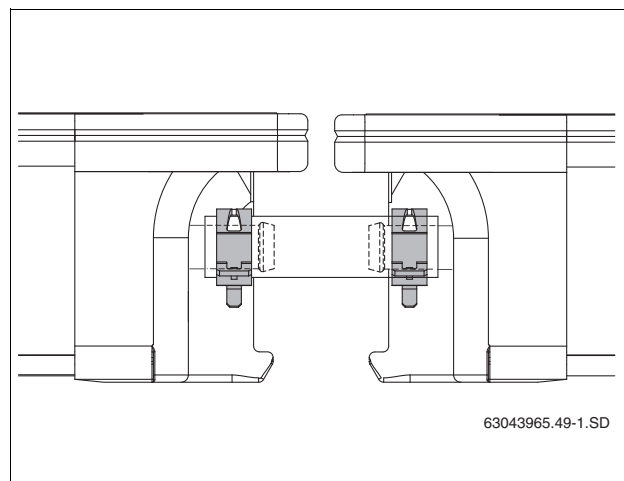

Fig. 50 Solar hose with secured hose clamps

- ▶ Tighten the screw on the double-sided collector clamp using the size 5 Allen wrench.



### NOTICE

When the screw is tightened, the plastic guides points break away at the pre-determined cutoff points.

The top (Fig. 51, [1]) of the collector clamp now grips the lower edge of both collectors.

Repeat the procedure for all other profile rails installed, and all other collectors.

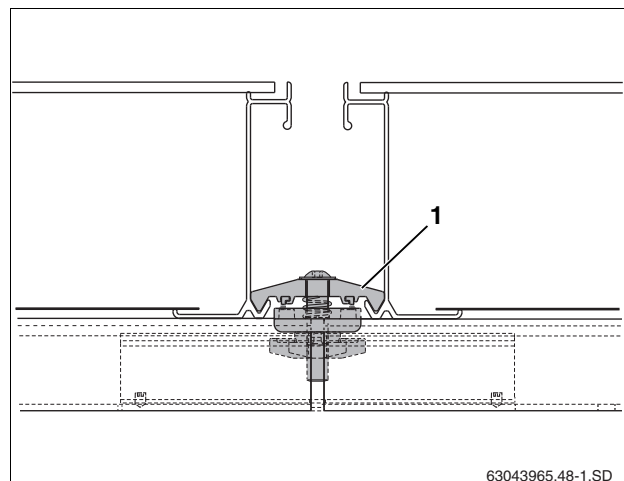

Fig. 51 Double-sided collector clamp between two collectors

### Fitting the single-sided collector clamp on the opposite end

Once all collectors are installed, the two remaining single-sided collector clamps can be attached.

- ▶ Push the single-sided collector clamp (Fig. 52, [1]) into the profile rails.
- ▶ Push collector clamp up against the collector frame and tighten using size 5 Allen wrench (Fig. 52, [2]).

The top (Fig. 52, [2]) of the collector clamp now grips the lower edge of the collector.



#### NOTICE

When the screw is tightened, the plastic guide breaks away at the pre-determined cut-off points.

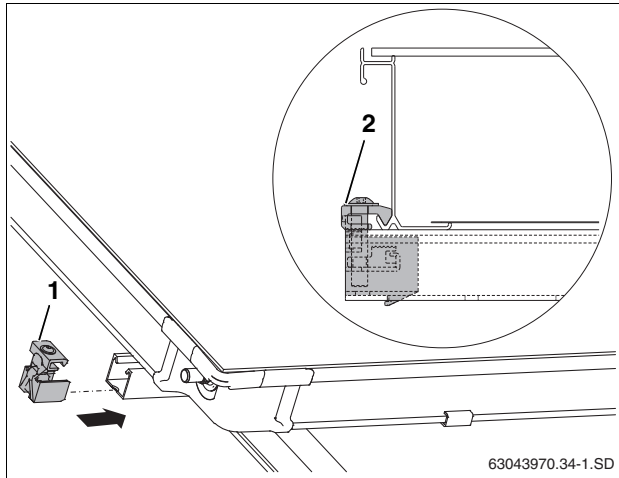

Fig. 52 Single-sided collector clamp (left)

## 7 Collector sensor connection



### NOTICE

The collector sensor is part of the pump station or the solar controller.

Ensure the correct sensor placement in single and multi-array solar systems (Fig. 53).



CAUTION!

### SYSTEM DAMAGE

from faulty sensor cable.

- ▶ Protect the cable from possible damage from the weather, rodents, and birds.

### Insertion point

The collector sensor must be installed in the collector that the supply pipe is connected to (Fig. 53, [2]).

- Location (Fig. 53, [A]) for single array collector systems.
- Location (Fig. 53, [B]) for dual array collector systems.



### NOTICE

Always install the sensor where the hottest fluid temperature of the array is to be expected, or where the supply pipe run connects to the pump station.

### Installing the collector sensor

For a continuously troublefree reading of the absorber temperature, the collector sensor (Fig. 54, [1]) must be completely inserted into the sensor well as far as it will go (approx. 10 inches (250 mm)).

- ▶ Using the collector sensor or screwdriver, puncture the membrane of the sensor well (Fig. 54, [3]).
- ▶ Screw strain relief (Fig. 54, [2]) into sensor bushing.
- ▶ Insert collector sensor approx. 10 inches (250 mm) into the sensor well (as far as it will go).
- ▶ Tighten the strain relief (Fig. 54, [2]), to secure the sensor in place.
- ▶ Use cable ties or similar to route the sensor cable securely until it meets up with the twin tube.

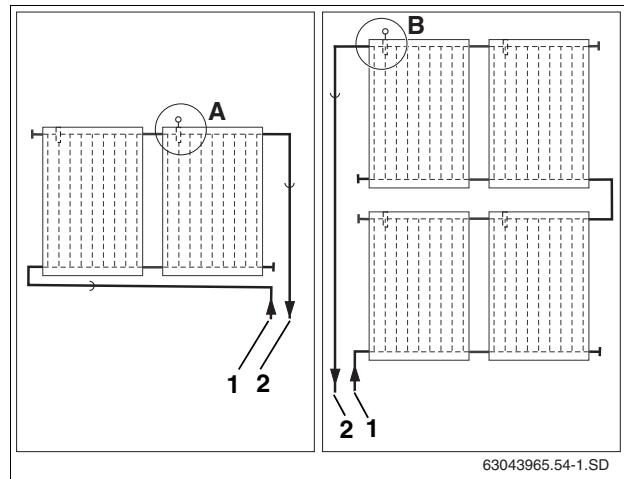

Fig. 53 Collector sensor well location (schematic)

- 1 Return line
- 2 Supply pipe

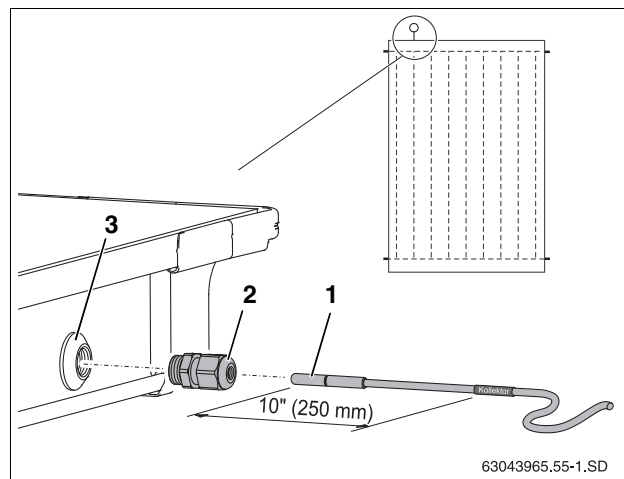

Fig. 54 Inserting the collector sensor into the collector

- 1 Collector sensor
- 2 Strain relief
- 3 Sensor well

**NOTICE**

If the membrane (Fig. 54, [3]) on the wrong collector was accidentally punctured, it can be resealed using the plug from the connection kit. First remove the nut in the sensor well using the strain relief (Fig. 54, [2]).

## 8 Hydraulic connection

Information on routing the pipes can be found in the pump station installation instructions.



**CAUTION!**

### SYSTEM DAMAGE

from leaks in the collector connection, due to movements caused by expansion and contraction of the pipework.

- ▶ Route the supply pipe (Fig. 55, [1]) alongside the collector, rather than vertically downward.

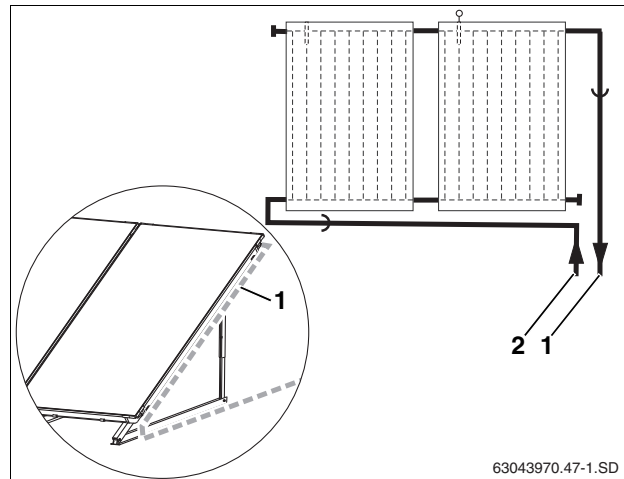

Fig. 55 Feeding header pipes to the collector array

- 1 Supply pipe
- 2 Return line

### 8.1 Pipe bracket

When routing the supply pipe alongside the collector, use the supplied bracket to attach it securely.



### NOTICE

We recommend commercially available hose clamps (Fig. 56, [1]) attached to the M8 thread on the bracket (Fig. 56, [2]).

Select a hose clamp according to the outside diameter of the supply pipe, incl. insulation.

- ▶ Place bracket (Fig. 56, [3]) onto collector frame and tighten with size 5 Allen wrench.
- ▶ Install supply pipe in the hose clamp.

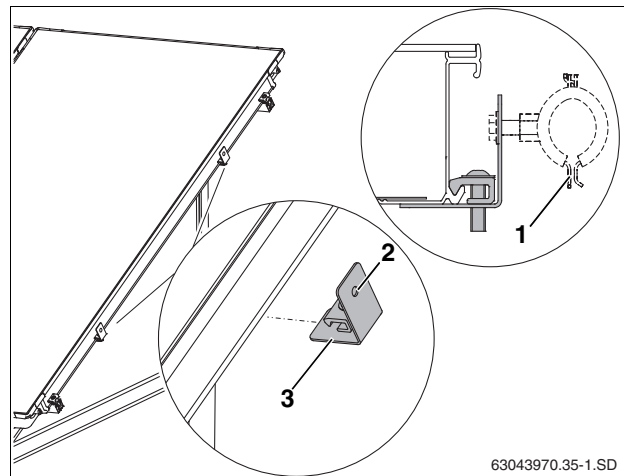

Fig. 56 Fastening holder to the collector frame

- 1 Hose clamp (not supplied)
- 2 M8 thread
- 3 Bracket

## 8.2 Hydraulic collector connection without an air vent

If filling a solar system using a high volume and high pressure filling station, an air vent on the roof is not required unless corrugated piping is used for large portions of the pipework.

Follow these steps to make the connection:

- ▶ Remove plastic caps (transport protection) from the relevant collector connections.
- ▶ Push the nut (Fig. 57, [1]) over the collector connection.
- ▶ Open the washer (Fig. 57, [2]) slightly without separating the two pieces, slide over the collector connection and press together.
- ▶ Align the elbow (Fig. 57, [3]) with the nut and washer and tighten.
- ▶ Align the elbow (Fig. 57, [3]) with the nut and washer and tighten.

Perform the same procedure with the return connection.

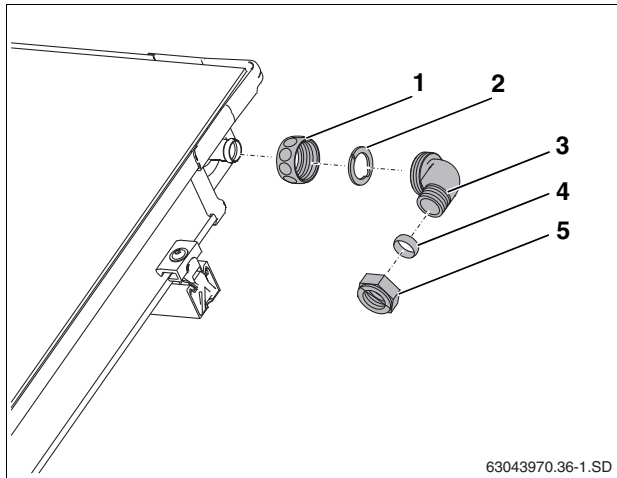

Fig. 57 Fitting supply pipe (with no vent on roof)

- 1 Nut
- 2 Washer
- 3 Elbow
- 4 Compression ring 1/2"
- 5 Compression nut

## 8.3 Hydraulic collector connection with an air vent (accessory)

If a high volume and high pressure filling station is not available for filling, if corrugated pipe is used for large portions of the pipe runs, or if the pipes are routed in a way that may prevent air from being bled easily, install an air vent (Fig. 58, [2]) and route all pipes sloped toward the collector array (Fig. 58).

Avoid frequent changes in direction.



### NOTICE

For each change of direction downward and each new rise, an additional air vent may be necessary.

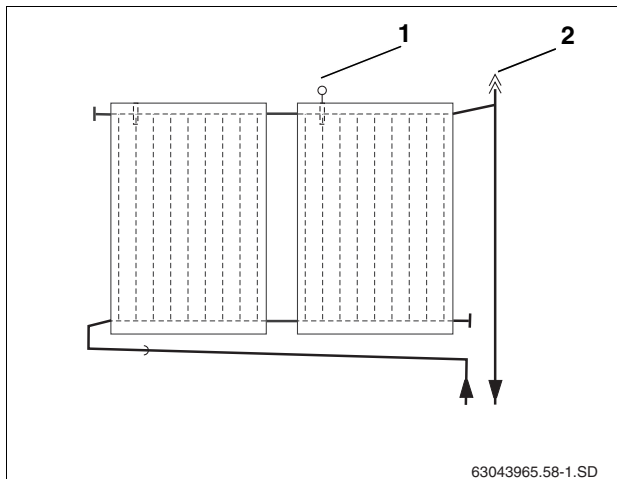

Fig. 58 Air vent with pipes sloped upward

- 1 Collector sensor
- 2 Automatic air-vent above the collector supply pipe

**NOTICE**

Ensure the air vent is rated for Propylene Glycol and the temperatures of the solar thermal system.

**Functionality of the automatic air-vent valve**

The solar thermal system is vented through the opened bleeder screw. When in operation, the weather protection cap (Fig. 59, [1]) must always be positioned over the bleeder screw to prevent dirt from entering the system.

Open the air-vent by unscrewing the bleeder screw one full turn.

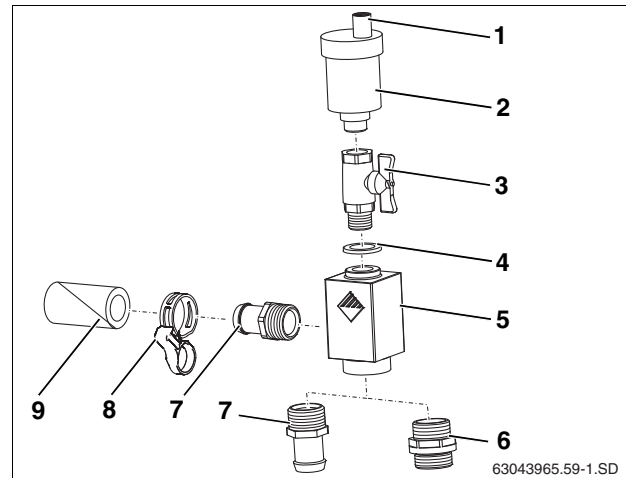

Fig. 59 Universal air vent set

1	Weather protection cap (bleeder screw)	1 x
2	Automatic air vent	1 x
3	Ball valve	1 x
4	Gasket	1 x
5	Vent body	1 x
6	Double nipple with O-ring	1 x
7	Hose connector with O-ring	1 x
8	Hose clamp	1 x
9	Solar hose 2 " (55mm)	1 x

**Installing the air-vent**

- ▶ Push short solar hose (55 mm, Fig. 60, [1]) onto the supply connection on the collector and secure using the hose clamp.
- ▶ Firmly screw hose fitting R $\frac{3}{4}$  with O-ring (Fig. 60, [3]) into the air vent body (Fig. 60, [4]) and tighten.
- ▶ Slide a hose clamp (Fig. 60, [2]) over the hose. Push the hose over the hose fitting (Fig. 60, [3]) until it reaches the stop and pull the locking ring to secure it in place.
- ▶ Screw double nipple with O-ring into air vent body (Fig. 60, [5]).
- ▶ Connect the supply pipe to the compression fitting (Fig. 60, [6]).

**NOTICE**

Ensure the air vent is positioned vertically otherwise the float will not work properly.

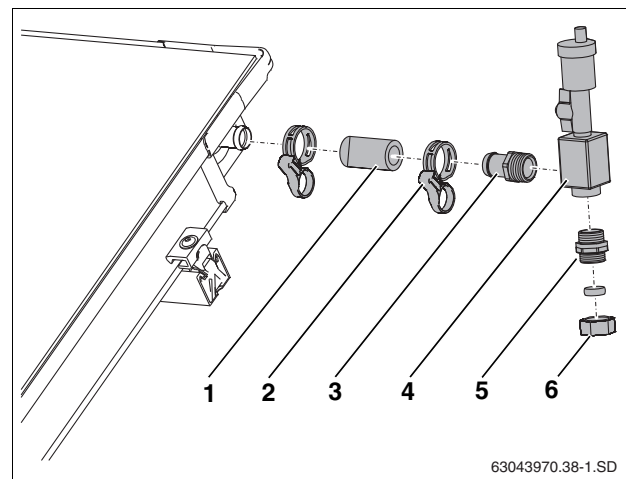

Fig. 60 Connecting the air-vent valve on roof

1	Solar hose 2 " (55mm)
2	Hose clamp
3	Hose connector R $\frac{3}{4}$ with O-ring
4	Air vent body
5	Double nipple with O-ring
6	1/2" Compression fitting

## 8.4 Connecting two arrays

Use a second connection kit for connecting two collector arrays (Fig. 61, [1]).

- ▶ Install individual parts as described in Section 8.2 "Hydraulic collector connection without an air vent".
- ▶ Make on-site connection between collector array.

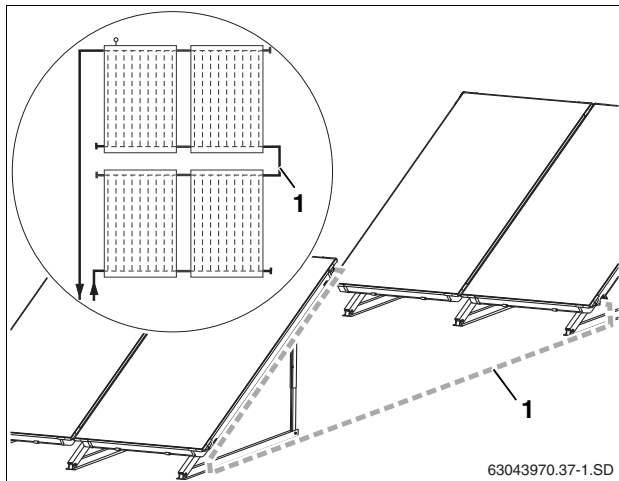

Fig. 61 Two collector arrays, one behind the other

## 9 Final activities

### 9.1 Checking the installation



#### NOTICE

Do not insulate any pipes before a thorough leak test has been performed.

#### Checks

1	Solar hoses secured with hose clamps (locking ring pulled)?	<input type="checkbox"/>
2	Screws on the collector clamp (single-sided and double-sided) tight?	<input type="checkbox"/>
3	All collector triangles connected to profile rails?	<input type="checkbox"/>
4	Collector hangers installed and snapped in place in profile rails?	<input type="checkbox"/>
5	Sensor inserted as far as it will go and secured with strain relief?	<input type="checkbox"/>
6	Pressure test carried out and all connections leak tested (see pump station instructions)?	<input type="checkbox"/>



#### NOTICE

If an automatic air-vent valve (accessory) is installed, the ball valve must be closed after the venting procedure (see pump station installation instructions) has been completed.

In larger systems and where corrugated pipes are being used, it may be necessary to bleed the remaining air after 1-2 weeks of operation.

### 9.2 Insulating the pipes

- For the insulation of external pipework, use only UV and high temperature resistant materials.
- For the insulation of internal pipework, use only high temperature resistant materials.
- Ensure the insulation is weather, rodent and bird proof.

## 10 Quick reference guide for mounting and pressure filling

These instructions are only intended as an overview of the work to be carried out. You **MUST** follow the detailed descriptions for the work on the pages mentioned, and obey all safety and user instructions.

### Fitting triangles and profile rails

1. Insert telescopic rails into each other according to the selected inclination, and secure. page 13
2. Drill holes in I-beams (or similar), and secure collector triangles with screws. page 23
3. Connect profile rails together using connectors. page 25
4. Attach profile rails to collector triangles. page 27
5. Align sides of the profile rails symmetrically. page 27
6. Install collector hangers on the two inner slots on the lower profile rails. page 27

### Preparing to install the collectors

7. Install solar hoses 4" (95 mm) on the right-hand side of the second and all remaining collectors. page 31
8. Push preassembled dummy plugs onto those connections that are not needed and secure using hose clamps. page 31

### Fastening the collectors

9. Push single-sided collector clamp (right) into profile rails. page 31
10. Place first collector (right) onto profile rails and push onto collector clamp. page 30
11. Tighten collector clamp on the right. page 31
12. Place double-sided collector clamp into profile rail and push onto first collector. page 31
13. Push second collector with pre-assembled solar hoses toward the first collector and secure using hose clamps. page 33
14. Tighten screws on the double-sided collector clamp. page 33
15. Repeat the procedure for all other collectors. page 33
16. Fit single-sided collector clamps on the left page 34

### Piping connection

17. Insert collector sensor as far as it will go into the collector that will be connected to the supply pipe, and secure. page 35
18. Install bracket for supply pipe on collector frame and tighten. page 37
19. Attach elbow to supply and return pipes. page 38
20. Attach supply and return pipes to the elbows. page 38
21. Perform installation checks. page 41
22. Insulate supply and return pipes with UV and high temperature resistant material. page 41

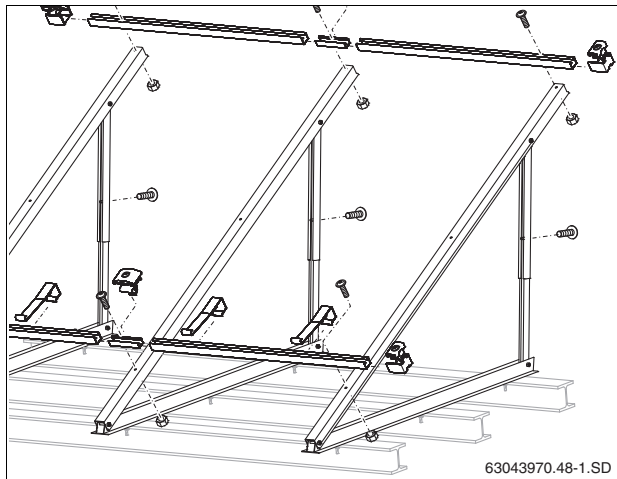

Fig. 62 Installing on a flat roof

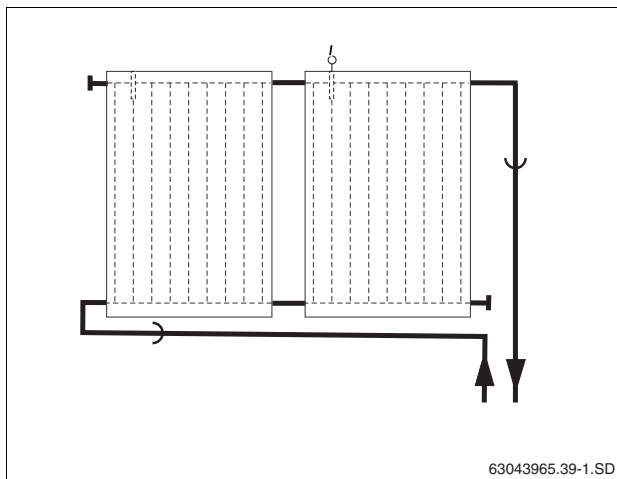

Fig. 63 Water connections

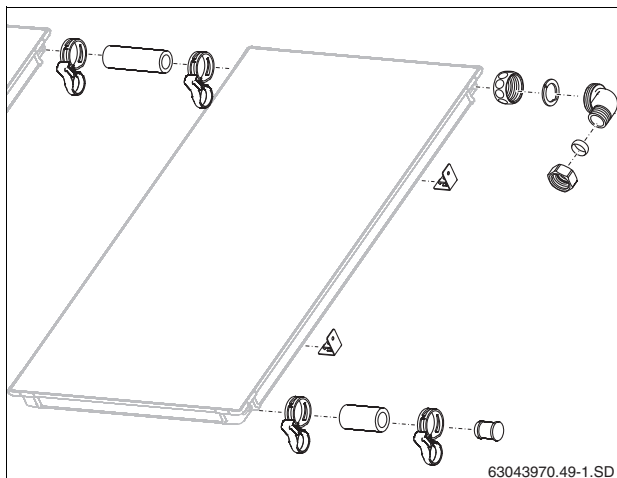
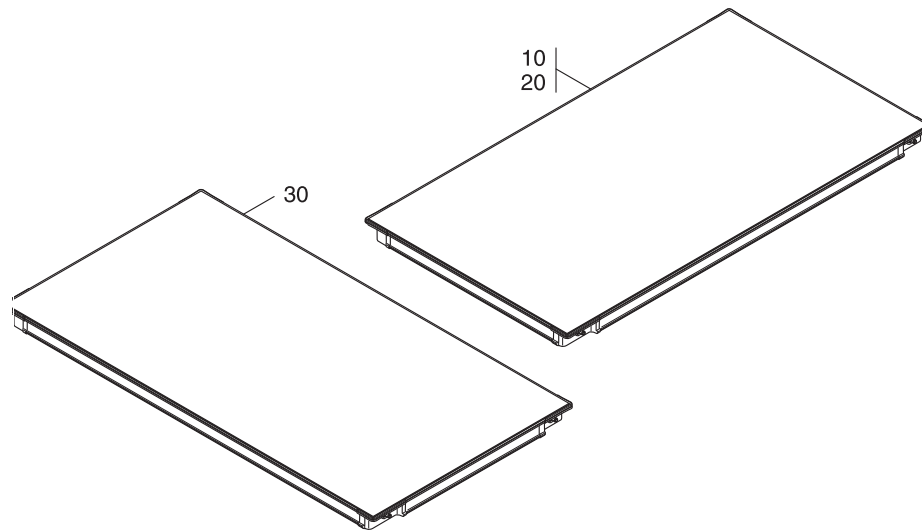

Fig. 64 Fitting the collector sensor and connection parts

**BOSCH**

**FKC-1S V2**  
**7 747 025 774**

Reg.-Nr.: 011-7S050 F

**315 FD 002 000261**

Dimensions: 2070x1145x90mm  
 Year of production: 2010  
 Made in Germany

$A_G$ : 2.37 m<sup>2</sup>/2.83yd<sup>2</sup>  
 $p_{max}$ : 6 bar/87 psi  
 $P_{pr}$ : 9 bar/131 psi  
 $t_{stg}$ : 188°C/370°F  
 $V_f$ : 0.86 l/0.227 gal  
 $m$ : 41 kg/91 pound  
 Fluid: H<sub>2</sub>O/PP-Glycol  
 50/50 & 70/30

**BOSCH**

**FKC-1W V2**  
**7 747 025 775**

Reg.-Nr.: 011-7S050 F

**315 FD 002 000227**

Dimensions: 2070x1145x90mm  
 Year of production: 2010  
 Made in Germany

$A_G$ : 2.37 m<sup>2</sup>/2.83yd<sup>2</sup>  
 $p_{max}$ : 6 bar/87 psi  
 $P_{pr}$ : 9 bar/131 psi  
 $t_{stg}$ : 188°C/370°F  
 $V_f$ : 1.25 l/0.330 gal  
 $m$ : 42 kg/93 pound  
 Fluid: H<sub>2</sub>O/PP-Glycol  
 50/50 & 70/30

Item	Part Number	Description	Weight in lb
20	7747021978	FKC-1s Solar Flate Plate Collector Portrait	93 1/2
30	7747021980	FKC-1w Solar Flate Plate Collector Landscape	95 1/2

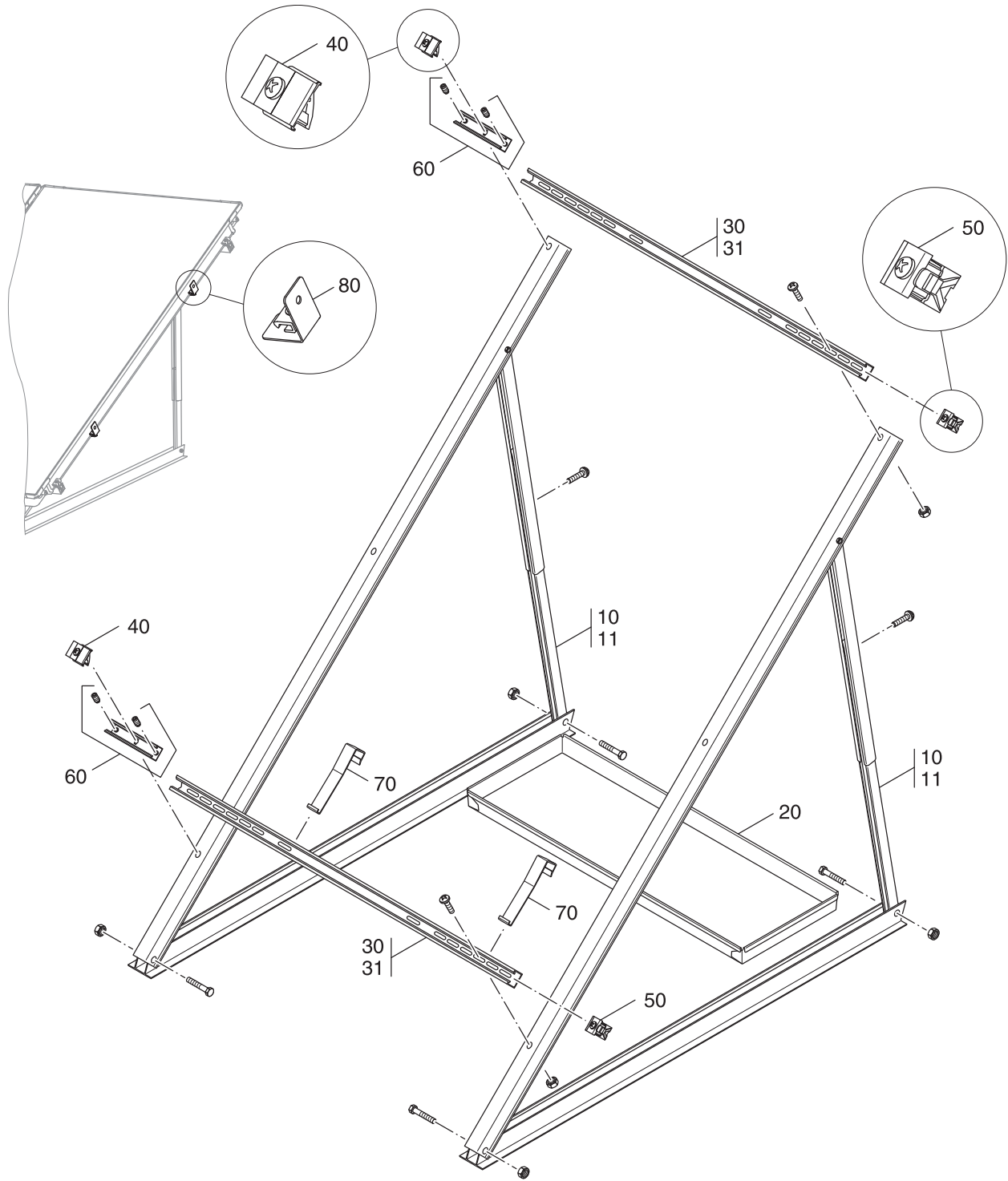

67910059-00-Flat Roof Installation - Horizontal/Vertical, Facade Horizontal

Item	Part Number	Description	Weight in lb
10	83077590	Telescopic Rail for Flat Roof Installation	14.5
20	63045309	Ballast Tray for Flat Roof Installation	6.7
30	63045239	Profile Rail - Cross Support - Portrait	2.95
31	63045240	Profile Rail - Cross Support - Landscape	5.5
40	63045244	Double-sided Collector Clamp	2.5
50	63045246	Single-sided Collector Clamp	0.2
60	63045241	Profile connector with threaded studs	0.24
70	63045243	Collector hanger	0.2
80	63046150	Bracket for supply pipe	0.24



Item	Part Number	Description	Weight in lb
10	63046151	Elbow G3/4 kpl	0.4
		Available Parts:	
90	63045250	Hose Clip 1/2" Set 5 Each	0.05
70	63045310	O-Ring 21x3,0 Shore70 Set 5 Each	0.01
15	63046195	Connection Assembly FKC/SKN	0.1
		Includes:	
120	(x)	Union nut G1 D25x17Ms	
100	(x)	Washer G1x21	
20	63045247	Hose clamps Set 5 Each	0.2
30	x	Solar Hose 3/4x4" (95mm)	
40	63045248	Dummy plug	0.16
80	85336132	Solar Hose 3/4"x40" (1000 mm)	1.54
110	63045249	Hose connector Assembly G3/4xD21 kpl	0.2
		Available Parts:	
50	63045301	O-Ring 25x3,0 Shore70 Set 5 Each	0.02
90	63045250	Compression Ring 1/2" Set 5 Each	0.05
60	63045253	Elbow G1xD21 Ms kpl	0.27
		Available Parts:	
70	63045310	O-Ring 21x3,0 Shore70 Set 5 Each	0.01
15	63045306	Union Assembly FKC/SKN	*
		Available Parts:	
120	(x)	Union Nut G1 D25x17Ms	
100	(x)	Washer G1xD21	

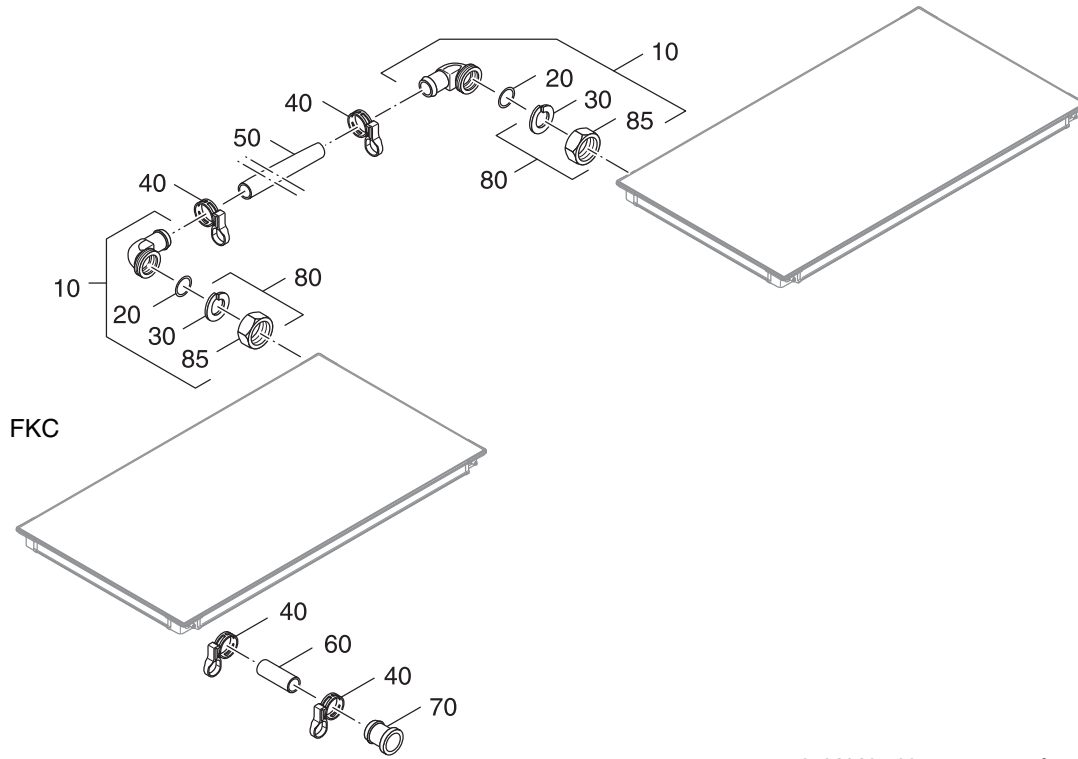

67910167-00-row connection sets FKC, SKN

Item	Part Number	Description	Weight in lb
Collector Row Connection Kits FKC/SKN			
10	63045253	Elbow Compression Fitting G1xD21 Ms kpl	2.5
Available Parts:			
20	63045310	O-Ring 21x3,0 Shore70 Set 5 Each	0.01
80	63045306	Connection Set, Row FKC/SKN	*
Includes:			
30	x	Locking Washer G1x21	
85	x	Nut G1 D25x17Ms	
40	63045247	Hose clamp Set 5 Each	0.19
50	85336132	Solar Hose 3/4"x40" (1000 mm)	1.54
60	x	Solar Hose 3/4x4" (95mm)	
70	63045248	Dummy Plug D21	0.14

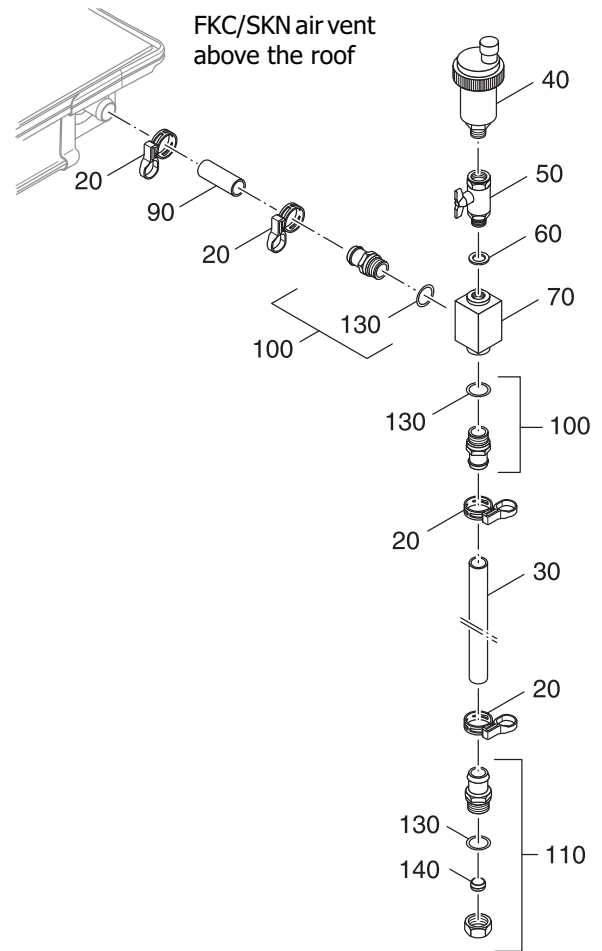
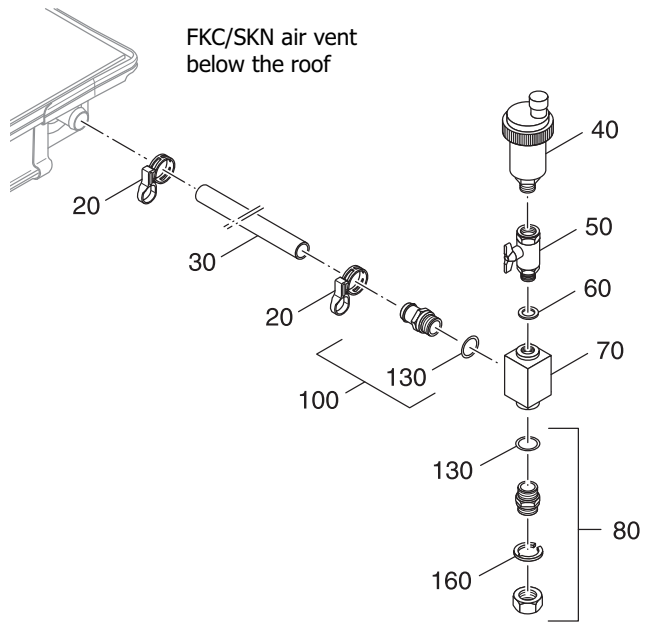

67910064-00-Air vent valve set FKC, SKN

Item	Part Number	Description	Weight in lb
20	63045247	Hose clamp Set 5 Each	0.19
30	85336132	Solar Hose 3/4"x40" (1000 mm)	1.54
40	63015362	Automatic Air Vent R3/8 Solar	0.86
50	85103282	Ball Valve 3/8"	0.55
60	63012692	Gasket D17x24x2 AFM34 (5x)	0.04
70	63045299	Air vent body	0.88
80	63045252	Double Nipple 18 Clamp G3/4 kpl	0.17
Available Parts:			
130	63045301	O-Ring 25x3,0 Shore70 Set 5 Each	0.02
160	63020599	Locking Washer, Stainless DN16x1,5 Set 10 Each	0.033
90	85336132	Solar Hose 3/4"x40" (1000 mm)	1.54
100	63045249	Hose connector 18 ClampG3/4xD21 kpl Compression Ring and Nut are not required	0.2
Available Parts:			
130	63045301	O-Ring 25x3,0 Shore70 Set 5 Each	0.02
110	63045249	Hose connector 18 ClampG3/4xD21 kpl	0.2
Available Parts:			
130	63045301	O-Ring 25x3,0 Shore70 Set 5 Each	0.02
140	63045250	Compression Ring 5/8" (18mm) Set 5 Each	0.05







**United States and Canada**

Bosch Thermotechnology Corporation  
50 Wentworth Avenue  
Londonderry, NH 03053  
Tel. 603-552-1100  
Fax 603-584-1681  
[www.boschsolar.com](http://www.boschsolar.com)

Products manufactured by  
Bosch Thermotechnik GmbH  
Junkersstrasse 20-24  
D-73249 Wernau  
[www.bosch-thermotechnology.com](http://www.bosch-thermotechnology.com)

Bosch Thermotechnology Corp. reserves the right  
to make changes without notice due to continuing  
engineering and technological advances.