



Installation and Service Instructions for Contractors

Residential Gas Condensing Boiler

Greenstar

ZBR 21-3A | ZBR 28-3A | ZBR 35-3A | ZBR 42-3A | ZWB 28-3A | ZWB 35-3A |
ZWB 42-3A



0010004900-002

WARNING:

Improper installation, set-up, modification, operation or maintenance of the heating system can cause personal injury and property damage. Follow these instructions precisely.

If you require assistance or further information, contact a trained and certified installer or the gas supply company.

WARNING:

The operating instructions are part of the technical documents that must be handed over to the owner or operator of the heating system. Explain to the owner or operator how to use the heating system using the operating instructions. Make sure that they are familiar with all required information for the safe and proper operation of the heating system.

These instructions are available in English and French.

Please keep these instructions for future reference.

6721853955 (2024/05) US/CA



Contents

1	Explanation of symbols and safety instructions	3
1.1	Explanation of symbols	3
1.2	General safety instructions	4
2	Scope of delivery	5
2.1	ZBR...-3A - Residential boiler for space heating and loading of indirect fired DHW tanks	5
2.2	ZWB...-3A - Residential combi boiler for space heating and DHW generation	5
3	Product Description	6
3.1	Proper use	6
3.2	Overview of boiler types	6
3.3	Rating plate	6
3.4	Appliance description	6
3.5	Accessories	6
3.6	Product dimensions and minimum clearances	7
3.7	Appliance layout heating boiler ZBR...-3A	8
3.8	Appliance layout ZWB...-3A	10
3.9	Electrical wiring ZBR...-3A	12
3.10	Electrical wiring ZWB...-3A	14
3.11	Technical data ZBR...-3A	16
3.12	Technical data ZWB...-3A	19
3.13	Condensate composition	21
4	Regulations	22
4.1	Compliance with standards and regulations	22
4.2	Operating limits of the boiler	22
4.3	Additional regulations for installations in the Commonwealth of Massachusetts	23
5	Examples of Installations	24
5.1	Multiple zones using zone valves with DHW	24
5.2	Multiple zones using circulators	26
6	Notes on installation and operation	28
6.1	Notes on installation and operation	28
6.1.1	Important notes	28
6.1.2	Other important information	29
6.1.3	Water Supply Pressure	29
6.2	Comparing the size of the integrated expansion vessel	30
6.3	Selecting an external expansion vessel (ZBR...-3A)	30
6.4	Selecting the installation location	30
6.5	Pre-installing pipes	31
6.6	Mounting the appliance	32
6.7	Installing the low water cut off (LWCO)	33
6.8	Connecting flue gas accessories	34

6.8.1	Installation of the exhaust and air intake system	35
6.8.2	Examples of approved horizontal and vertical venting installation	39
6.8.3	Vent and combustion air pipe lengths	41
6.9	Testing gas and water connections for leaks	42
7	Electrical connection	43
7.1	General notes	43
7.2	Low voltage electrical connections in the Heatronic boiler control	43
7.2.1	Open the Heatronic boiler control	43
7.2.2	Connecting the BUS-system	43
7.2.3	Connecting the outdoor temperature sensor	44
7.2.4	Connecting the DHW tank temperature sensor (only ZBR...-3A)	44
7.2.5	Connecting additional accessories	45
7.3	Electrical connections in the junction box (120 VAC)	46
7.3.1	Mounting rails for junction box	46
7.3.2	Connecting an external heating zone pump or DHW recirculation pump	46
7.3.3	DHW tank loading pump or 3-way valve with spring return (only ZBR...-3A)	47
7.3.4	Connecting mains power supply	47
7.4	Connecting the LWCO device	48
8	Commissioning	49
8.1	Before operating the appliance	50
8.2	Switching the appliance ON/OFF	50
8.3	Heat setting	50
8.3.1	Switching on the heating	50
8.3.2	Optional - Activate Outdoor Reset	50
8.4	Programming the Bosch Room Controller	52
8.5	After commissioning	52
8.6	ZBR...-3A appliances (heating boilers) with DHW tank: Setting the DHW temperature	52
8.7	ZWB...-3A appliances (combi boilers): Setting the DHW temperature	53
8.8	Setting manual summer mode	53
8.9	Setting frost protection	53
8.10	Activating the key pad lock	53
9	ZBR...-3A appliances (heating boiler) with DHW tank: Thermal disinfection	54
10	Boiler circulator	54
10.1	Pump anti-seize protection	54
10.2	Changing the pump curve of the boiler pump	54

11	Heatronic boiler control settings	55
11.1	Guideline to service functions	55
11.2	Overview of the service functions	56
11.2.1	First service level (press and hold the service button until it lights up)	56
11.2.2	Heating curve	56
11.2.3	Second service level (at first service level, service button lights up, press ECO button and key pad lock button simultaneously until 8.A appears)	56
11.3	Description of the service functions	57
11.3.1	First service level	57
11.3.2	Second service level	61
12	Gas adjustment	62
12.1	Converting to a different gas type	62
12.2	Installation location higher than 2,000 feet (610 m) above sea level	62
12.3	Checking and setting the gas-air ratio (CO2 or O2), if required	62
12.4	Dynamic gas pressure test port	64
13	Flue gas test	64
13.1	Emissions test button	64
13.2	Measuring CO content of flue gas	64
14	Environmental protection and disposal	65
15	Inspection and maintenance	65
15.1	Description of various steps	66
15.1.1	Calling up the latest fault (service function 6.A)	66
15.1.2	Fresh water filter (only combi boiler ZWB...-3A)	66
15.1.3	Plate type heat exchanger (only combi boiler ZWB...-3A)	66
15.1.4	Checking electrodes	67
15.1.5	Burner servicing	68
15.1.6	Heat exchanger block inspection and cleaning	68
15.1.7	Cleaning condensate trap	70
15.1.8	Checking the mixer diaphragm	70
15.1.9	Checking the expansion vessel	70
15.1.10	Setting the boiler water pressure	70
15.1.11	Testing system water quality	70
15.1.12	Checking the electrical wiring	70
15.2	Maintenance and inspection checklist	71
16	Readings on the display	72

17	Faults	73
17.1	Troubleshooting	73
17.2	Faults that are shown on the display	74
17.3	Faults that are not shown on the display	76
17.4	Check sensor values	77
17.4.1	Outdoor temperature sensor	77
17.4.2	Additional supply temperature limiter	77
17.4.3	Supply temperature sensor, External supply temperature sensor, DHW tank temperature sensor, DHW temperature sensor	77
17.5	Replacement code plug	77

18	Commissioning log for the appliance	78
-----------	--	-----------

1 Explanation of symbols and safety instructions

1.1 Explanation of symbols

Warnings

In warnings, signal words at the beginning of a warning are used to indicate the type and seriousness of the ensuing risk if measures for minimizing danger are not taken.

The following keywords are defined and can be used in this document:

 **DANGER**
DANGER indicates that severe or life-threatening personal injury will occur.

 **WARNING**
WARNING indicates that severe to life-threatening personal injury may occur.

 **CAUTION**
CAUTION indicates a hazardous situation which, if not avoided, could result in minor to moderate injury.

NOTICE
NOTICE is used to address practices not related to personal injury.

Important Information

 The info symbol indicates important information where there is no risk to people or property.

Additional symbols

Symbol	Explanation
▶	Sequence of steps
→	Cross-reference to another part of the document
•	Listing/list entry
–	Listing/list entry (2nd level)

Table 1

1.2 General safety instructions

If you hear gas leaking!

- ▶ Leave the building immediately.
- ▶ Prevent others from entering the building.
- ▶ Notify the police and fire department from outside the building.
- ▶ From outside the building, call the gas supply company and a trained and certified installer or service company.

⚠ If you smell gas

- ▶ Turn off the gas shut-off valve.
- ▶ Open windows and doors.
- ▶ Do not touch any electrical switch, telephone, and do not use outlets.
- ▶ Extinguish all open flames.
- ▶ Do not smoke!
- ▶ Do not use lighters!
- ▶ Warn all occupants of the building, but do not ring any bell.
- ▶ From outside the building, call the gas supply company and a trained and certified installer or service company.

If you smell flue gas!

- ▶ Switch off the heating system by shutting off the emergency shut-off switch.
- ▶ Open windows and doors.
- ▶ Call a trained and certified installer or service company.

DANGER: Risk of fatal injury from failing to consider your own safety!

- ▶ Never risk your own life. Your own safety must always take the highest priority

NOTICE: Risk of appliance damage from improper operation of the boiler!

- ▶ Only use the boiler for its intended purpose.
- ▶ Only operate the boiler if it has been installed and maintained per the instructions provided in the Installation Manual.
- ▶ Do not attempt to operate an appliance if any part of it is not in working order or is damaged.
- ▶ Use only original spare parts! The use of parts not supplied by the manufacturer may cause damage to the boiler, other property and personal injury. Also, boiler damage caused by the use of unauthorized parts is not covered by the warranty.

DANGER: Risk of fire when soldering and brazing!

- ▶ Take appropriate protective measures when soldering and brazing around combustible and flammable material.

NOTICE:

- ▶ The installation must comply with all applicable national, state, and local codes, rules, and regulations.
- ▶ The operator is responsible for the operational safety and regulatory compliance of the heating system.

DANGER: Risk of personal injury or death from flue gas poisoning!

- ▶ Use a CO detector which gives an alarm in good time if CO escapes.
- ▶ The installer must verify that at least one carbon monoxide alarm has been installed within a residential living space or home following the alarm manufacturer's instructions and applicable local codes before putting the appliance into operation.
- ▶ Do not install a thermostatic flue gas damper downstream of the draft hood.
- ▶ Do not tamper with, remove, or attempt to repair the blocked vent switch.

- ▶ When replacing the blocked vent switch, install the new part in the original location.
- ▶ A blocked vent switch tripping more than once indicates a problem with the venting system or chimney which must be repaired immediately.
- ▶ Ensure none of the vent pipes and chimneys are damaged or blocked.
- ▶ Connect only one appliance to each venting system or chimney.
- ▶ The venting system must not feed into or route through another air extraction duct.
- ▶ The venting system must be inspected annually. All parts that show any signs of damage or corrosion must be replaced.
- ▶ Never close off or reduce the size of the combustion air openings.
- ▶ The boiler must not be operated until any obstructions have been removed.

DANGER: Risk of personal injury or death from explosion!

- ▶ Work on gas components may only be carried out by a trained and certified installer or service company.
- ▶ Appliance installation, the connection of gas and vent piping, initial commissioning, electrical connections, and service and maintenance must only be carried out by a trained and certified installer or service company.

DANGER: Risk of personal injury or death from fire!

- ▶ Do not use flammable or combustible material in the boiler room.
- ▶ It is recommended not to store any items within 16 inches (415mm) of the appliance

CAUTION: Appliance damage from contaminated combustion air!

- ▶ Keep the combustion air free of corrosive substances, e.g. halogenated hydrocarbons from painting operations or beauty salons.
- ▶ Keep combustion air free from dust and lint, e.g. from laundry or agricultural operations.
- ▶ If clean room air is not available, fresh outdoor combustion air must be provided

DANGER: Risk of personal injury or death from electric shock!

- ▶ Before removing the front panel, disconnect the heating system from the electrical power supply by shutting off the emergency shut-off switch or the heating system circuit breaker.
- ▶ It is not enough to switch off the control panel. **Power to the panel must be disconnected!** Ensure that the power is not restored unintentionally by following proper lock out/tag out procedures.
- ▶ Only qualified electricians are permitted to carry out electrical work.

DANGER: Safety devices!

- ▶ Never shut off safety valves!
- ▶ Hot water may escape from the safety valve at any time when the appliance is running.

DANGER: Risk of personal injury or death after a flood!

- ▶ Do not attempt to operate an appliance if any part of it has been under water.
- ▶ An appliance that was subject to flooding must be replaced.

NOTICE:

- ▶ Upon completion of the installation, these instructions should be handed to the owner and operator of the appliance.
- ▶ The installer must instruct the owner and operator on the functionality of the components and the proper operation of the boiler and the heating system.
- ▶ The boiler must be serviced annually including the main burner, ignition burner, the entire venting system, and the combustion air supply. All parts that show any signs of damage or corrosion must be replaced.

2 Scope of delivery

2.1 ZBR...-3A - Residential boiler for space heating and loading of indirect fired DHW tanks

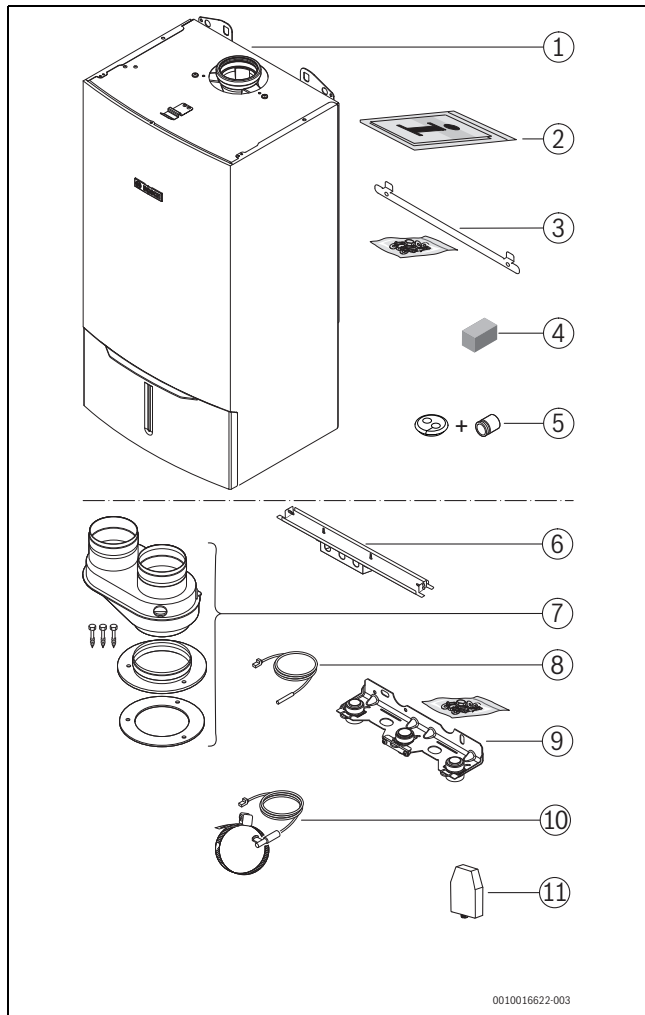

Fig. 1 Scope of delivery heating boiler ZBR...-3A

Contents of package 1:

- [1] Gas condensing boiler
- [2] Set of documents for appliance
- [3] Mounting bracket with mounting kit
- [4] Gas conversion kit
- [5] Adapter and cable grommet for connection of a LWCO

Contents of package 2:

- [6] Rail with connection box
- [7] Flue adapter¹⁾
- [8] DHW tank temperature sensor (NTC)
- [9] Hydraulics connection plate with mounting kit
- [10] External supply temperature sensor (NTC)
- [11] Outdoor temperature sensor

1) Concentric vent kit available as accessory.

2.2 ZWB...-3A - Residential combi boiler for space heating and DHW generation

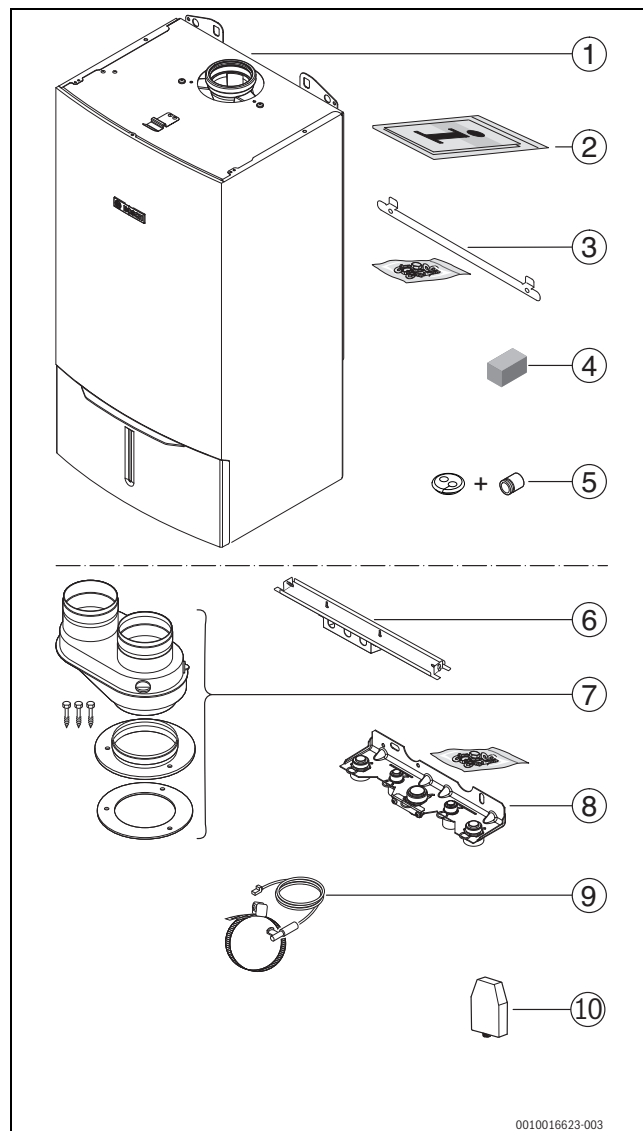

Fig. 2 Scope of delivery combi boiler ZWB...-3A

Contents of package 1:

- [1] Gas condensing boiler
- [2] Set of documents for appliance
- [3] Mounting bracket with mounting kit
- [4] Gas conversion kit
- [5] Adapter and cable grommet for connection of a LWCO

Contents of package 2:

- [6] Rail with connection box
- [7] Flue adapter²⁾
- [8] Hydraulics connection plate with mounting kit
- [9] External supply temperature sensor (NTC)
- [10] Outdoor temperature sensor

2) Concentric vent kit available as accessory.

3 Product Description

ZBR...-3A appliances are residential boilers for central heating and loading of an indirect fired DHW tank.

ZWB...-3A appliances are residential combi boilers for central heating and on demand DHW heating.

The appliances comply with South Coast Air Quality Management District (SCAQMD) 2012 requirements: (Type-1) 14 Ng/JNO_x (and/or 20 ppm at 3% O₂).

3.1 Proper use

The Greenstar boiler is not for use in CSD-1 commercial installation.

The appliance may only be installed in closed loop hot water central heating systems.

Any other purpose is considered improper use. Any resulting damage is excluded from the manufacturer's warranty.

The commercial and industrial use of the appliance for generating process heat is not permitted.

3.2 Overview of boiler types

ZBR21-3	A	23
ZBR28-3	A	23
ZBR35-3	A	23
ZBR42-3	A	23
ZWB28-3	A	23
ZWB35-3	A	23
ZWB42-3	A	23

Table 2 Appliance types

Z	Central heating appliance
W	DHW heating
B	Condensing technology
R	Constant temperature control
21	Output and DHW output up to 71,600 BTU/hr (21 kW)
28	Output and DHW output up to 95,500 BTU/hr (28 kW)
35	Output and DHW output up to 119,400 BTU/hr (35 kW)
42	Output and DHW output up to 143,300 BTU/hr (42 kW)
-3	Version
A	Fan-supported appliance
23	Natural gas (NG)

3.3 Rating plate

The rating plate is located at the right side of the appliance.

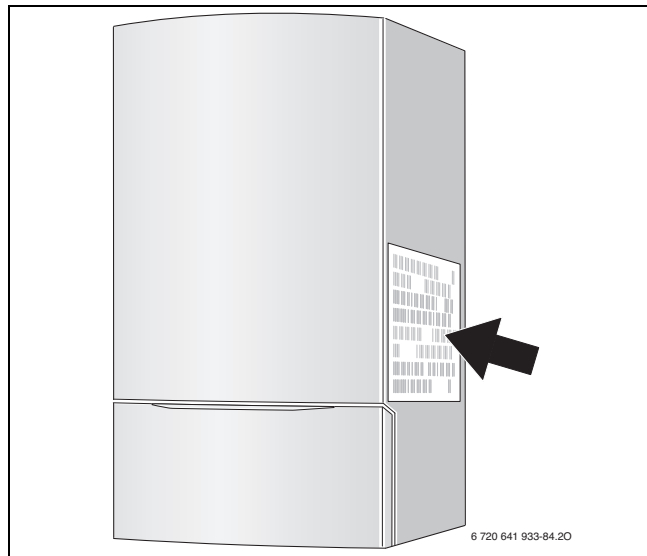

Fig. 3 Data plate location

The rating plate contains the appliance output, model number, approval data and serial number.

3.4 Appliance description

- Appliance for wall installation, regardless of chimney and room size
- Bosch Room Controller
- Intelligent boiler pump control
- Heatronic boiler control with 2-wire BUS
- Three-speed boiler circulator
- Automatic air vent (ZWB...-3A only)
- Display
- Automatic ignition
- Continuously-controlled output
- Full protection via the Heatronic with flame rod and solenoid valves
- No minimum circulating water flow rate required
- Suitable for radiant floor heating
- Flue adapter for flue gas and combustion air with test ports
- Variable speed fan
- Gas premix burner
- Temperature sensor and temperature control for space heating
- Supply temperature sensor
- Temperature limiter
- Safety relief valve, pressure gauge
- Expansion vessel (ZWB...-3A only)
- Connection possibility for DHW tank temperature sensor (NTC) (ZBR...-3A only)
- Flue gas temperature limiter
- DHW priority (ZWB...-3A only)
- Motorized 3-way valve (ZWB...-3A only)
- Hydraulics connection plate

3.5 Accessories



Refer to the Bosch Product Catalog for a complete overview of all available accessories.

3.6 Product dimensions and minimum clearances

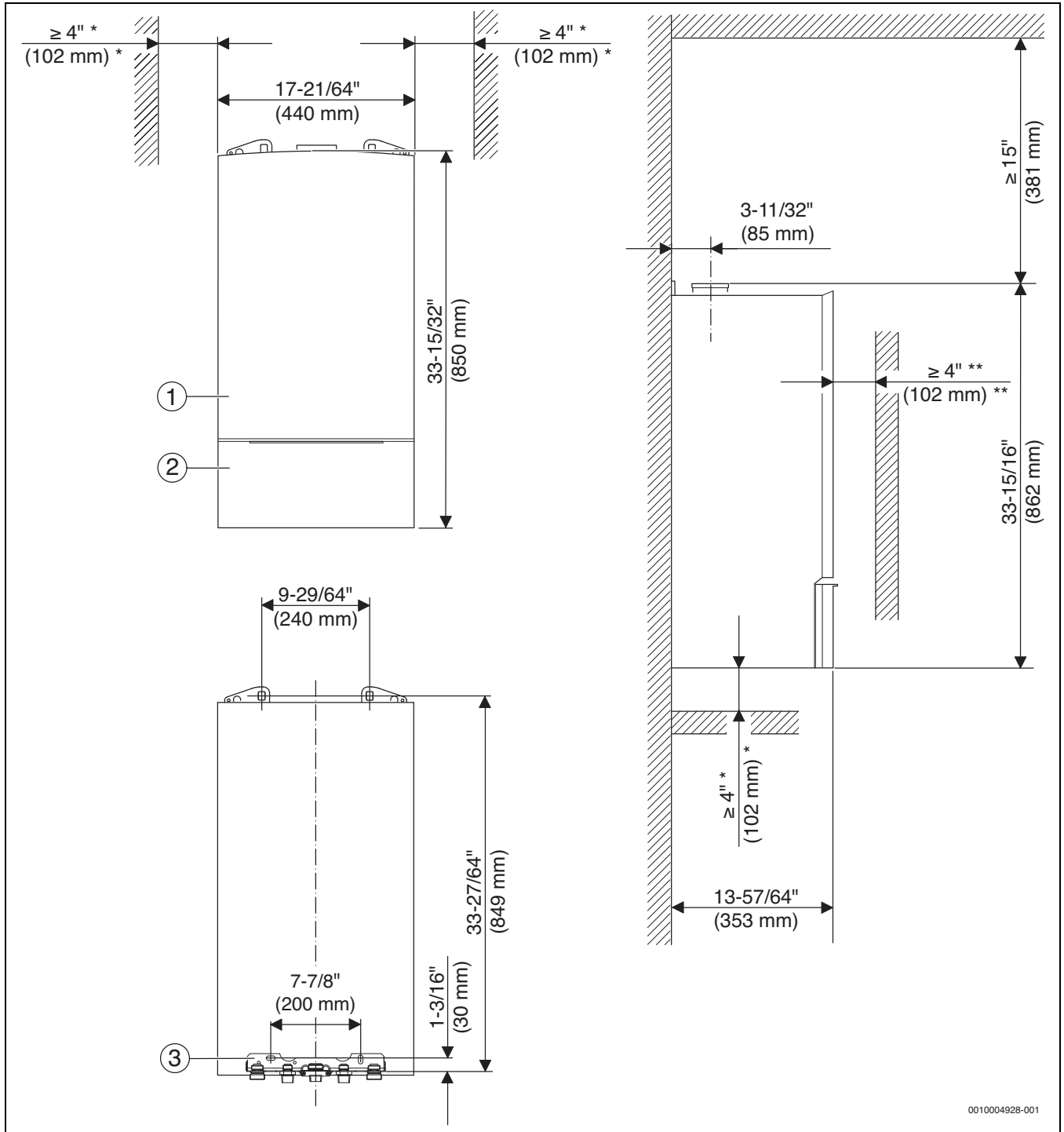
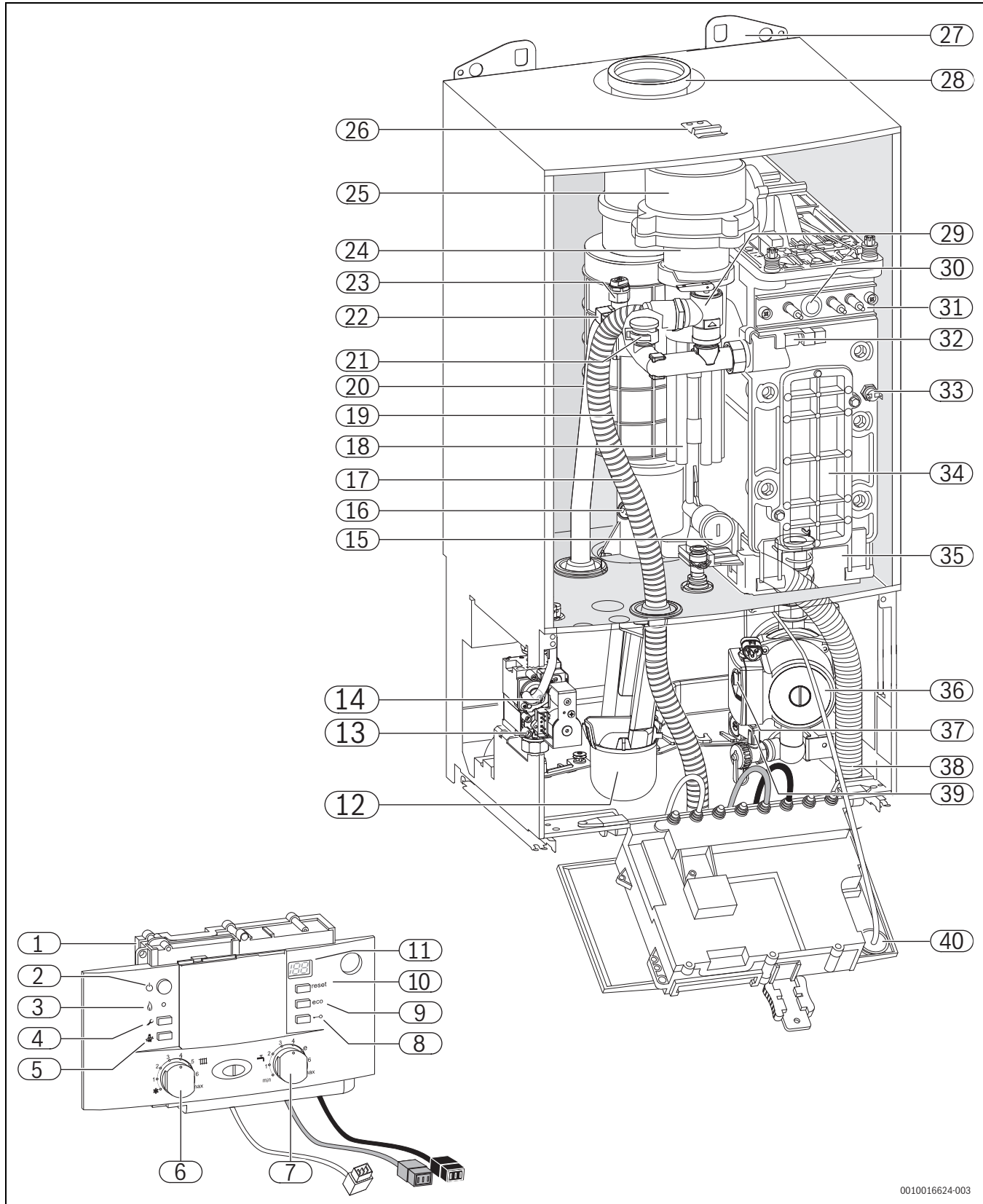

Fig. 4 Dimensions and minimum clearances (front view, rear view, side view)

- [1] Outer jacket complete
- [2] Front cover
- [3] Hydraulics connection plate
- (*) Zero clearance from combustibles permitted, but 4" (102 mm) recommended for serviceability
- (**) Distance to door, if mounted inside a closet

3.7 Appliance layout heating boiler ZBR...-3A



0010016624-003

Fig. 5 Appliance layout ZBR...-3A

Key to Fig. 5:

- [1] Heatronic boiler control
- [2] ON/OFF switch
- [3] Burner flame indicator
- [4] Service button
- [5] Emissions test button
- [6] Boiler high limit dial
- [7] DHW thermostat
- [8] Key pad lock
- [9] ECO button
- [10] Reset button
- [11] Display
- [12] Condensate trap
- [13] Test ports for inlet gas pressure
- [14] Adjustment screw, minimum gas volume
- [15] Maximum gas adjuster
- [16] Flue gas temperature limiter
- [17] Safety relief valve discharge hose
- [18] Combustion air intake
- [19] Exhaust pipe
- [20] Boiler supply pipe
- [21] Connection for optional low water cut off (LWCO)
- [22] Additional supply temperature limiter
- [23] Manual air bleeder
- [24] Gas/air premix chamber
- [25] Fan
- [26] Bracket
- [27] Wall hanging bracket
- [28] Exhaust pipe
- [29] Pressure relief valve (heating zone)
- [30] Sight glass
- [31] Set of electrodes
- [32] Supply temperature sensor
- [33] Boiler block temperature limiter
- [34] Inspection and cleanout cover
- [35] Condensate collector
- [36] Boiler circulator
- [37] Pump speed switch
- [38] Condensate drain hose
- [39] Drain cock
- [40] Boiler water pressure gauge

3.8 Appliance layout ZWB...-3A

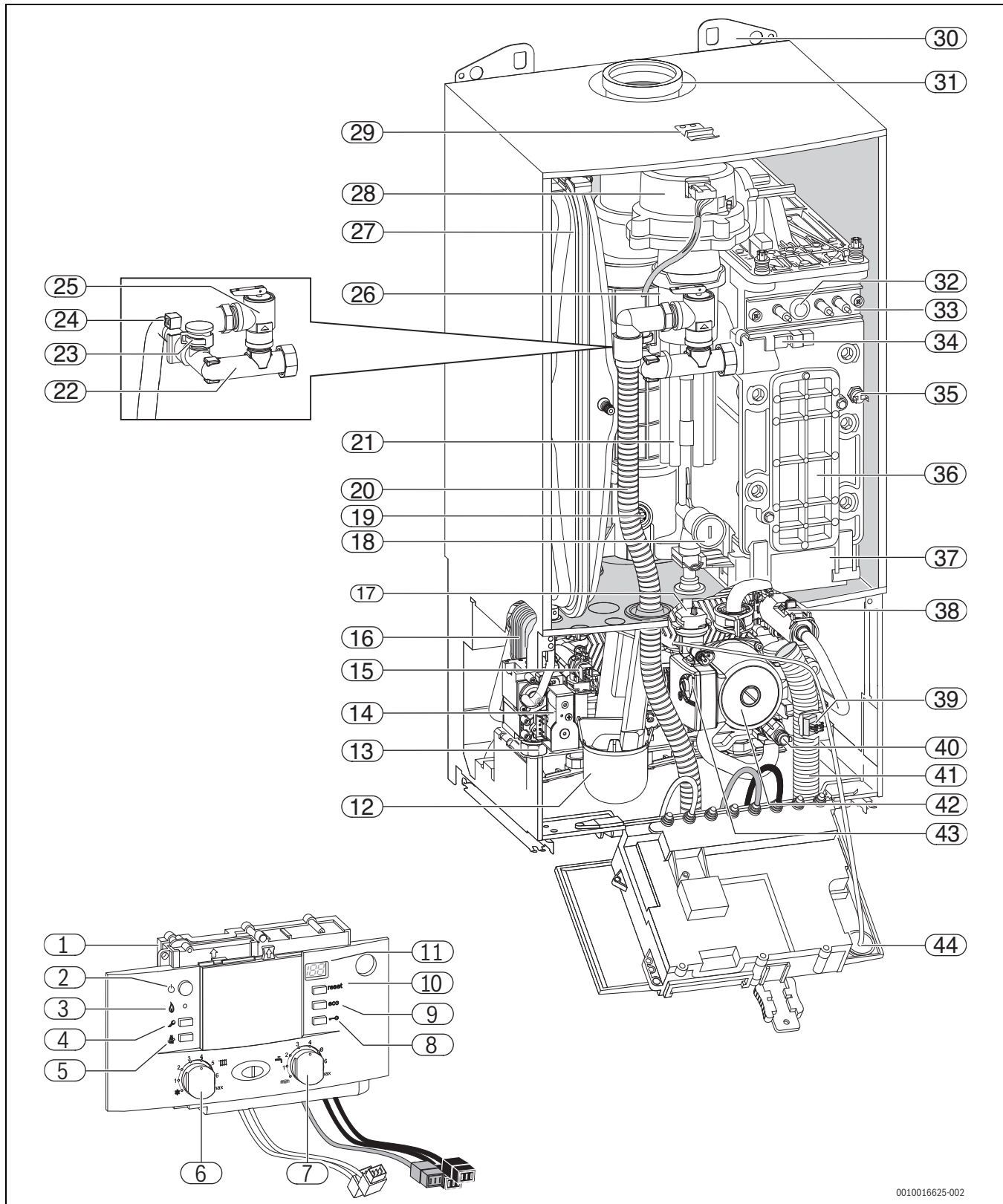

Fig. 6 Appliance layout ZWB...-3A

0010016625-002

Key to Fig. 6:

- [1] Heatronic boiler control
- [2] ON/OFF switch
- [3] Burner flame indicator
- [4] Service button
- [5] Emissions test button
- [6] Boiler high limit dial
- [7] DHW thermostat
- [8] Key pad lock
- [9] ECO button
- [10] Reset button
- [11] Display
- [12] Condensate trap
- [13] Test ports for inlet gas pressure
- [14] Adjustment screw, minimum gas volume
- [15] DHW temperature sensor
- [16] Plate-type heat exchanger
- [17] Automatic air vent
- [18] Maximum gas adjuster
- [19] Flue gas temperature limiter
- [20] Safety relief valve discharge hose
- [21] Combustion air intake
- [22] Supply pipe
- [23] Connection for optional low water cut off (LWCO)
- [24] Additional supply temperature limiter
- [25] Pressure relief valve (heating zone)
- [26] Gas/air premix chamber
- [27] Expansion vessel
- [28] Fan
- [29] Bracket
- [30] Wall hanging bracket
- [31] Exhaust pipe
- [32] Sight glass
- [33] Set of electrodes
- [34] Supply temperature sensor
- [35] Boiler block temperature limiter
- [36] Inspection and cleanout cover
- [37] Condensate collector
- [38] Flow meter
- [39] 3-way valve
- [40] Drain cock
- [41] Condensate drain hose
- [42] Boiler circulator
- [43] Pump speed switch
- [44] Boiler water pressure gauge

3.9 Electrical wiring ZBR...-3A

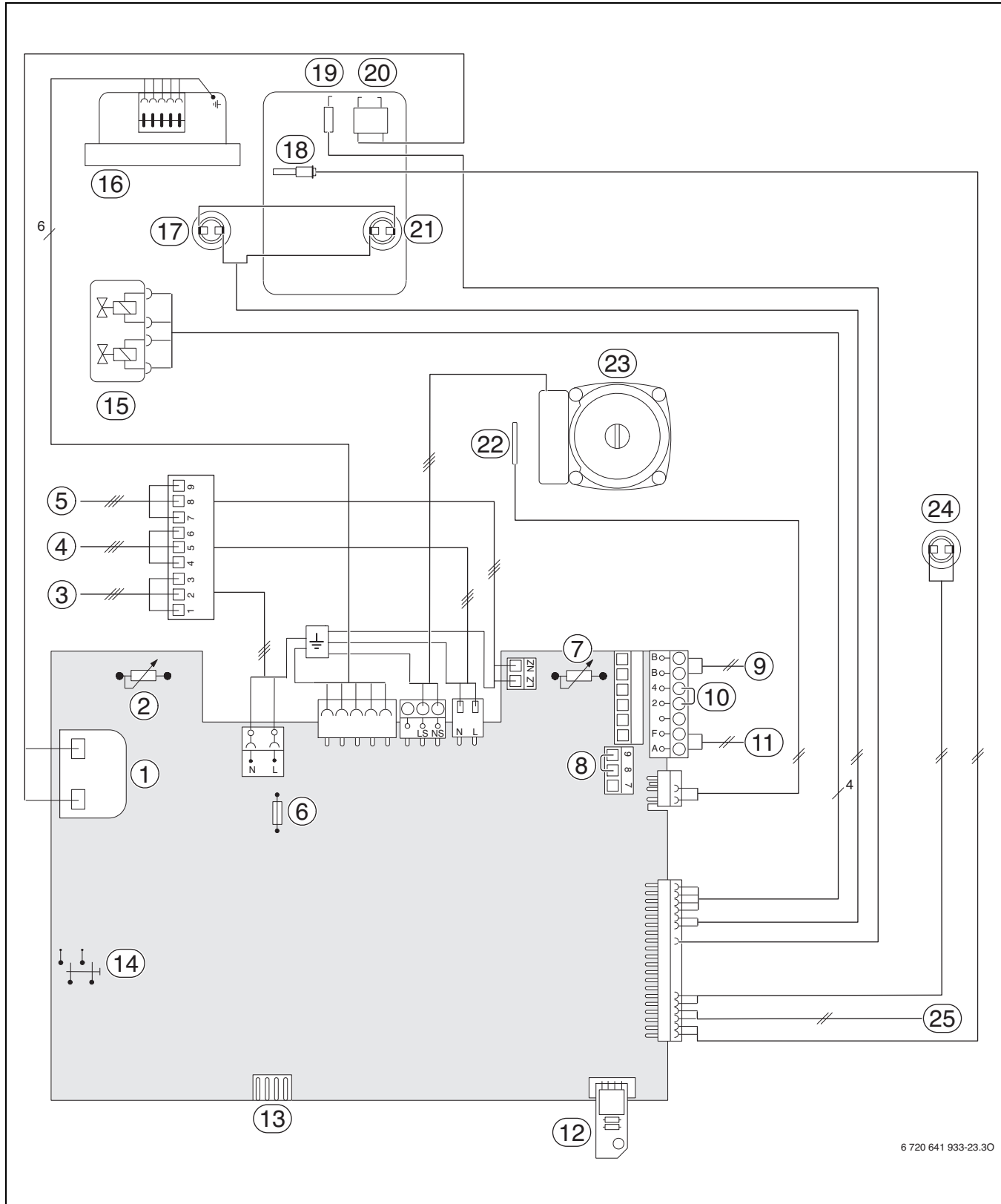

6 720 641 933-23.30

Fig. 7 Electrical wiring diagram ZBR...-3A

Key to Fig. 7:

- [1] Ignition transformer
- [2] Boiler high limit dial
- [3] 120 VAC connection
- [4] DHW tank primary pump or 3-way valve ¹⁾
- [5] External heating pump for unmixed heating circuit (secondary circuit) 5 or DHW recirculation pump ²⁾
- [6] Fuse T 6.3 A (120 VAC)
- [7] DHW thermostat
- [8] External safety high limit or low water cut off (LWCO)
- [9] BUS connection, e.g. heating control
- [10] Room thermostat – dry contact
- [11] Outdoor temperature sensor
- [12] Code plug
- [13] Diagnostic interface
- [14] ON/OFF switch
- [15] Gas valve
- [16] Fan
- [17] Flue gas temperature limiter
- [18] Supply temperature sensor
- [19] Flame rod electrode
- [20] Ignition electrode
- [21] Boiler block temperature limiter
- [22] DHW tank temperature sensor (NTC)
- [23] Boiler circulator
- [24] Additional supply temperature limiter
- [25] External system supply temperature sensor

1) Set the service function 1.F, → page 57.

2) Set the service function 5.E, → page 59.

3.10 Electrical wiring ZWB...-3A

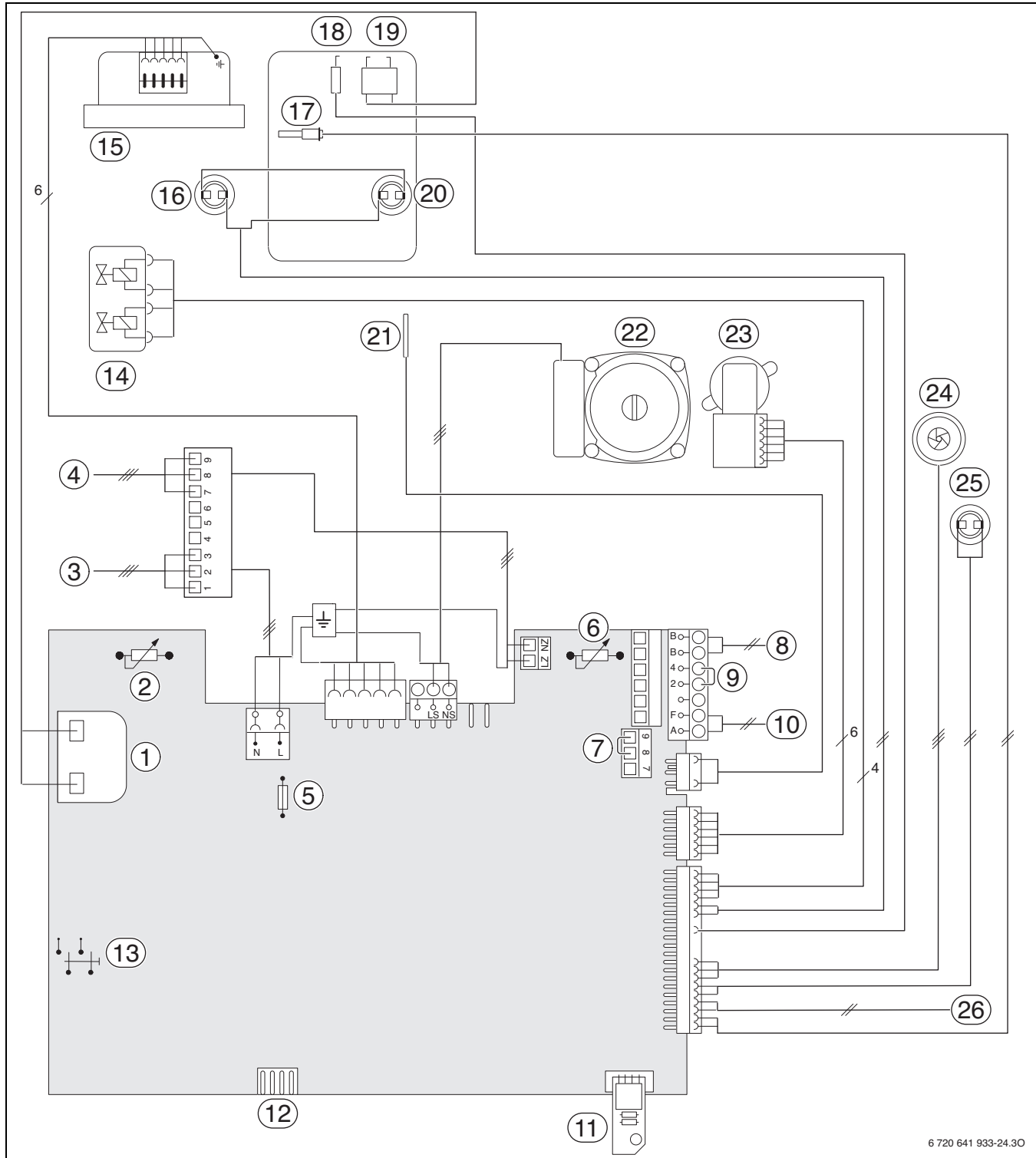

6 720 641 933-24.30

Fig. 8 Electrical wiring diagram ZWB...-3A

Key to Fig. 8:

- [1] Ignition transformer
- [2] Boiler high limit dial
- [3] 120 VAC connection
- [4] External heating pump for unmixed heating circuit (secondary circuit) 4 or DHW recirculation pump ¹⁾
- [5] Fuse T 6.3 A (120 VAC)
- [6] DHW thermostat
- [7] External safety high limit or low water cut off (LWCO)
- [8] BUS connection, e.g. heating control
- [9] Room thermostat – dry contact
- [10] Outdoor temperature sensor
- [11] Code plug
- [12] Diagnostic interface
- [13] ON/OFF switch
- [14] Gas valve
- [15] Fan
- [16] Flue gas temperature limiter
- [17] Supply temperature sensor
- [18] Flame rod electrode
- [19] Ignition electrode
- [20] Boiler block temperature limiter
- [21] DHW temperature sensor
- [22] Boiler circulator
- [23] 3-way valve (Space heating/DHW heating)
- [24] Flow meter (turbine)
- [25] Additional supply temperature limiter
- [26] External system supply temperature sensor

1) Set the service function 5.E, → page 56.

3.11 Technical data ZBR...-3A

Input/Output	Unit	ZBR 21-3 A...	
		NG	LPG (propane)
Max. input rate 180/79 °F (82/26 °C)	BTU/hr (kW)	79,200 (23.2)	77,500 (22.7)
Max. output rate 104/86 °F (40/30 °C)	BTU/hr (kW)	74,700 (21.9)	74,700 (21.9)
Max. output rate 122/86 °F (50/30 °C)	BTU/hr (kW)	74,000 (21.7)	74,000 (21.7)
Max. output rate 176/140 °F (80/60 °C)	BTU/hr (kW)	70,300 (20.6)	70,300 (20.6)
Min. input rate 180/79 °F (82/26 °C)	BTU/hr (kW)	24,600 (7.2)	40,100 (11.7)
Min. output rate 104/86 °F (40/30 °C)	BTU/hr (kW)	23,900 (7.0)	39,900 (11.7)
Min. output rate 122/86 °F (50/30 °C)	BTU/hr (kW)	23,900 (7.0)	39,600 (11.6)
Min. output rate 176/140 °F (80/60 °C)	BTU/hr (kW)	21,800 (6.4)	36,200 (10.6)
Gas connection value			
Natural Gas – H ₂ = 1,010 BTU/ft ³ (37.3 MJ/m ³)	ft ³ /hr (m ³ /h)	78 (2.2)	–
Liquid Propane Gas – H _{D,S} = 2,500 BTU/ft ³ (93.1 MJ/m ³)	ft ³ /hr (m ³ /h)	–	31 (0.9)
Permissible inlet gas pressure			
NG	in. W.C. (mbar)	3.5-10.5" (8.7-26.1)	–
LPG (propane)	in. W.C. (mbar)	–	8-13" (19.9-32.3)
Flue gas			
Flue gas mass flow at maximum/minimum nominal output	g/s	9.4/3.2	9.2/4.8
Flue gas temperature 176/140 °F (80/60 °C) at maximum/minimum nominal heat input	°F (°C)	145/133 (63/56)	145/133 (63/56)
Flue gas temperature 104/86 °F (40/30 °C) at maximum/minimum nominal heat input	°F (°C)	115/90 (46/32)	115/90 (46/32)
CO ₂ at max. nominal output	%	9.4	11.0
CO ₂ at minimum nominal output	%	8.6	10.4
Condensate			
Max. condensate quantity (t _R = 86 °F (30 °C))	gph (l/h)	0.5 (1.8)	0.5 (1.8)
pH level, approx.		4.8	4.8
General			
Voltage	V AC	120	120
Frequency	Hz	60	60
Max. power consumption (central heating mode)	W	205	205
Max. power consumption (Stand-by)	W	< 6	< 6
Sound pressure level	dB(A)	≤ 39	≤ 39
Max. supply temperature	°F (°C)	187 (86)	187 (86)
Max. permissible operating pressure (P _{MS}) heating	psi (bar)	30 (2.07)	30 (2.07)
Permissible ambient temperature	°F (°C)	32 - 122 (0 - 50)	32 - 122 (0 - 50)
Nominal water capacity (heating)	gal (l)	0.925 (3.5)	0.925 (3.5)
Weight (without packaging)	lbs. (kg)	103.6 (47)	103.6 (47)
Dimensions, W x H x D	inch (mm)	17-21/64" × 33-15/32" 13-57/64" (440 × 850 × 353)	

Table 3 Technical data ZBR 21-3 A...

Input/Output	Unit	ZBR 28-3 A...		ZBR 35-3 A...	
		NG	LPG (propane)	NG	LPG (propane)
Max. input rate 180/79 °F (82/26 °C)	BTU/hr (kW)	100,800 (29.5)	98,600 (28.9)	131,900 (38.6)	129,100 (37.8)
Max. output rate 104/86 °F (40/30 °C)	BTU/hr (kW)	93,800 (27.5)	93,800 (27.5)	122,800 (36.0)	122,800 (36.0)
Max. output rate 122/86 °F (50/30 °C)	BTU/hr (kW)	93,100 (27.3)	93,100 (27.3)	121,800 (35.7)	121,800 (35.7)
Max. output rate 176/140 °F (80/60 °C)	BTU/hr (kW)	89,400 (26.2)	89,400 (26.2)	116,700 (34.2)	116,700 (34.2)
Min. input rate 180/79 °F (82/26 °C)	BTU/hr (kW)	24,600 (7.2)	40,100 (11.7)	36,000 (10.5)	46,400 (13.6)
Min. output rate 104/86 °F (40/30 °C)	BTU/hr (kW)	23,900 (7.0)	39,900 (11.7)	35,100 (10.3)	46,100 (13.5)
Min. output rate 122/86 °F (50/30 °C)	BTU/hr (kW)	23,900 (7.0)	39,600 (11.6)	34,800 (10.2)	45,700 (13.4)
Min. output rate 176/140 °F (80/60 °C)	BTU/hr (kW)	21,800 (6.4)	36,200 (10.6)	31,700 (9.3)	42,000 (12.3)
Gas connection value					
Natural Gas – H _s = 1,010 BTU/ft ³ (37.3MJ/m ³)	ft ³ /hr (m ³ /h)	99 (2.8)	–	130 (3.7)	–
Liquid Propane Gas – H _{D,S} = 2,500 BTU/ft ³ (93.1MJ/m ³)	ft ³ /hr (m ³ /h)	–	39 (1.1)	–	52 (1.5)
Permissible inlet gas pressure					
NG	in. W.C. (mbar)	3.5-10.5" (8.7-26.1)	–	3.5-10.5 (8.7-26.1)	–
LPG (propane)	in. W.C. (mbar)	–	8-13" (19.9-32.3)	–	8-13 (19.9-32.3)
Flue gas					
Flue gas mass flow at maximum/minimum nominal output	g/s	12.0/3.2	11.6/4.8	15.7/4.5	15.2/5.6
Flue gas temperature 176/140 °F (80/60 °C) at maximum/minimum nominal heat input	°F (°C)	147/133 (64/56)	147/133 (64/56)	162/135 (72/57)	162/135 (72/57)
Flue gas temperature 104/86 °F (40/30 °C) at maximum/minimum nominal heat input	°F (°C)	117/90 (47/32)	117/90 (47/32)	127/91 (53/33)	127/91 (53/33)
CO ₂ at max. nominal output	%	9.4	11.0	9.4	11.0
CO ₂ at minimum nominal output	%	8.6	10.4	8.6	10.4
Condensate					
Max. condensate quantity (t _R = 86 °F (30 °C))	gph (l/h)	0.6 (2.3)	0.6 (2.3)	0.8 (3.1)	0.8 (3.1)
pH level, approx.		4.8	4.8	4.8	4.8
General					
Voltage	VAC	120	120	120	120
Frequency	Hz	60	60	60	60
Max. power consumption (central heating mode)	W	205	205	205	205
Max. power consumption (Stand-by)	W	< 6	< 6	< 6	< 6
Sound pressure level	dB(A)	≤ 39	≤ 39	≤ 44	≤ 44
Max. supply temperature	°F (°C)	187 (86)	187 (86)	187 (86)	187 (86)
Max. permissible operating pressure (P _{MS}) heating	psi (bar)	30 (2.07)	30 (2.07)	30 (2.07)	30 (2.07)
Permissible ambient temperature	°F (°C)	32 - 122 (0 - 50)	32 - 122 (0 - 50)	32 - 122 (0 - 50)	32 - 122 (0 - 50)
Nominal water capacity (heating)	gal (l)	0.925 (3.5)	0.925 (3.5)	0.925 (3.5)	0.925 (3.5)
Weight (without packaging)	lbs. (kg)	103.6 (47)	103.6 (47)	103.6 (47)	103.6 (47)
Dimensions, W x H x D	inch (mm)	17-21/64" × 33-15/32"13-57/64" (440 × 850 × 353)		17-21/64" × 33-15/32"13-57/64" (440 × 850 × 353)	

Table 4 Technical data ZBR 28-3 A..., ZBR 35-3 A...

Input/Output at elevation 0 - 2000 feet (0 - 610 m)	Unit	ZBR 42-3 A...	
		NG	LPG (propane)
Max. input rate 180/79 °F (82/26 °C)	BTU/hr (kW)	151,600 (44.4)	148,300 (43.5)
Max. output rate 104/86 °F (40/30 °C)	BTU/hr (kW)	137,500 (40.3)	137,500 (40.3)
Max. output rate 122/86 °F (50/30 °C)	BTU/hr (kW)	137,500 (40.3)	137,500 (40.3)
Max. output rate 176/140 °F (80/60 °C)	BTU/hr (kW)	134,400 (39.4)	134,400 (39.4)
Min. input rate 180/79 °F (82/26 °C)	BTU/hr (kW)	36,000 (10.5)	46,400 (13.6)
Min. output rate 104/86 °F (40/30 °C)	BTU/hr (kW)	35,500 (10.4)	46,400 (13.6)
Min. output rate 122/86 °F (50/30 °C)	BTU/hr (kW)	35,100 (10.3)	46,100 (13.5)
Min. output rate 176/140 °F (80/60 °C)	BTU/hr (kW)	31,700 (9.3)	42,000 (12.3)
Input/Output at elevation 2000 - 4500 feet (611 - 1372 m) above sea level			
Max. input rate 180/79 °F (82/26 °C)	BTU/hr (kW)	136,440 (40.0)	139,402 (40.9)
Max. output rate 104/86 °F (40/30 °C)	BTU/hr (kW)	123,750 (36.3)	129,250 (37.9)
Max. output rate 122/86 °F (50/30 °C)	BTU/hr (kW)	123,750 (36.3)	129,250 (37.9)
Max. output rate 176/140 °F (80/60 °C)	BTU/hr (kW)	120,960 (35.5)	126,336 (37.0)
Input/Output at elevation 4500 - 7000 feet (1373 - 2134 m) above sea level			
Max. input rate 180/79 °F (82/26 °C)	BTU/hr (kW)	125,828 (36.9)	129,021 (37.8)
Max. output rate 104/86 °F (40/30 °C)	BTU/hr (kW)	114,125 (33.5)	119,625 (35.1)
Max. output rate 122/86 °F (50/30 °C)	BTU/hr (kW)	114,125 (33.5)	119,625 (35.1)
Max. output rate 176/140 °F (80/60 °C)	BTU/hr (kW)	111,552 (32.7)	116,928 (34.3)
Gas connection value			
Natural Gas – H _s = 1,010 BTU/ft ³ (37.3MJ/m ³)	ft ³ /hr (m ³ /h)	149 (4.2)	-
Liquid Propane Gas – H _{D-S} = 2,500 BTU/ft ³ (93.1MJ/m ³)	ft ³ /hr (m ³ /h)	-	59 (1.7)
Permissible inlet gas pressure			
NG	in. W.C. (mbar)	3.5-10.5 (8.7-26.1)	-
LPG (propane)	in. W.C. (mbar)	-	8-13 (19.9-32.3)
Flue gas			
Flue gas mass flow at maximum/minimum nominal output	g/s	18.0/4.5	17.5/5.6
Flue gas temperature 176/140 °F (80/60 °C) at maximum/minimum nominal heat input	°F (°C)	171/135 (77/57)	171/135 (77/57)
Flue gas temperature 104/86 °F (40/30 °C) at maximum/minimum nominal heat input	°F (°C)	133/91 (56/33)	133/91 (56/33)
CO ₂ at max. nominal output	%	9.4	11.0
CO ₂ at minimum nominal output	%	8.6	10.4
Condensate			
Max. condensate quantity (t _R = 86 °F (30 °C))	gph (l/h)	0.9 (3.5)	0.9 (3.5)
pH level, approx.		4.8	4.8
General			
Voltage	VAC	120	120
Frequency	Hz	60	60
Max. power consumption (central heating mode)	W	205	205
Max. power consumption (Stand-by)	W	< 6	< 6
Sound pressure level	dB(A)	≤ 45	≤ 45
Max. supply temperature	°F (°C)	187 (86)	187 (86)
Max. permissible operating pressure (P _{MS}) heating	psi (bar)	30 (2.07)	30 (2.07)
Permissible ambient temperature	°F (°C)	32 - 122 (0 - 50)	32 - 122 (0 - 50)
Nominal water capacity (heating)	gal (l)	0.925 (3.5)	0.925 (3.5)
Weight (without packaging)	lbs. (kg)	103.6 (47)	103.6 (47)
Dimensions, W x H x D	inch (mm)	17-21/64" × 33-15/32"13-57/64" (440 × 850 × 353)	

Table 5 Technical data ZBR 42-3 A...

3.12 Technical data ZWB...-3A

Input/Output	Unit	ZWB 28-3 A...		ZWB 35-3 A...	
		NG	LPG (propane)	NG	LPG (propane)
Max. input rate 180/79 °F (82/26 °C)	BTU/hr (kW)	100,800 (29.5)	98,600 (28.9)	131,900 (38.6)	129,100 (37.8)
Max. output rate 104/86 °F (40/30 °C)	BTU/hr (kW)	93,800 (27.5)	93,800 (27.5)	122,800 (36.0)	122,800 (36.0)
Max. output rate 122/86 °F (50/30 °C)	BTU/hr (kW)	93,100 (27.3)	93,100 (27.3)	121,800 (35.7)	121,800 (35.7)
Max. output rate 176/140 °F (80/60 °C)	BTU/hr (kW)	89,400 (26.2)	89,400 (26.2)	116,700 (34.2)	116,700 (34.2)
Output rate domestic hot water (DHW), 113 °F (45 °C)	BTU/hr (kW)	93,600 (27.4)	93,600 (27.4)	120,500 (35.3)	120,500 (35.3)
Output rate domestic hot water (DHW), 140 °F (60 °C)	BTU/hr (kW)	91,400 (26.8)	91,400 (26.8)	118,700 (34.8)	118,700 (34.8)
Min. input rate 180/79 °F (82/26 °C)	BTU/hr (kW)	24,600 (7.2)	40,100 (11.7)	36,000 (10.5)	46,400 (13.6)
Min. output rate 104/86 °F (40/30 °C)	BTU/hr (kW)	23,900 (7.0)	39,900 (11.7)	35,100 (10.3)	46,100 (13.5)
Min. output rate 122/86 °F (50/30 °C)	BTU/hr (kW)	23,900 (7.0)	39,600 (11.6)	34,800 (10.2)	45,700 (13.4)
Min. output rate 176/140 °F (80/60 °C)	BTU/hr (kW)	21,800 (6.4)	36,200 (10.6)	31,700 (9.3)	42,000 (12.3)
Gas connection value					
Natural Gas – H _s = 1,010 BTU/ft ³ (37.3MJ/m ³)	BTU/ft ³ (MJ/m ³)	99 (2.8)	–	130 (3.7)	–
Liquid Propane Gas – H _{D-S} = 2,500 BTU/ft ³ (93.1MJ/m ³)	BTU/ft ³ (MJ/m ³)	–	39 (1.1)	–	52 (1.5)
Permissible inlet gas pressure					
NG	in. W.C. (mbar)	3.5-10.5 (8.7-26.1)	–	3.5-10.5" (8.7-26.1)	–
LPG (propane)	in. W.C. (mbar)	–	8-13 (19.9-32.3)	–	8-13" (19.9-32.3)
Expansion vessel					
Pre-charge pressure	psi (bar)	10.9 (0.75)	10.9 (0.75)	10.9 (0.75)	10.9 (0.75)
Total contents	gal (l)	3.17 (12)	3.17 (12)	3.17 (12)	3.17 (12)
DHW					
Max. DHW flow rate	gpm (l/min)	2.64 (10)	2.64 (10)	3.17 (12)	3.17 (12)
Nominal DHW flow rate (at 140 °F (60 °C) outlet temperature)	gpm (l/min)	2.03 (7.7)	2.03 (7.7)	2.6 (10)	2.6 (10)
Outlet temperature	°F (°C)	104 - 140 (40 - 60)	104 - 140 (40 - 60)	104 - 140 (40 - 60)	104 - 140 (40 - 60)
Max. cold water inlet temperature	°F (°C)	140 (60)	140 (60)	140 (60)	140 (60)
Max. approved DHW pressure	psi (bar)	150 (10.3)	150 (10.3)	150 (10.3)	150 (10.3)
Minimum water pressure	psi (bar)	4.35 (0.3)	4.35 (0.3)	4.35 (0.3)	4.35 (0.3)
Flue gas					
Flue gas mass flow at maximum/minimum nominal output	g/s	12.0/3.2	11.7/4.9	15.7/4.5	15.2/5.6
Flue gas temperature 176/140 °F (80/60 °C) at maximum/minimum nominal heat input	°F (°C)	147/133 (64/56)	147/133 (64/56)	162/135 (72/57)	162/135 (72/57)
Flue gas temperature 104/86 °F (40/30 °C) at maximum/minimum nominal heat input	°F (°C)	117/90 (4/32)	117/90 (47/32)	127/91 (53/33)	127/91 (53/33)
CO ₂ at max. nominal output	%	9.4	11.0	9.4	11.0
CO ₂ at minimum nominal output	%	8.6	10.4	8.6	10.4
Condensate					
Max. condensate quantity (t _R = 86 °F (30 °C))	gph (l/h)	0.6 (2.3)	0.6 (2.3)	0.8 (3.1)	0.8 (3.1)
pH level, approx.		4.8	4.8	4.8	4.8
General					
Voltage	VAC	120	120	120	120
Frequency	Hz	60	60	60	60
Max. power consumption (central heating mode)	W	205	205	205	205
Max. power consumption (Stand-by)	W	< 6	< 6	< 6	< 6
Sound pressure level	dB(A)	≤ 39	≤ 39	≤ 44	≤ 44
Max. supply temperature	°F (°C)	187 (86)	187 (86)	187 (86)	187 (86)
Max. permissible operating pressure (P _{MS}) heating	psi (bar)	30 (2.07)	30 (2.07)	30 (2.07)	30 (2.07)
Permissible ambient temperature	°F (°C)	32 - 122 (0 - 50)	32 - 122 (0 - 50)	32 - 122 (0 - 50)	32 - 122 (0 - 50)
Nominal water capacity (heating)	gal (l)	0.925 (3.5)	0.925 (3.5)	0.925 (3.5)	0.925 (3.5)
Weight (without packaging)	lbs. (kg)	110.2 (50)	110.2 (50)	110.2 (50)	110.2 (50)
Dimensions, W x H x D	inch (mm)	17-21/64" x 33-15/32"13-57/64" (440 x 850 x 353)		17-21/64" x 33-15/32"13-57/64" (440 x 850 x 353)	

Table 6 Technical data ZWB28-3A..., ZWB35-3A...

Input/Output at elevation 0 - 2000 feet (0 - 610 m)	Unit	ZWB 42-3 A...	
		NG	LPG (propane)
Max. input rate 180/79 °F (82/26 °C)	BTU/hr (kW)	151,600 (44.4)	148,300 (43.5)
Max. output rate 104/86 °F (40/30 °C)	BTU/hr (kW)	137,500 (40.3)	137,500 (40.3)
Max. output rate 122/86 °F (50/30 °C)	BTU/hr (kW)	137,500 (40.3)	137,500 (40.3)
Max. output rate 176/140 °F (80/60 °C)	BTU/hr (kW)	134,400 (39.4)	134,400 (39.4)
Output rate domestic hot water (DHW), 113 °F (45 °C)	BTU/hr (kW)	137,500 (40.3)	137,500 (40.3)
Output rate domestic hot water (DHW), 140 °F (60 °C)	BTU/hr (kW)	135,800 (39.8)	135,800 (39.8)
Min. input rate 180/79 °F (82/26 °C)	BTU/hr (kW)	36,000 (10.5)	46,400 (13.6)
Min. output rate 104/86 °F (40/30 °C)	BTU/hr (kW)	35,500 (10.4)	46,400 (13.6)
Min. output rate 122/86 °F (50/30 °C)	BTU/hr (kW)	35,100 (10.3)	46,100 (13.5)
Min. output rate 176/140 °F (80/60 °C)	BTU/hr (kW)	31,700 (9.3)	42,000 (12.3)
Input/Output at elevation 2000 - 4500 feet (611 - 1372 m) above sea level			
Max. input rate 180/79 °F (82/26 °C)	BTU/hr (kW)	136,440 (40.0)	139,402 (40.9)
Max. output rate 104/86 °F (40/30 °C)	BTU/hr (kW)	123,750 (36.3)	129,250 (37.9)
Max. output rate 122/86 °F (50/30 °C)	BTU/hr (kW)	123,750 (36.3)	129,250 (37.9)
Max. output rate 176/140 °F (80/60 °C)	BTU/hr (kW)	120,960 (35.5)	126,336 (37.0)
Output rate domestic hot water (DHW), 113 °F (45 °C)	BTU/hr (kW)	123,750 (36.3)	129,250 (37.9)
Output rate domestic hot water (DHW), 140 °F (60 °C)	BTU/hr (kW)	122,220 (35.8)	127,652 (37.4)
Input/Output at elevation 4500 - 7000 feet (1373 - 2134 m) above sea level			
Max. input rate 180/79 °F (82/26 °C)	BTU/hr (kW)	125,828 (36.9)	129,021 (37.8)
Max. output rate 104/86 °F (40/30 °C)	BTU/hr (kW)	114,125 (33.5)	119,625 (35.1)
Max. output rate 122/86 °F (50/30 °C)	BTU/hr (kW)	114,125 (33.5)	119,625 (35.1)
Max. output rate 176/140 °F (80/60 °C)	BTU/hr (kW)	111,552 (32.7)	116,928 (34.3)
Output rate domestic hot water (DHW), 113 °F (45 °C)	BTU/hr (kW)	114,125 (33.5)	119,625 (35.1)
Output rate domestic hot water (DHW), 140 °F (60 °C)	BTU/hr (kW)	112,714 (33.0)	118,146 (34.6)
Gas connection value			
Natural Gas – H _s = 1,010 BTU/ft ³ (37.3MJ/m ³)	BTU/ft ³ (MJ/m ³)	149 (4.2)	–
Liquid Propane Gas – H _{D-S} = 2,500 BTU/ft ³ (93.1MJ/m ³)	BTU/ft ³ (MJ/m ³)	–	59 (1.7)
Permissible inlet gas pressure			
NG	" W.C. (mbar)	3.5-10.5 (8.7-26.1)	–
LPG (propane)	" W.C. (mbar)	–	8-13 (19.9-32.3)
Expansion vessel			
Pre-charge pressure	psi (bar)	10.9 (0.75)	10.9 (0.75)
Total contents	gal (l)	3.17 (12)	3.17 (12)
DHW			
Max. DHW flow rate	gpm (l/min)	3.963 (15)	3.963 (15)
Nominal DHW flow rate (at 140 °F (60 °C) outlet temperature)	gpm (l/min)	3.61 (11.4)	3.61 (11.4)
Outlet temperature	°F (°C)	104 - 140 (40 - 60)	104 - 140 (40 - 60)
Max. cold water inlet temperature	°F (°C)	140 (60)	140 (60)
Max. approved DHW pressure	psi (bar)	150 (10.3)	150 (10.3)
Minimum water pressure	psi (bar)	4.35 (0.3)	4.35 (0.3)
Flue gas			
Flue gas mass flow at maximum/minimum nominal output	g/s	18.0/4.5	17.5/5.6
Flue gas temperature 176/140 °F (80/60 °C) at maximum/minimum nominal heat input	°F (°C)	171/135 (77/57)	171/135 (77/57)
Flue gas temperature 104/86 °F (40/30 °C) at maximum/minimum nominal heat input	°F (°C)	133/91 (56/33)	133/91 (56/33)
CO ₂ at max. nominal output	%	9.4	11.0
CO ₂ at minimum nominal output	%	8.6	10.4
Condensate			
Max. condensate quantity (t _R = 86 °F (30 °C))	gph (l/h)	0.9 (3.5)	0.9 (3.5)
pH level, approx.	–	4.8	4.8
General			
Voltage	AC ... V	120	120
Frequency	Hz	60	60
Max. power consumption (central heating mode)	W	205	205
Max. power consumption (Stand-by)	W	< 6	< 6

Input/Output at elevation 0 - 2000 feet (0 - 610 m)	Unit	ZWB 42-3 A...	
		NG	LPG (propane)
Sound pressure level	dB(A)	≤ 45	≤ 45
Max. supply temperature	°F (°C)	187 (86)	187 (86)
Max. permissible operating pressure (P _{MS}) heating	psi (bar)	30 (2.07)	30 (2.07)
Permissible ambient temperature	°F (°C)	32 - 122 (0 - 50)	32 - 122 (0 - 50)
Nominal water capacity (heating)	gal (l)	0.925 (3.5)	0.925 (3.5)
Weight (without packaging)	lbs. (kg)	110.2 (50)	110.2 (50)
Dimensions, W x H x D	inch (mm)	17-21/64" x 33-15/32"13-57/64" (440 x 850 x 353)	

Table 7 Technical data ZWB42-3A...

3.13 Condensate composition

The condensate volume and ingredients may change with regionally and seasonally varying gas quality and air quality. Typically the following ingredients and concentrations can be expected:

Substance	Value in ppm (mg/l)
Ammonium	1.2
Lead	≤ 0.01
Cadmium	≤ 0.001
Chrome	≤ 0.005
Halogenated hydrocarbons	≤ 0.002
Hydrocarbons	0.015
Copper	0.028
Nickel	≤ 0.1
Mercury	≤ 0.0001
Sulfate	1
Zinc	≤ 0.015
Tin	≤ 0.01
Vanadium	≤ 0.001
pH-value	4.8

Table 8 Typical condensate composition

4 Regulations



Observe all rules, regulations, standards and guidelines applicable to the installation and operation of this appliance in your country.



Valves external to the boiler must be fitted with T-handles and condensate piping must be installed in accordance with the State Plumbing Code.

4.1 Compliance with standards and regulations

The installation must conform to the requirements of the authority having jurisdiction or, in the absence of such requirements, to the latest edition of the National Fuel Gas Code, ANSI Z223.1./NFPA 54. In Canada, installation must be in accordance with the requirements of CAN/CSA B149.1, Natural Gas and Propane Installation Code.

This wall-mounted condensing gas boiler complies in its design and mode of operation with the American National Standard ANSI Z21.13/CSA4.9, latest edition for Gas-Fired Low-Pressure Steam and Hot Water Boilers.

Other confirmed approvals and certifications are indicated by labels on the boiler.

If so advised by the responsible agency, the installation must satisfy the requirements of the standard for Controls and Safety Devices for Automatically Fired Boilers, ANSI/ASME CSD-1.

Install CO detectors per local regulations. Wall-mounted gas condensing boilers require yearly maintenance (→ Chapter 15, page 65).

4.2 Operating limits of the boiler

The heat exchanger has been designed and certified in accordance with the ASME Boiler and Pressure Vessel Code, Section IV.

Maximum boiler temperature	187 °F (86 °C)
Maximum operating pressure	30 psi (2.07 bar)

Table 9 Operating limits

The hot water distribution system must comply with all applicable codes and regulations. When replacing an existing boiler, it is important to check the condition of the entire hot water distribution system to ensure safe operation.

Common practice calls for inspecting an existing system in its entirety and bringing it up to code. All pipework should be properly cleaned and flushed.

4.3 Additional regulations for installations in the Commonwealth of Massachusetts

(a) For all side wall side horizontally vented gas fueled equipment installed in every dwelling, building or structure used in whole or in part for residential purposes, including those owned or operated by the Commonwealth and where the side wall exhaust vent termination is less than seven (7) feet [2150 mm] above finished grade in the area of the venting, including but not limited to decks and porches, the following requirements shall be satisfied:

- **INSTALLATION OF CARBON MONOXIDE DETECTORS.** At the time of installation of the side wall horizontal vented gas-fueled equipment, the installing plumber or gas fitter shall ensure that a hard-wired carbon monoxide detector with an alarm and uninterruptible power supply is installed on the floor level where the gas equipment is to be installed. In addition, the installing plumber or gas fitter shall ensure that a battery-operated or hard-wired carbon monoxide detector with an alarm is installed on each additional level of the dwelling, building or structure served by the side wall horizontal vented gas-fueled equipment. It shall be the responsibility of the property owner to secure the services of qualified licensed professionals for the installation of hard-wired carbon monoxide detectors.
 - In the event that the side wall horizontally vented gas-fueled equipment is installed in a crawl space or an attic, the hard-wired carbon monoxide detector with alarm and uninterruptible power supply may be installed on the next adjacent floor level.
 - In the event that the requirements of this subsection can not be met at the time of completion of installation, the owner shall have a period of thirty (30) days to comply with the above requirements; provided, however, that during said thirty (30) day period, a battery-operated carbon monoxide detector with an alarm shall be installed.
- **APPROVED CARBON MONOXIDE DETECTORS.** Each carbon monoxide detector as required in accordance with the above provisions shall comply with NPA 720 and be ANSI/UL 2034 listed and IAS certified.
- **SIGNAGE.** A metal or plastic identification plate shall be permanently mounted to the exterior of the building at a minimum height of eight (8) feet above grade directly in line with the exhaust vent terminal for the horizontally vented gas-fueled heating appliance or equipment. The sign shall read, in print size no less than one-half (½) inch in size, “GAS VENT DIRECTLY BELOW. DO NOT BLOCK.”
- **CHECK.** The state or local gas inspector of the side wall horizontally vented gas-fueled equipment shall not approve the installation unless, upon inspections, the inspector observes carbon monoxide detectors and signage installed in accordance with the provisions of 248 CRM 5.08(2)(a) 1 through 4.

(b) EXEMPTIONS: The following equipment is exempt from 248 CRM 5.08(2)(a) 1 through 4:

- The equipment listed in Section 10 entitled “Equipment Not Required To Be Vented” in the most current edition of NFPA 54 as adopted by the board; and
- Approved side wall horizontally vented gas-fueled equipment installed in a room or structure separate from the dwelling, building or structure used in whole or in part for residential purposes.

(c) MANUFACTURER'S REQUIREMENTS - GAS EQUIPMENT VENTING SYSTEM REQUIRED. When the manufacturer of Product Approved side wall horizontally mounted gas-fueled equipment provides a venting system design or venting system components with the equipment, the instructions provided by the manufacturer for the installation of the equipment and venting shall include:

- Detailed instructions for the installation of the venting system or the venting system components; and
- a comprehensive parts list for the design and the components of the venting system.

(d) MANUFACTURER'S REQUIREMENTS – NO VENTING SYSTEM FOR GAS EQUIPMENT INCLUDED IN THE SCOPE OF DELIVERY. When the manufacturer of Product Approved side wall horizontally vented gas-fueled equipment does not provide the parts for the venting of flue gases, but identifies “special venting systems”, the following requirements shall be satisfied by the manufacturer:

- The referenced “special venting systems” shall be included with the appliance or equipment installation instructions.
- The “special venting systems” shall be Product Approved by the Board, and the instructions for that system shall include a parts list and detailed installation instructions.

(e) A copy of all instructions for all Product Approved side wall horizontally vented gas-fueled equipment, all venting instructions, all parts lists for venting instructions, and/or venting design instructions shall remain with the appliance or equipment at the completion of the installation.

5 Examples of Installations

5.1 Multiple zones using zone valves with DHW

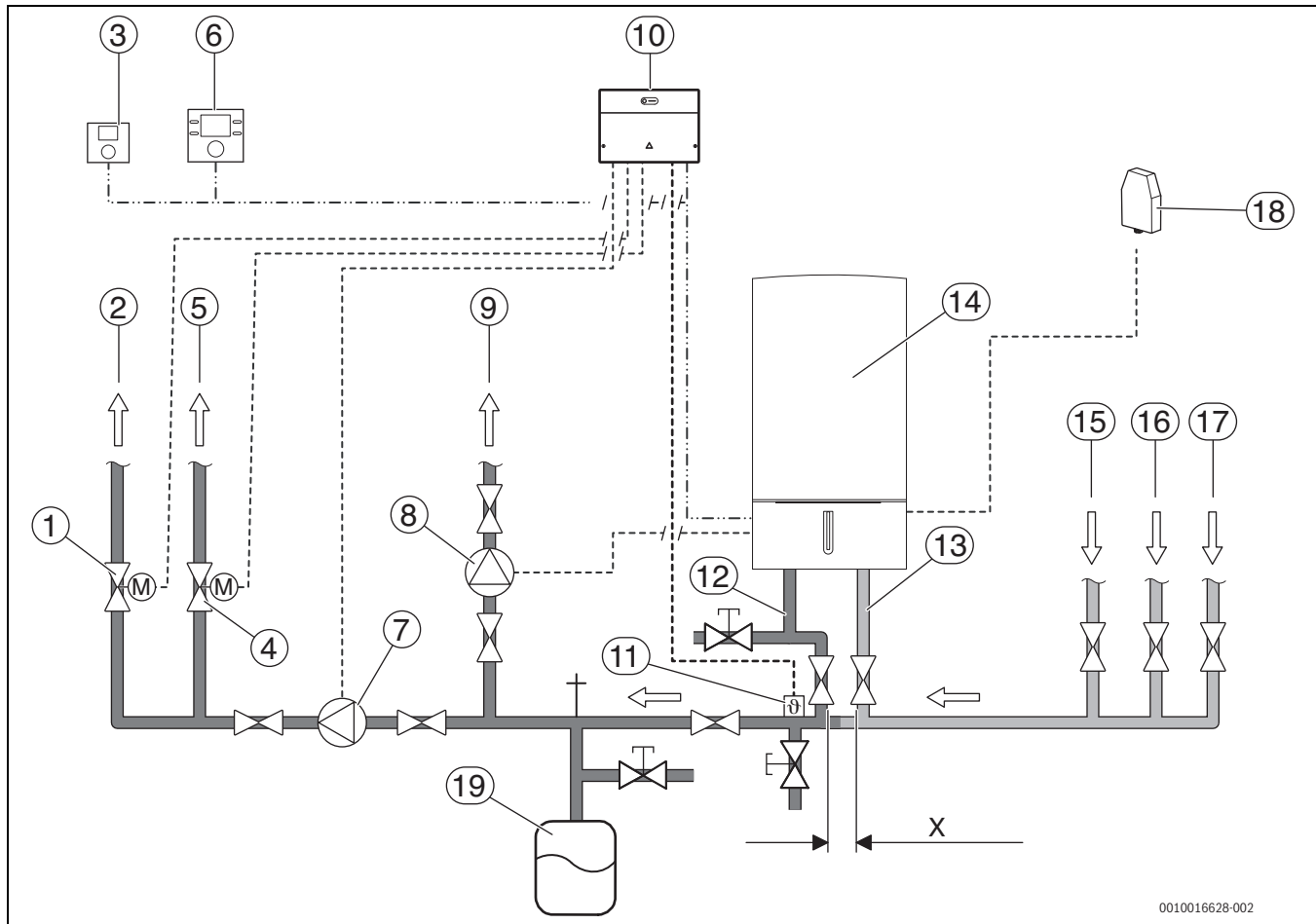

0010016628-002

Fig. 9 Piping

- [1] Motorized valve heating zone 2
- [2] To heating zone 2
- [3] Bosch room temperature controller heating zone 2 (CRC100)
- [4] Motorized valve heating zone 1
- [5] To heating zone 1
- [6] Bosch controller heating zone 1 and DHW (CRC200)
- [7] System pump
- [8] DHW pump
- [9] To indirect tank
- [10] Comfort Zone Module CZM100
- [11] External system supply temperature sensor for system supply pipe (to be installed in closest vicinity with boiler supply Tee)
- [12] Boiler primary line - supply pipe 1"
- [13] Boiler primary line - return pipe 1"
- [14] Heating boiler ZBR...-3A
- [15] From indirect tank
- [16] From heating zone 1
- [17] From heating zone 2
- [18] Outdoor temperature sensor
- [19] Expansion vessel

X ≤ 4 × pipe diameters on boiler primary side (here ≤ 4 × 1")



For all accessories not included in the package please refer to the Bosch Product Catalog.

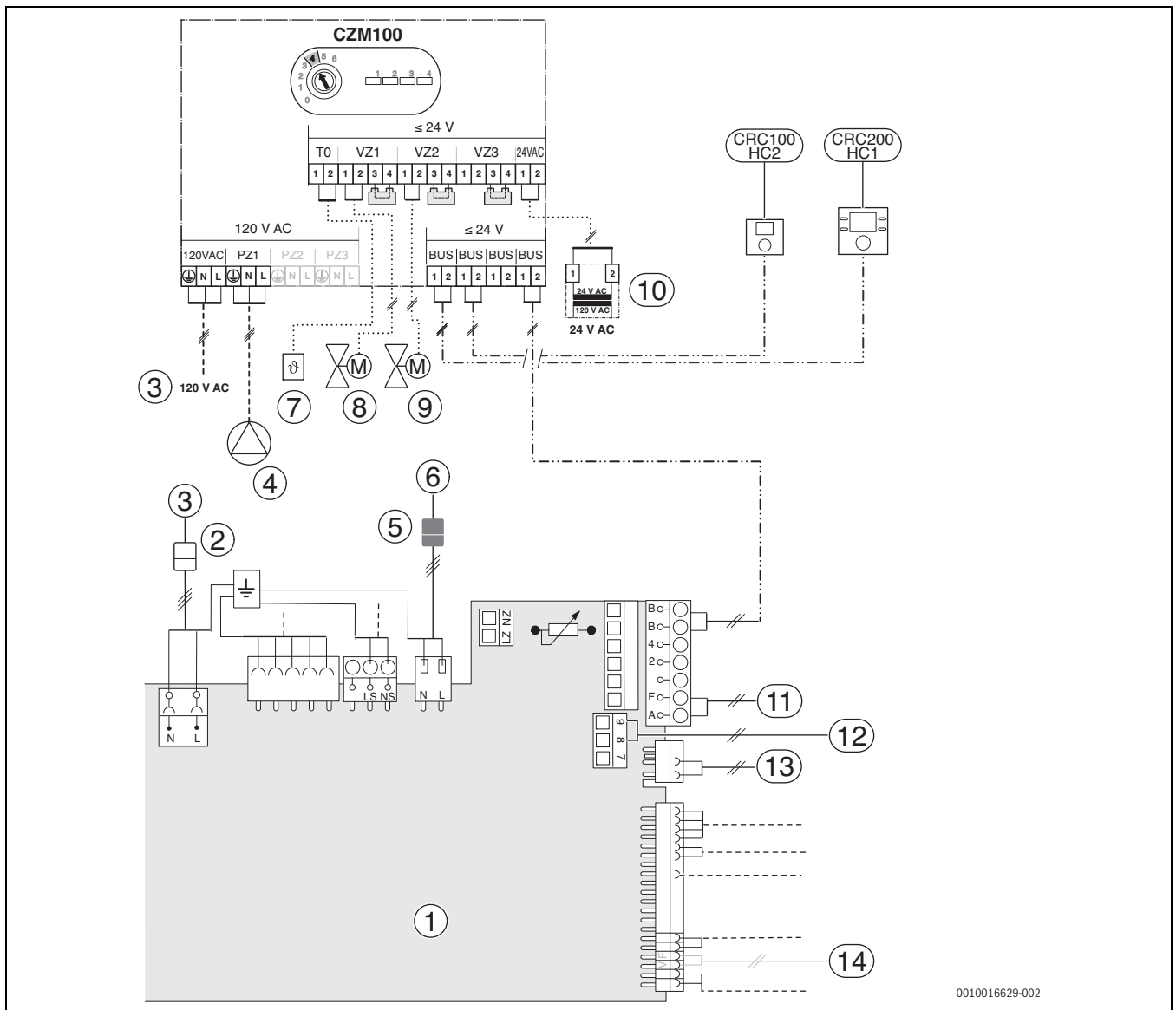

0010016629-002

Fig. 10 Wiring

- [1] PCB in heating boiler ZBR...-3A
- [2] White plug for mains power supply, 120 V AC, 60 Hz
(→ chapter 7.3.4, page 47)
- [3] 120 V AC, 60 Hz
- [4] System pump
- [5] Red plug for external DHW tank (→ chapter 7.3.3, page 47)
- [6] DHW pump
- [7] External system supply temperature sensor
- [8] Motorized valve heating zone 1
- [9] Motorized valve heating zone 2
- [10] 24 V AC transformer
- [11] Outdoor temperature sensor
- [12] LWCO (Low Water Cut Off, 24V AC Transformer required)
- [13] DHW temperature sensor (connection with clear connector)
- [14] Optionally connect external system supply temperature sensor for system supply pipe here (with white plug)



For all accessories not included in the package please refer to the Bosch Product Catalog.

5.2 Multiple zones using circulators

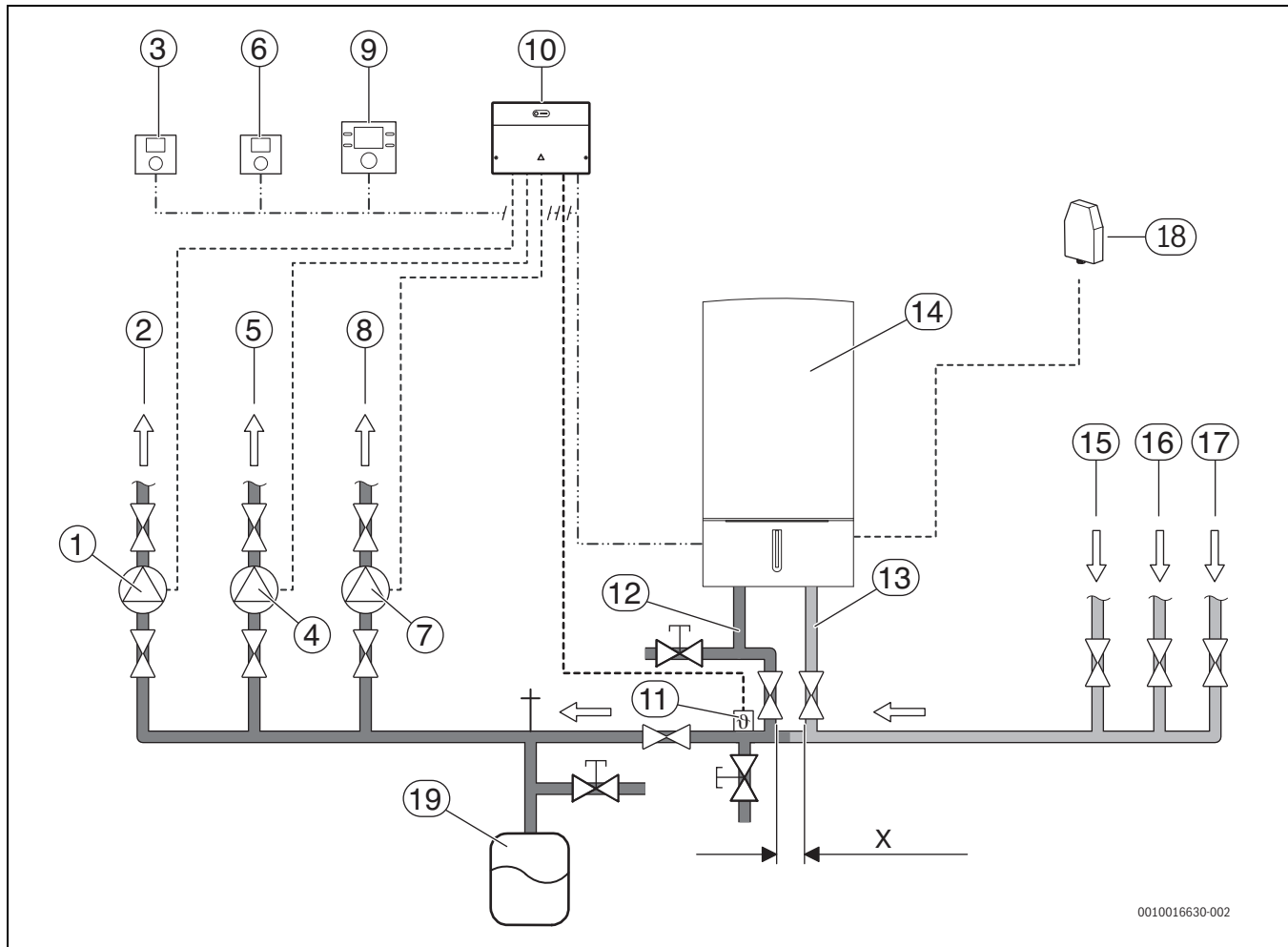

0010016630-002

Fig. 11 Piping

- [1] Pump heating zone 3
 - [2] To heating zone 3
 - [3] Bosch room temperature controller heating zone 3 (CRC100)
 - [4] Pump heating zone 2
 - [5] To heating zone 2
 - [6] Bosch room temperature controller heating zone 2 (CRC100)
 - [7] Pump heating zone 1
 - [8] To heating zone 1
 - [9] Bosch controller heating zone 1 (CRC200)
 - [10] omfort Zone Module CZM100
 - [11] External system supply temperature sensor for system supply pipe (to be installed in closest vicinity with boiler supply Tee)
 - [12] Boiler primary line - supply pipe 1"
 - [13] Boiler primary line - return pipe 1"
 - [14] Heating boiler ZBR...-3A
 - [15] From heating zone 1
 - [16] From heating zone 2
 - [17] From heating zone 3
 - [18] Outdoor temperature sensor
 - [19] Expansion vessel
- X ≤ 4 × pipe diameters on boiler primary side (here ≤ 4 × 1")



For all accessories not included in the package please refer to the Bosch Product Catalog.

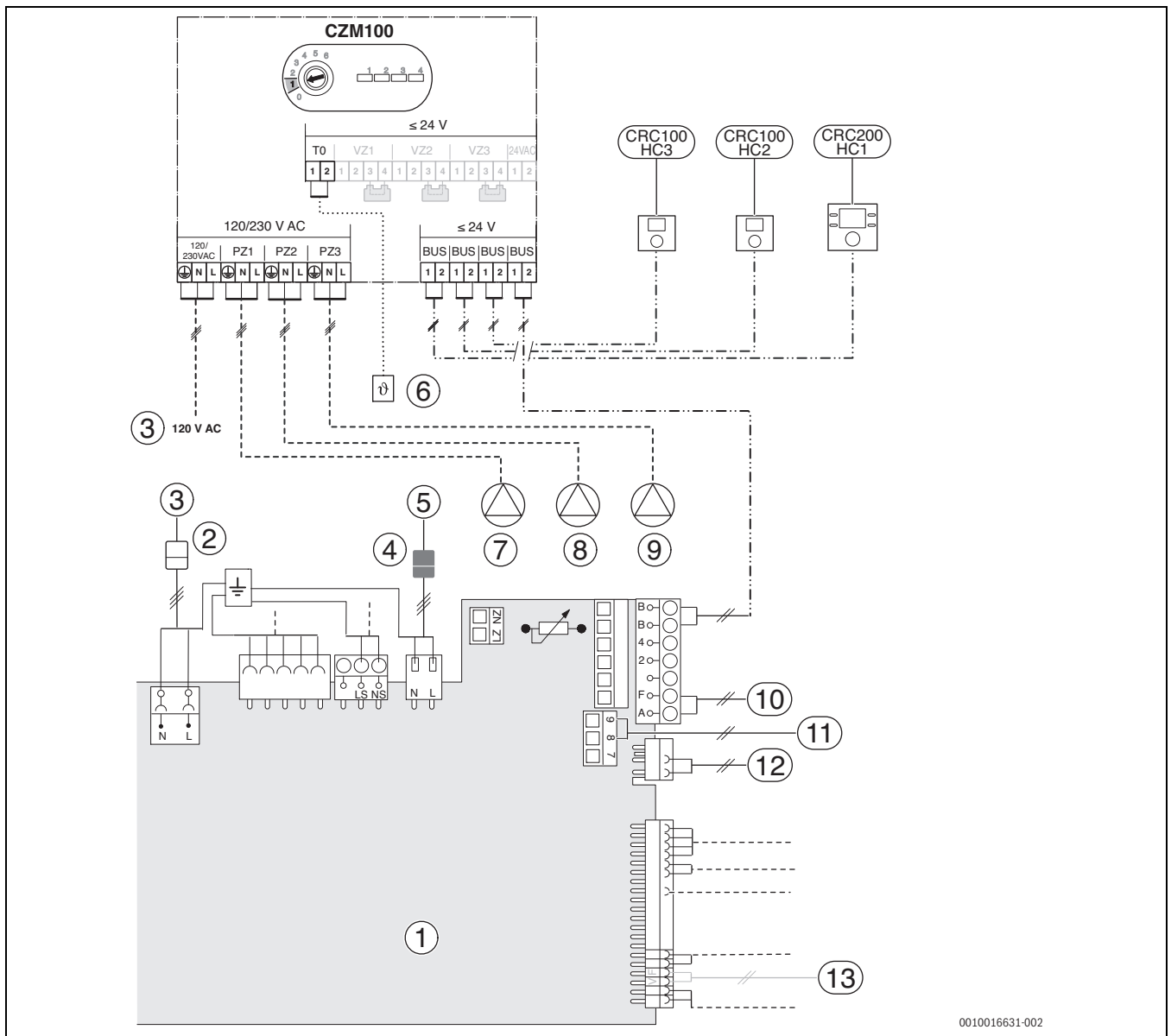

0010016631-002

Fig. 12 Wiring

- [1] PCB in heating boiler ZBR...-3A
- [2] White plug for mains power supply, 120 V AC, 60 Hz
(→ chapter 7.3.4, page 47)
- [3] 120 V AC, 60 Hz
- [4] Red plug (for external DHW tank, → chapter 7.3.3, page 47)
- [5] DHW pump
- [6] External system supply temperature sensor
- [7] Pump heating zone 1
- [8] Pump heating zone 2
- [9] Pump heating zone 3
- [10] Outdoor temperature sensor
- [11] LWCO (Low Water Cut Off, 24V AC Transformer required)
- [12] DHW temperature sensor (connection with clear connector)
- [13] Optionally connect external system supply temperature sensor
for system supply pipe here (with white plug)



For all accessories not included in the package please refer to the Bosch Product Catalog.

6 Notes on installation and operation



Explosion!

- ▶ Close the gas cock prior to working on the gas train.
- ▶ Check for gas leaks after carrying out work on the gas train.



Installation, power connection, connection on the gas and flue gas side and commissioning must only be carried out by a contractor certified for such work by the state or local jurisdiction or the local gas or power utility.

6.1 Notes on installation and operation

When installing and operating the heating system observe the following:

- The elevation of the installation location above sea level must be taken into account (→ Chapter 12.2).
- Follow all local building regulations regarding the installation conditions on site.
- The local building regulations regarding air supply and venting systems and the chimney flue connection.
- Electrical code requirements for connection to the electrical power supply.
- The technical regulations of the gas company regarding the connection of the gas burner to the local gas main.
- The regulations and standards relating to the DHW heating system.

6.1.1 Important notes

Fill and make-up water for the heating system

Unsuitable fill and make-up water can result in the heating system scaling up or failing prematurely.

Recommended steps for commissioning a new or retrofit boiler installation

- ▶ Flush the system with clean water.
- ▶ Isolate the boiler, fill the system with fresh water and a boiler cleaner, run for 30 minutes to 1 hour. Under no circumstances may boiler cleaner be pumped through the boiler.
- ▶ Thoroughly flush the system with fresh water. Ensure all zones and loops are flushed.
- ▶ Empty out sediment traps.
- ▶ Systems containing antifreeze not approved by Bosch, must be completely flushed to ensure no old fluid remains.
- ▶ Fill the system with fresh water and the proper amount of inhibitor.
- ▶ Verify the pH is within the proper range.
- ▶ Add additional inhibitor if pH is not within the proper range.
- ▶ Check pH annually.
- ▶ If using antifreeze, fill with approved antifreeze and fresh water.
- ▶ Always follow the cleaner, antifreeze, or additive manufacturer's instructions.
- ▶ Do not mix different manufacturer's products
- ▶ Follow manufacturer's data to determine the anti-freeze ratio for the desired freeze protection temperature.

Recirculation pump/DHW recirculation lines

Total length DHW/recirculation line	Flow rate
≤ 33 ft (10 m)	0.66 gpm (2.5 l/min)
33 - 66 ft (10 - 20 m)	0.92 gpm (3.5 l/min)
66 - 98 ft (20 - 30 m)	1.32 gpm (5 l/min)

Table 10 Recommended flow rates



Use service function **6.d**, to determine the current flow rate (→ page 60).

Electrical connection of the DHW recirculation pump (→ page 46).

Connect the DHW recirculation line with the cold water inlet as close as possible to the Hydraulics connection plate.

Open vented heating systems

- ▶ Convert open vented heating systems into closed systems.

Gravity heating systems

- ▶ Connect the appliance to the existing piping system via a low-loss header with a sludge separator.

Galvanized radiators or pipes.

To prevent gas formation:

- ▶ Do not use galvanized radiators or pipes.

Plastic pipework

If using plastic pipework for the heating system (eg. underfloor/radiant heating), the type of pipe that should be used must be oxygen tight.

Use of a room temperature controller

- ▶ Do not install thermostatic valves on radiators in the primary room.

Primary-secondary piping or a low loss header

In the case of radiant floor heating, panel radiators, systems with several heating zones or 3/4" baseboard heating (≥ 70 ft (21 m), temperature difference ≥ 20 °F (11 °C), flow rate ≥ 4.0 gpm (15.1 L/min) plus the required supply and return pipes), hydraulic separation of the system is required, e. g. by means of a low-loss header.

Anti-freeze

NOTICE

Insufficient antifreeze can accelerate corrosion.

- ▶ Follow manufacturer's instructions on antifreeze concentration.
- ▶ Frost protection level has to be checked annually during the regular scheduled maintenance of the condensing boiler.

NOTICE

System damage!

- ▶ It is the installer's responsibility to ensure that the heating system is compatible with the boiler type and size installed.
- ▶ pH-value of the heating water to be kept between 7 and 8.5.

The following anti-freeze fluids and concentrations have been approved:

Chemical Name	Concentration
Nalco (Varidos) FSK	22 - 55 %
Fernox Alphi 11	Observe manufacturer's instructions
Intercool NFP-50 AA	0 - 39 %
Antifrogen N	Observe manufacturer's instructions
NoBurst AL	0 - 55 %

Table 11 Anti-freeze

Corrosion inhibitors

The following anti-corrosion agents are approved:

Chemical Name	Concentration
Fernox F1	Observe manufacturer's instructions
Nalco 77381	1 - 2 %
Sentinel X 100	1.1 %

Table 12 Corrosion inhibitors

- ▶ System fluid pH must be maintained between 7 and 8.5 to prevent system damage.
- ▶ Use only untreated water to fill the system.
- ▶ Do not use TSP (tri-sodium phosphate).
- ▶ Do not use fill water treated with salt bedding type exchangers (ion exchanger).
- ▶ Never introduce non-approved boiler treatment or similar additives.
- ▶ Only use fill water with a hardness below 7 grains.
- ▶ Filling with chlorinated water is acceptable if chlorine levels are below 100 ppm.
- ▶ Do not use inhibitors or other additives unless listed in this document.
- ▶ Consult a local water treatment specialist for recommendations if any of the above is outside the stated ranges.
- ▶ When using oxygen permeable PEX, the system must be separated from the boiler by a heat exchanger.
- ▶ A correctly sized and working expansion vessel must be installed.
- ▶ Do not exceed the maximum permissible flow rate through the boiler. Excessive flow can cause erosion damage to the heat exchanger.
- ▶ **Eliminate leaks in the system**
Continually topping up the system constantly adds oxygen to the heating water, causing corrosion damage. All system leaks must be repaired.

Boiler sealer

This boiler is not approved for use with boiler sealer.

LPG

To protect the appliance against high pressure (ANSI/Z223.1/NFPA54 (National fuel gas code) or CAN/CSA B 149.1 (Natural Gas and Propane installation code)):

- ▶ Install a pressure regulator with a safety valve.

6.1.2 Other important information

- The installation of this boiler must comply with all national and local code and regulations.
- Only operate this boiler with the combined air/flue system specifically designed and approved for it.
- Use only approved venting systems per the manufacturer's instructions.
- Do not dispose of untreated boiler condensate in septic systems.
- Inspect the sewer pipes for suitability before disposing of untreated boiler condensate in them.
- Verify with the local authority that disposing of untreated boiler condensate into public sewer systems is permitted.

6.1.3 Water Supply Pressure

The connection pressure of the water supply must be between 4.35 psi and 150 psi.

- ▶ If necessary, install a pressure reducing valve.



For optimum performance it is recommended to keep pressure between 20 to 30 psi.

NOTICE

Damage due to overpressure.

Non-return, backflow prevention devices (including those associated with water meters) fitted to the incoming water supply can cause a pressure build up which could damage the boiler and other household appliances.

- ▶ Where the incoming water supply has a non-return, backflow prevention valve installed, a mini expansion vessel should be connected to the water supply pipe between the non-return valve and the boiler.

6.2 Comparing the size of the integrated expansion vessel

The following diagrams allow verifying that the integrated expansion vessel has sufficient capacity for the intended application, or if an additional expansion vessel is needed (not for radiant floor heating).

The following standard conditions were used:

- Precharge volume 20% of the rated volume in the expansion vessel
- Differential to the safety valve of 7.25 psi (0.5 bar)
- Precharge pressure of the expansion vessel equal to the static system height above the boiler
- Maximum operating pressure: 30 psi (2.07 bar)

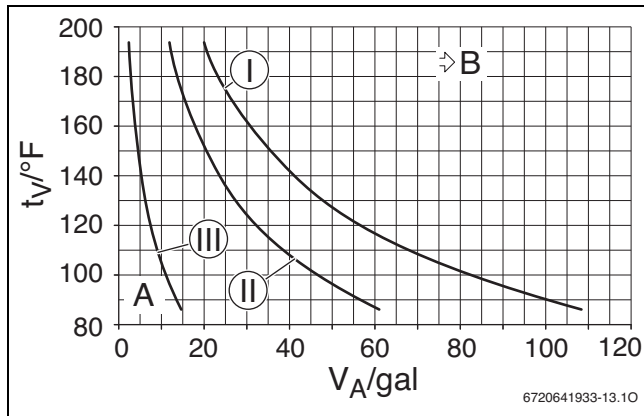

Fig. 13 Operating capacity of the expansion vessel in °F and gallons

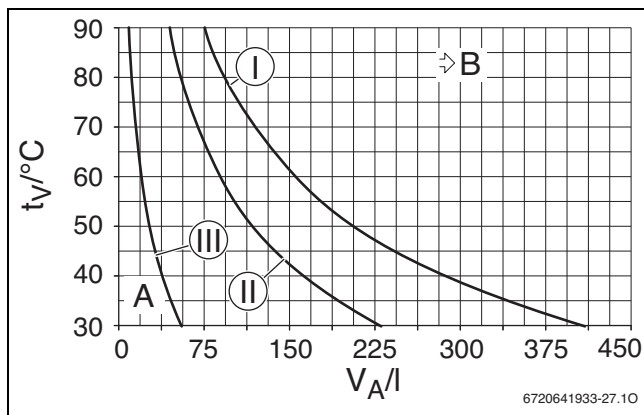

Fig. 14 Operating capacity of the expansion vessel in °C and liters

Key to Fig. 13 and Fig. 14:

- [I] Precharge pressure 7.25 psi (0.5 bar) (default setting)
 - [II] Precharge pressure 10.9 psi (0.75 bar)
 - [III] Precharge pressure 14.5 psi (1.0 bar)
 - t_V Supply temperature in °F (°C)
 - V_A System capacity in gallons (liters)
 - A Within operating capacity of the expansion vessel (left of the relevant curve)
 - B Additional expansion vessel required (right of the relevant curve)
- ▶ If results are borderline: Determine precise vessel sizes.
 - ▶ If the results are to the right of the curve: Install additional expansion vessel.

6.3 Selecting an external expansion vessel (ZBR...-3A)

- ▶ Determine the size of the expansion vessel in compliance with local laws and regulations.

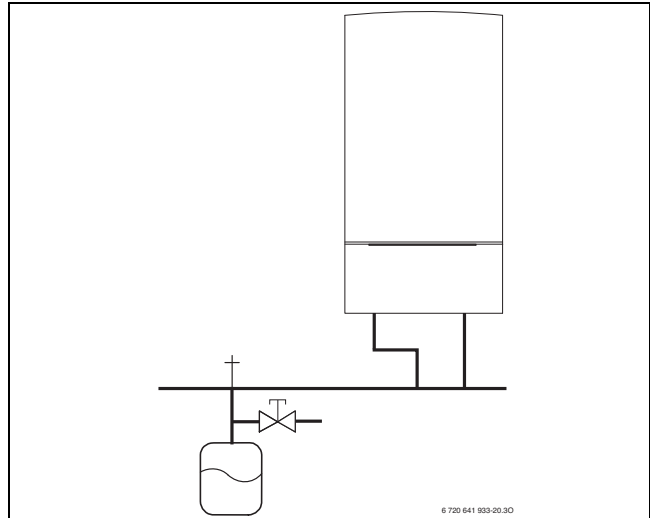

Fig. 15 Example of installation of an external expansion vessel

6.4 Selecting the installation location

Installation location requirements

Observe the current national and local codes and regulations.

- ▶ Observe country-specific requirements.
- ▶ Observe installation instructions of the venting system accessories and their clearances.

Combustion air

To avoid corrosion, keep the supply of combustion air free of corrosive substances; contained in solvents, paints, adhesives, propellants and domestic cleaning agents.

Industrial sources	
Chemical cleaning	Trichloroethylene, tetrachloroethylene, fluorinated hydrocarbons
Degreasing bath	Perchloroethylene, trichloroethylene, methylchloroform
Printing shops	Trichloroethylene
Hair salons	Aerosol propellants, hydrocarbons containing fluorine and chlorine (difluorodichloromethane)
Household sources	
Cleaning and degreasing agents	Perchloroethylene, methylchloroform, trichloroethylene, methylene chloride, carbon tetrachloride, hydrochloric acid
Workshop	
Solvents and thinners	Various chlorinated hydrocarbons
Aerosols	Chlorofluorinated hydrocarbons (difluorodichloromethane)

Table 13 Corrosive materials

Surface temperature

The max. surface temperature of this appliance is below 185 °F (85 °C). According to ANSI/Z223.1/NFPA54 (National fuel gas code) and CAN/CGA B 149.1 (Natural Gas and Propane installation code), the appliance is approved for zero clearance to combustibles. For servicing a clearance of 4" (102 mm) is recommended.

6.5 Pre-installing pipes

- ▶ Secure the installation template (supplied with the technical documentation) to the wall; observe the minimum side clearances of 4 inches (102 mm) (→ page 4).
- ▶ Drill holes for the appliance and for the hydraulics connection plate in accordance with the mounting template.

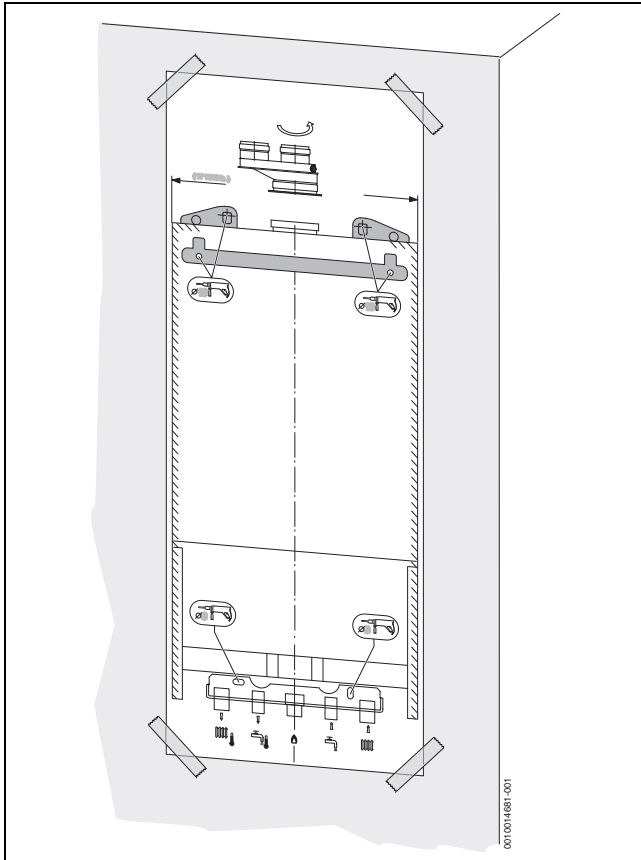

Fig. 16 Mounting template

NOTICE

For walls with insufficient load capacity, the appliance and the hydraulics connection plate must be mounted on a sheet of plywood or similar reinforcement.

- ▶ Remove the mounting template.

- ▶ Secure the hydraulics connection plate and the mounting bracket with the mounting kits supplied.

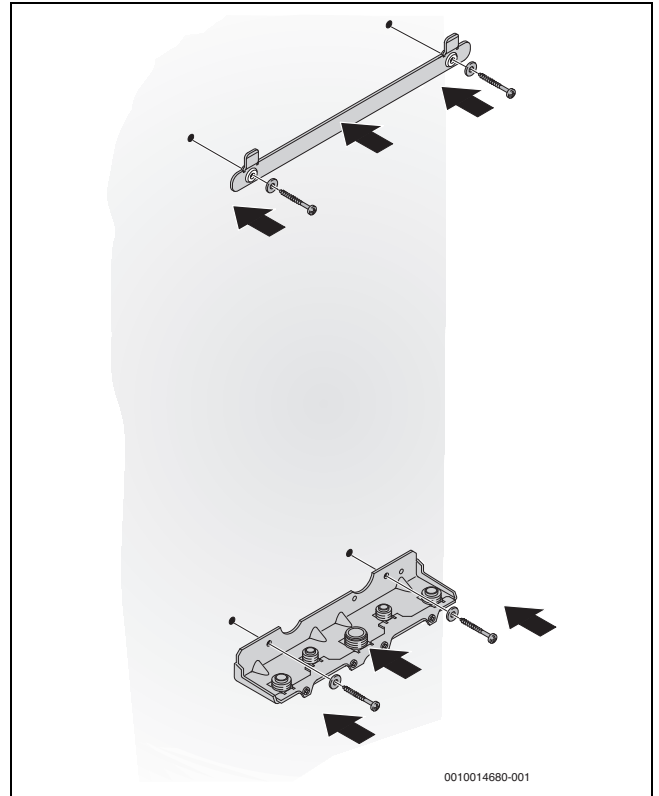

Fig. 17 Mounting of the hydraulics connection plate and the mounting bracket

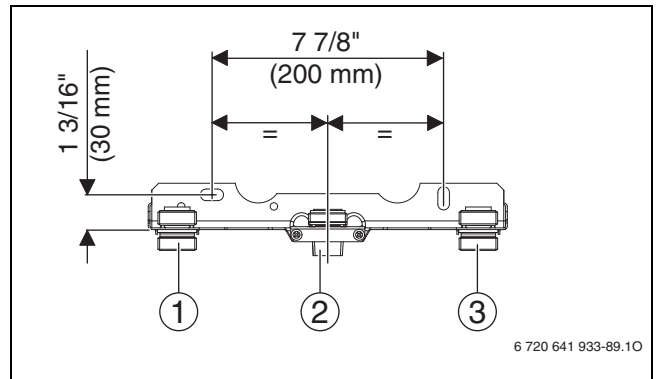

Fig. 18 Hydraulics connection plate for heating boiler ZBR...-3A (front view)

- [1] Heating supply, 1" NPT
- [2] Gas, 3/4" NPT
- [3] Heating return, 1" NPT

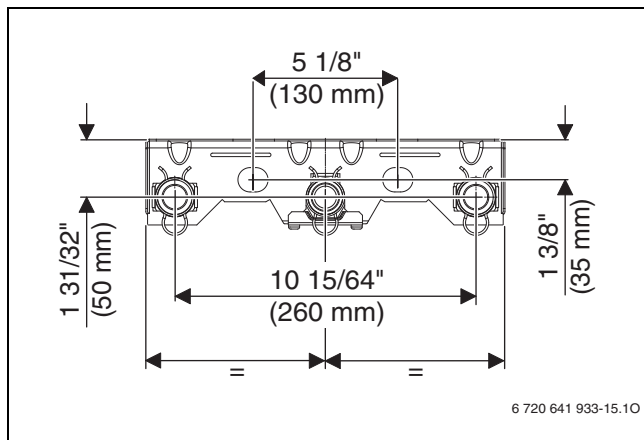

Fig. 19 Hydraulics connection plate for heating boiler ZBR...-3A (top view)

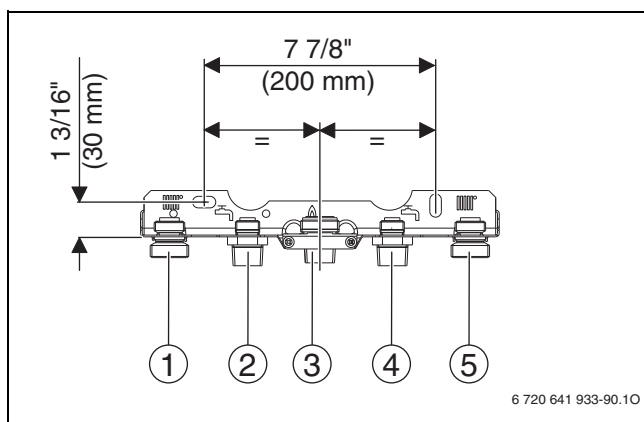

Fig. 20 Hydraulics connection plate for combi boiler ZWB...-3A (front view)

- [1] Heating supply, 1" NPT
- [2] DHW, 3/4" NPT
- [3] Gas, 3/4" NPT
- [4] Cold water, 3/4" NPT
- [5] Heating return, 1" NPT

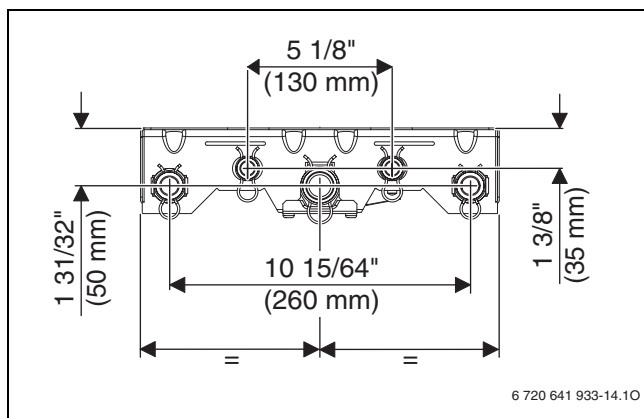

Fig. 21 Hydraulics connection plate for combi boiler ZWB...-3A (top view)

- ▶ Determine pipe size for the gas supply.
- ▶ To fill and drain the system, install a fill and drain valve at the lowest point.

6.6 Mounting the appliance

NOTICE

Residue, metal shavings, and contaminants in the piping can damage the appliance.

- ▶ Flush the piping thoroughly and completely to remove all residue.
- ▶ Follow the instructions with respect to water quality (→ Chapter 6.1.1, page 28).

- ▶ Remove packaging, observing all notes and symbols.
- ▶ On the type plate, check the identification of the target country and suitability for the gas type supplied by the local gas utility company (→ page 6).

Removing the cover



The cover is secured with two screws against unintentional removal (electrical safety).

- ▶ Always keep the cover secured with these screws.
- ▶ Undo screws (step 1).
- ▶ Lift strap (step 2) and remove cover toward the front (step 3).

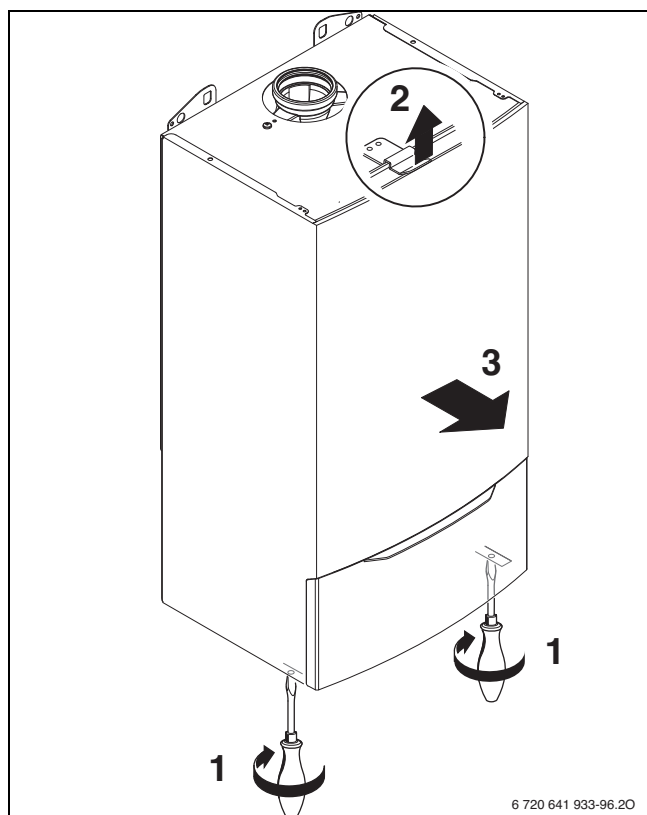

Fig. 22 Remove the cover

Hanging the appliance

- ▶ Check that the gas type matches (→ data plate).
- ▶ Remove the transport brackets.
- ▶ Place the gaskets on the pipe connections.
- ▶ Hang the appliance.
- ▶ Check the positioning of the gaskets on the pipe connections.
- ▶ Tighten the union nuts on the pipe connections.

6.7 Installing the low water cut off (LWCO)

The boiler is equipped with a dedicated port for installation of a LWCO on the supply pipe inside the boiler cabinet. This location represents the minimum water level for safe operation of the boiler.

The LWCO device must be specified for an ambient temperature of 176 °F (80 °C) and a water temperature of 250 °F (121 °C). It needs a dry contact.

The following LWCO is approved with the boiler:

- Hydrolevel Safgard 1100

The device is available at most Bosch wholesalers. It requires an external 24VAC AC 20VA transformer provided on site.



When a different LWCO is used, it must be installed outside the wall-mounted gas condensing boiler.

The Hydrolevel Safgard 1100 is installed in the supply pipe to the left of the heat exchanger.

- ▶ Disconnect the boiler from power by shutting off the emergency shutoff switch or disengaging the heating system circuit breaker.
- ▶ Drain the boiler.
- ▶ Remove the safety clip from the dummy plug in the supply pipe (step 1).
- ▶ Pull off the dummy plug (step 2) and place with the boiler documentation.
- ▶ Ensure the O-ring remains in place on the pipe.
- ▶ Lubricate the O-ring.

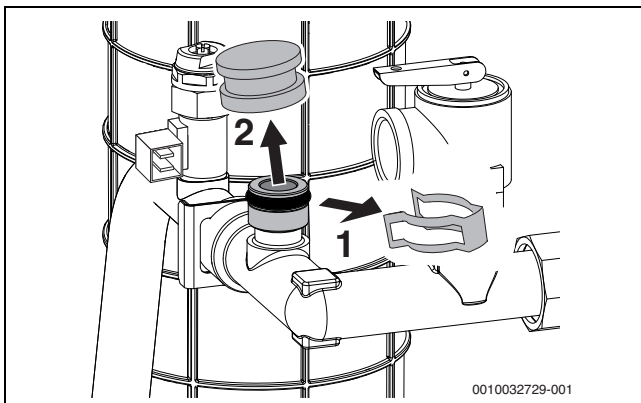

Fig. 23 Installing a LWCO device - removing dummy plug

- ▶ Screw the LWCO as far as possible into LWCO adapter located in the boiler accessory kit. Follow the Hydrolevel Safgard 1100 instructions.

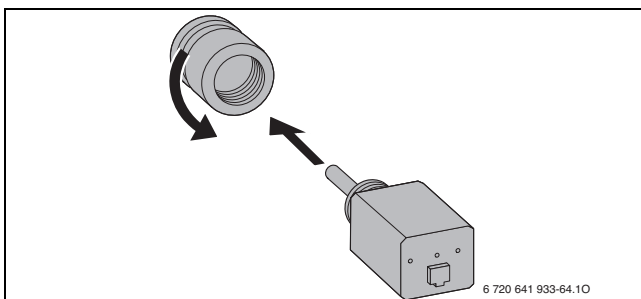

Fig. 24 Installing a LWCO device - LWCO adapter

- ▶ Push the adapter with the LWCO onto the pipe (step 1) and secure with the clip (step 2).

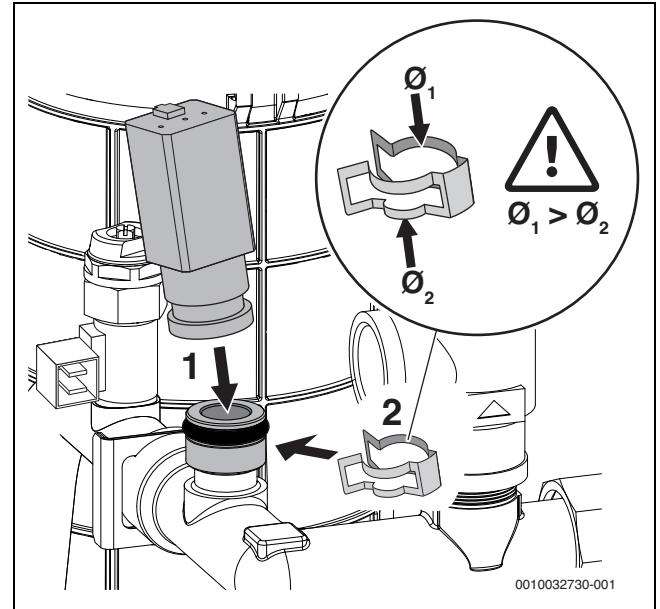

Fig. 25 Installing a LWCO device securing with a clip

- ▶ Connect the wires of the LWCO (→ chapter 48, page 7.4).



The LWCO is positioned upright for technical reasons. Tests have shown that all air will be bled from the pipe during commissioning and full functionality is established.



If fault **d3** is displayed when commissioning the boiler, purge the boiler properly and check the boiler water pressure.

6.8 Connecting flue gas accessories

Optional vent systems are:

- Twin pipe PVC / CPVC 2" / 3"
- Twin pipe PP 2" (50 mm) / 3" (80 mm) (M&G Duravent PolyPro and Centrotherm InnoFlue)
- Concentric PP 3" / 5" (80/125 mm) (Bosch)

In case of using the **twin pipe adaptor**:



The twin pipe adaptor is supplied with the boiler kit as standard and is certified as a part of the vent system.

- Install the vent flange and gasket with the screws enclosed.

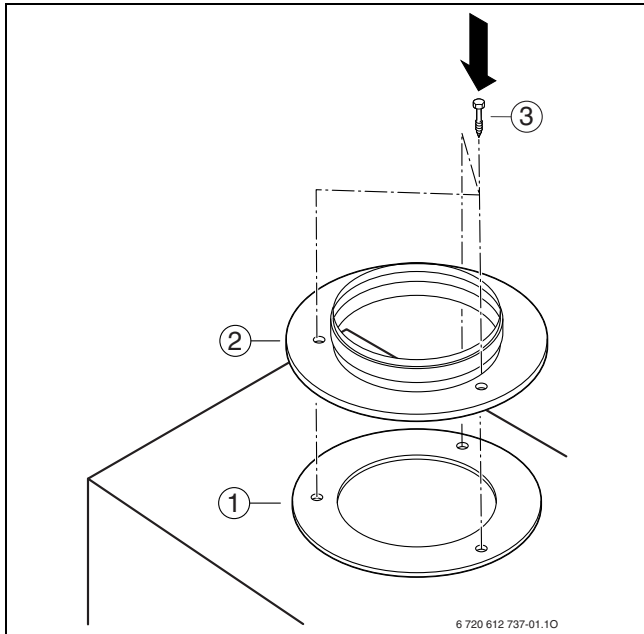

Fig. 26 Attaching the vent flange and gasket

- [1] Gasket
- [2] Vent flange
- [3] Screws

- Insert the flue gas adapter as far as it will go into the vent flange and align it.

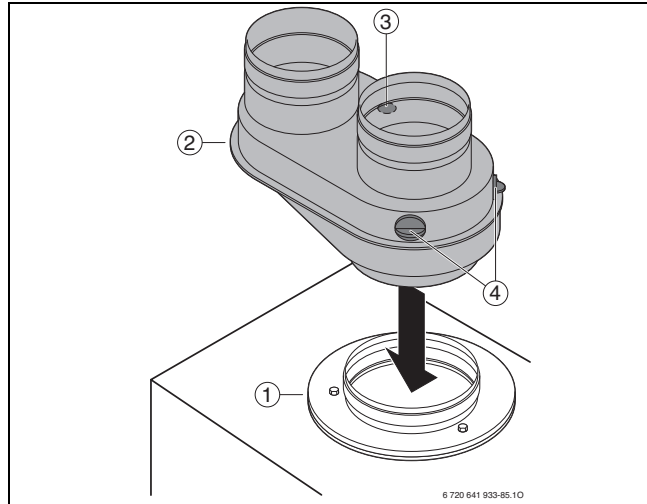

Fig. 27 Flue gas adapter

- [1] Vent flange
- [2] Flue gas adapter
- [3] Combustion air test port
- [4] Flue gas test ports

- Tighten the screws.



To avoid premature wear of the gaskets DO NOT use lubricants.

In case of **open venting**:

- Use basket on the air intake.

In case of **concentric venting system**:



As an alternative to twin pipe venting, a purposely designed and built telescopic concentric vent kit can be obtained as an accessory from Bosch Thermotechnology for a horizontal direct vent wall termination. This vent system can be used for vent lengths of 2 feet to 3 feet (610 mm to 915 mm).

For more details on connecting the flue system, refer to the installation instructions for the flue kit.

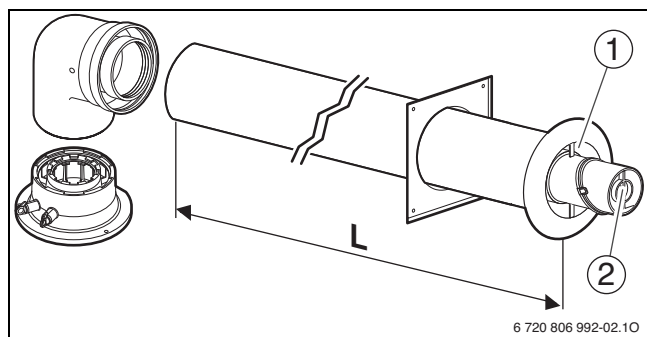

Fig. 28 Horizontal venting system (telescopic concentric vent kit)

- [1] Intake
- [2] Exhaust
- L 2 feet to 3 feet (610 mm to 915 mm)

- ▶ Install the concentric vent adaptor with the screws enclosed.

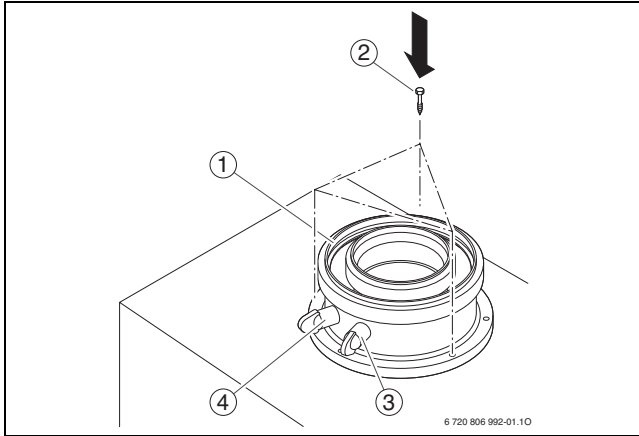

Fig. 29 Installing the concentric vent adaptor

- [1] Concentric vent adaptor
- [2] Screws
- [3] Combustion air test port
- [4] Flue gas test port

For atmospheric combustion, the supply air connection must be provided with a safety mesh.

6.8.1 Installation of the exhaust and air intake system

NOTICE

- ▶ Vent connectors serving appliances vented by natural draft shall not be connected to any portion of mechanical draft systems operating under positive pressure.

NOTICE

Burner damage!

- ▶ Avoid drawing in combustion air excessively loaded with dust or airborne particles.

! DANGER

- ▶ Ensure that the flue pipes and seals are not damaged.
- ▶ Use only sealing compounds (primer and glue) approved with the vent material.
- ▶ Never install a barometric nor a thermally controlled vent damper with this boiler.
- ▶ Connect only one boiler to each flue system or chimney flue.
- ▶ Do not route the flue system piping through or inside another duct that is used for exhausting air or other flue gases.
- ▶ The condensate trap must be primed at all times. Failure to do so may allow combustion gases to escape into boiler room.
- ▶ External insulation on plastic vent pipe is prohibited.

i

Consult local and state codes pertaining to special building code and fire department requirements. Adhere to national code requirements.

i

Observe the listed maximum lengths of vent system, which are boiler model dependent (→ chapter 6.8.3).

! DANGER

Improper venting of the Greenstar boiler can result in excessive levels of carbon monoxide which can result in severe personal injury or death.

- ▶ The boiler must be vented in accordance with the Venting of Equipment section of the latest edition of ANSI Z 223.1 / NFPA 54 Natural Fuel Gas Code and/or the Venting systems and air supply for appliances section of the latest version of CAN/CGA B149.1 Natural Gas and Propane Installation Code in Canada and in accordance with all applicable local building codes.

NOTICE

- ▶ To prevent moisture and frost and ensure the minimum clearances to openings and neighboring buildings, 45° and 90° elbows or T-pieces may be attached to the flue outlet in order to direct flue gas away from neighboring buildings. The total allowable vent length, maximum number of elbows and distance to air intake restrictions must be adhered to.

Optional vent systems are:

- Direct vent installations (sealed combustion)

Direct vent installations (sealed combustion)

For direct vent applications all applicable items below must be met.

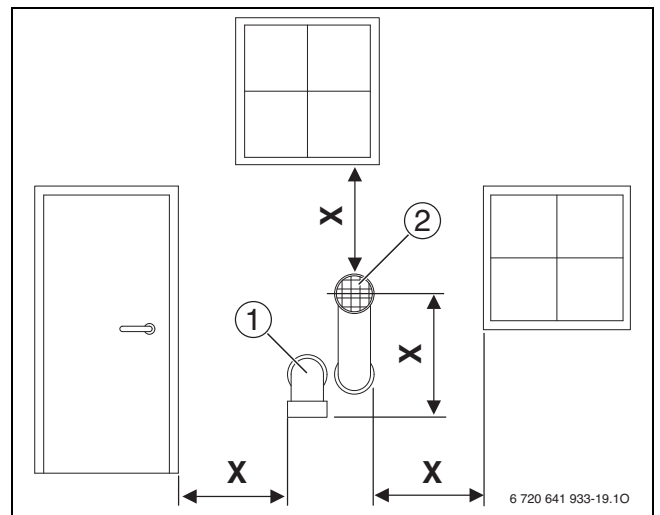

Fig. 30 Vent and combustion air pipe position of a sealed combustion system

- [1] Intake
- [2] Exhaust
- X At least 1 foot (305 mm)

Vent termination must be at least 1 foot (305 mm) below, 1 foot (305 mm) horizontally away from or 1 foot (305 mm) above every door, every window or every air opening in any building (→ Fig. 31 [2], [X₁], [X₃], page 31).

If multiple boilers are installed in a row, allow at least 1 foot (305 mm) clearance between the vent termination of one and the combustion air intake of the other.

The combustion air inlet is located at least 1 ft (305 mm) above the upper edge, the expected snow line or roof surface (in Canada, at least 1 1/2 ft (457 mm) (→ Fig. 31 [Y_A], page 31).

Vent termination must be located at least 7 ft (2135 mm) above public traffic routes (→ fig. 31 [X₅], page 31). Condensate can exit at the terminal end. Ensure that condensate spilling from the termination does not create a hazard or a nuisance.

Do not allow exposed vent pipes outside the building to extend past the recommended distance. Condensate can freeze and block the flue outlet.

Vent termination must be at least 3 ft (915 mm) away from adjoining walls, inside corners and 5 ft (525 mm) below the roof overhang (→ Fig. 31 [X₂], [X₄], page 31).

Do not extend exposed vent pipe outside the building beyond recommended distance. Condensate could freeze and block vent pipe.

Do not use the chimney as a conduit if the flue gases from a wall-mounted gas condensing boiler or other combustion equipment are routed in or through the chimney.

All non-steel PVC/CPVC vent pipes must be glued, except for the flue gas adapter.



The flue pipe must be supported properly and angled downward at least ¼ inch (6.35 mm) per foot from the wall-mounted gas condensing boiler. This allows the condensate to drain away.

NOTICE

Damage of 2 inch PVC pipes.

- ▶ For ZBR 42-3 A and ZWB 42-3 A use 2 inch CPVC-pipes or 3 inch pipes.

All PP/PVC/CPVC combustion air and vent pipe materials and fittings must be approved and comply with the following:

Material	Item	United states	Canada	ZBR 21-3 A	ZBR 28-3 A	ZBR 35-3 A	ZBR 42-3 A	ZWB 28-3 A	ZWB 35-3 A	ZWB 42-3 A
PVC schedule 40, 80	2" (50 mm) Vent or air pipe and fitting	ANSI/ASTM D1785 or UL 1738	BH Gas venting systems, ULC S636 ^a , Class IIA - PVC, Class IIB - CPVC, Class IIC - Polypropylene (certified to ULC S636)	X	X	X		X	X	
PVC-DWV		ANSI/ASTM D2665 or UL 1738		X	X	X		X	X	
CPVC schedule 40, 80		ANSI/ASTM F441 or UL 1738		X	X	X	X	X	X	X
PVC schedule 40, 80	3" (76 mm) Vent or air pipe and fitting	ANSI/ASTM D1785 or UL 1738		X	X	X	X	X	X	X
PVC-DWV		ANSI/ASTM D2665 or UL 1738		X	X	X	X	X	X	X
CPVC schedule 40, 80		ANSI/ASTM F441 or UL 1738		X	X	X	X	X	X	X
PP rigid venting	3" (80 mm) vent or air pipe M&G Duravent PolyPro and Centrotherm InnoFlue	ANSI Cat IV Approved Polypropylene		X	X	X	X	X	X	X
PP rigid venting	2" (50 mm) vent or air pipe M&G Duravent PolyPro and Centrotherm InnoFlue	ANSI Cat IV Approved Polypropylene		X	X	X	X	X	X	X
PP rigid venting	3"/5" (80/125 mm) concentric (Bosch, manufactured by M&G Duravent)	ANSI Cat IV Approved Polypropylene		X	X	X	X	X	X	X
PP-Flex	3" (80 mm) vent or air pipe M&G Duravent PolyPro and Centrotherm InnoFlue	ANSI Cat IV Approved Polypropylene	BH Gas venting systems, ULC S636 ^a , Class IIA - PVC, Class IIB - CPVC, Class IIC - Polypropylene (certified to ULC S636)	X	X	X	X	X	X	X
PP-Flex	2" (50 mm) vent or air pipe M&G Duravent PolyPro and Centrotherm InnoFlue	ANSI Cat IV Approved Polypropylene		X	X	X		X	X	
PVC	Pipe cement/primer	ANSI/ASTM D2564		X	X	X	X	X	X	X
CPVC		ANSI/ASTM F493		X	X	X	X	X	X	X

a. Components of the certified vent systems must not be interchanged with other vent systems or unlisted pipe fittings. Plastic components, and specified primers and glues of the certified vent system must be from a single system manufacturer and not intermixed with other system manufacturer's vent system parts.

Table 14 Materials for pipe

For installations in Canada, field supplied plastic vent piping must comply with CAN/CGA B149.1 (latest edition) and be certified to the Standard for Type BH Gas Venting systems. ULC S636 components of the listed system may not be combined with other venting systems or pipes/fittings that are not listed here. All plastic components and

specified primers and glues of certified vent systems must be from a single manufacturer and not intermingled with other system manufacturer's vent system parts. The supplied vent connector and separate available vent termination are certified as a part of the Greenstar Boiler.

Roof terminals	Material	Supplier	Part number
Ø 3"/5" (Ø 76/125 mm)	concentric PVC	IPEX System 636	196006
Ø 3"/5" (Ø 76/125 mm)	concentric CPVC	IPEX System 636	197009
Ø 3"/5" (Ø 80/125 mm)	concentric PP	M&G Duravent PolyPro and Centrotherm InnoFlue	3PPS-VK (-TC) (M&G Duravent) or ICRT3539 (Centrotherm)
Ø 3" (Ø 80 mm)	PolyPro Flex Chimney Cap (PP)	M&G Duravent PolyPro Centrotherm InnoFlue	3PPS-FCT ISCP03
with base support	PolyPro Support Elbow Base Support + SW to Flex Coupler	M&G Duravent PolyPro Centrotherm InnoFlue	3PPS-SE90X ISBS0387 + IFSFC03
Ø 2" (Ø 50 mm)	PolyPro Flex Chimney Cap (PP)	M&G Duravent PolyPro Centrotherm InnoFlue	2PPS-FCT ISCP02
with base support	PolyPro Support Elbow Base Support + SW to Flex Coupler	M&G Duravent PolyPro Centrotherm InnoFlue	2PPS-SE90X ISBS0287 + IFSFC02

Table 15 Roof terminals

Wall terminals	Flue System / Materials	Supplier	Part number
Ø 3" (Ø 76 mm)	parallel stainless steel	Flex-L	46546901
90°-elbow with inlet screen	PVC (elbow) stainless steel (screen)	IPEX (elbow) Langly Wire (screen)	ULC S636 approval (elbow) L2594 (screen)
Ø 3" (Ø 76 mm) twin pipe termination	PP	M&G Duravent PolyPro	3PPS-HTP
Ø 3" (Ø 76 mm) single pipe termination	PP	M&G Duravent PolyPro	3PPS-HST
Ø 3"/5" (Ø 80/125 mm) Bosch Greenstar Horizontal Telescopic Terminal Kit	PP	Bosch (manufactured by M&G Duravent)	7738003218

Table 16 Wall terminals

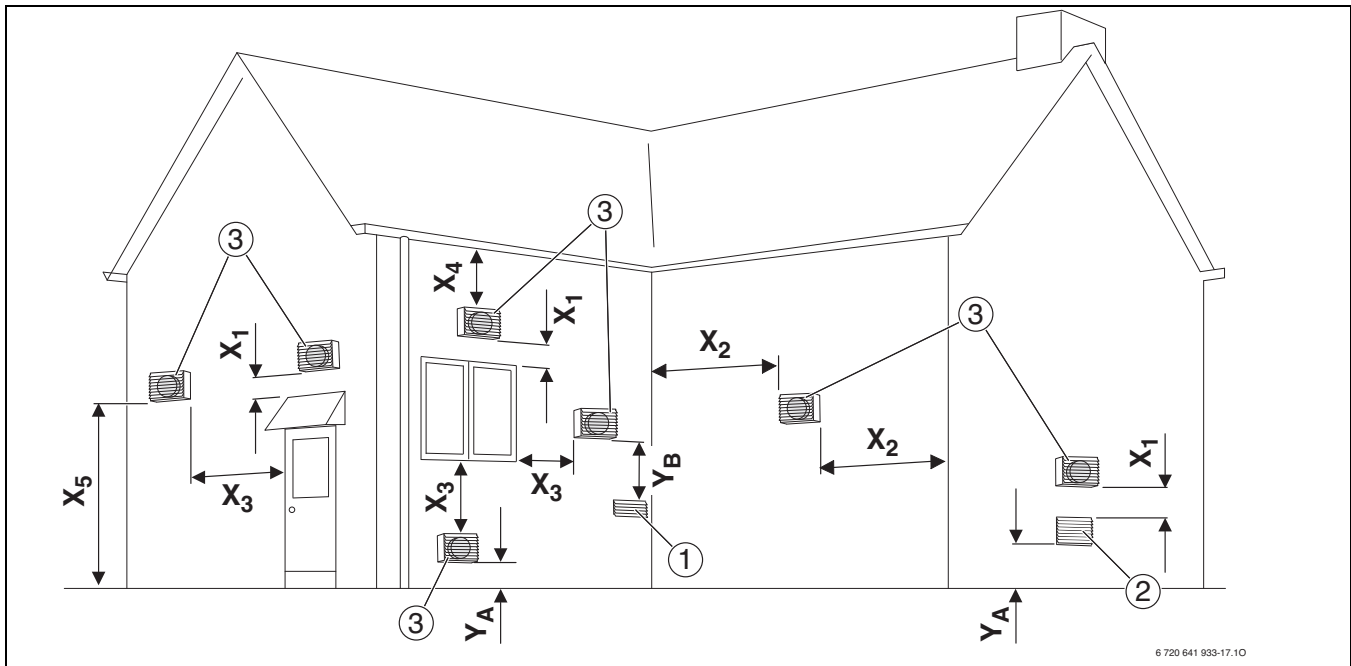

6 720 641 933-17.10

Fig. 31 Vent and combustion air pipe position

- [1] Forced Air Inlet
- [2] Gravity Air Inlet
- [3] Exhaust terminal
- X_1 1 foot (305 mm)
- X_2 Clearance in accordance with local installation codes and the requirements¹⁾
- X_3 1 foot (305 mm)
3 feet (915 mm) in Canada for models ZBR 35-3 A and ZBR 42-3 A
- X_4 Clearance in accordance with local installation codes and the requirements¹⁾
- X_5 7 feet (2 135 mm)²⁾
- Y_A At least 1 foot (305 mm) above grade or snow line
- Y_B Exhaust terminal must be at least:
3 feet (915 mm) above forced air inlet within
10 feet (3050 mm) horizontally - USA
6 feet (1830 mm) above forced air inlet - Canada

1) For Clearances not specified in ANSI Z223.1 / NFPA 54 or CSA B149.1
Clearance in accordance with local installation codes and the requirements of the gas supplier including the Authority Having Jurisdiction.

2) vent shall not terminate directly above a sidewalk or paved driveway that is located between 2 single family dwellings and serves both dwellings.

6.8.2 Examples of approved horizontal and vertical venting installation

NOTICE

- ▶ Place pipe supports every 5 ft (1 525 mm) of horizontal and vertical run, beginning with support near wall-mounted gas condensing boiler.
- ▶ Remove condensate in accordance with applicable regulations.
- ▶ Regularly clean the vent terminal and safety mesh.
- ▶ Avoid locating vent terminal near equipment or items that could be adversely affected by flue gases.
- ▶ When installing several appliances in a row, maintain a clearance of at least 1 ft (305 mm) between the vent terminal of one appliance and the combustion air inlet of the next appliance.

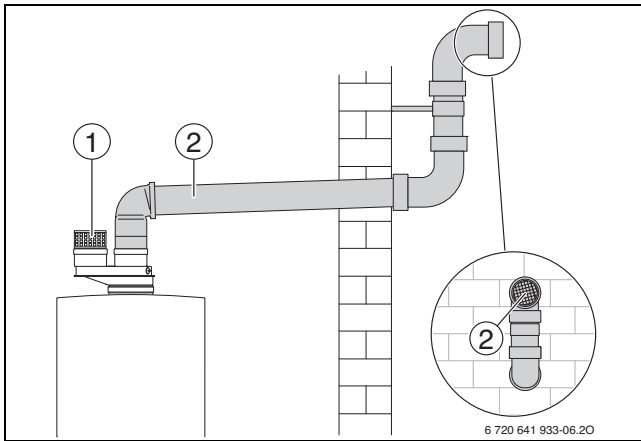

Fig. 32 Horizontal venting system (room air only)

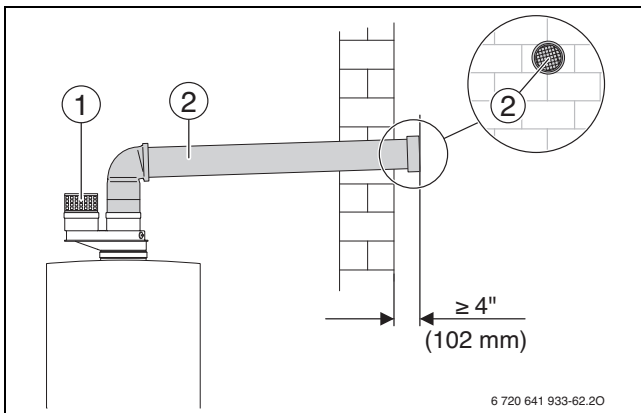

Fig. 33 Horizontal venting system (room air only)

Key to Fig. 32 and Fig. 33:

- [1] Intake
- [2] Exhaust

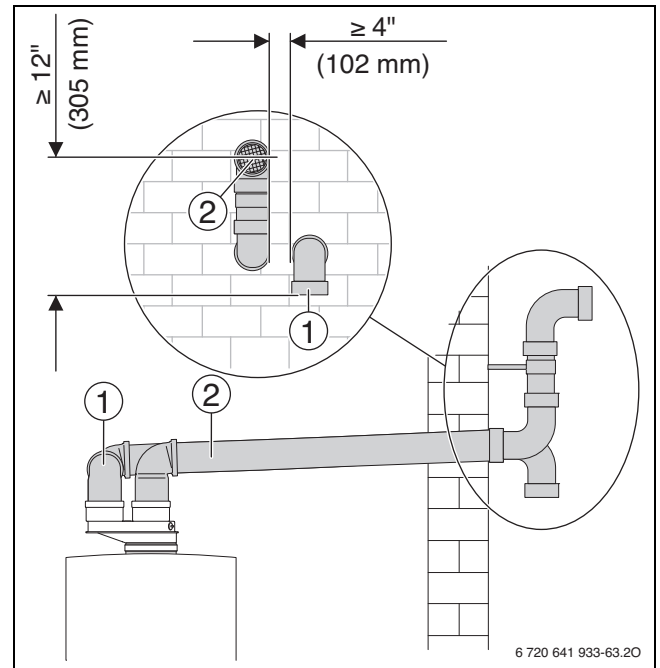

Fig. 34 Horizontal venting system (sealed combustion)

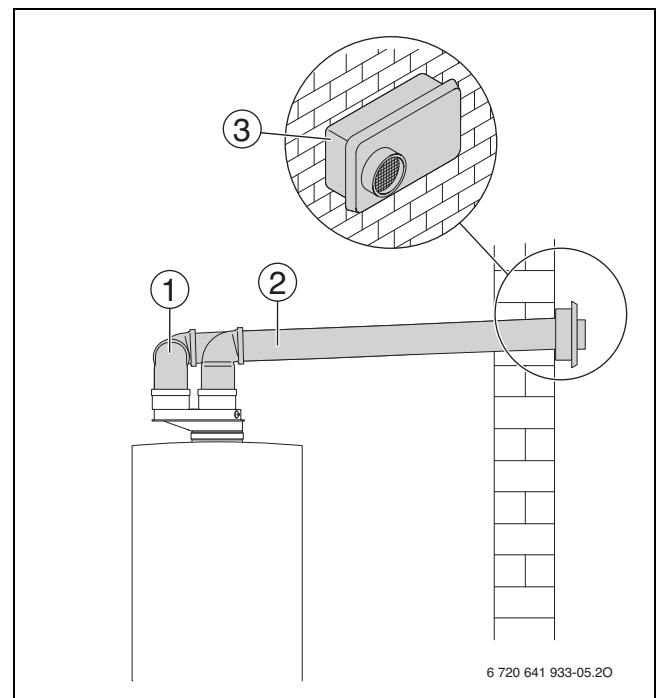

Fig. 35 Horizontal venting system (sealed combustion)

Key to Fig. 34 and Fig. 35:

- [1] Intake, behind exhaust
- [2] Exhaust
- [3] Wall termination

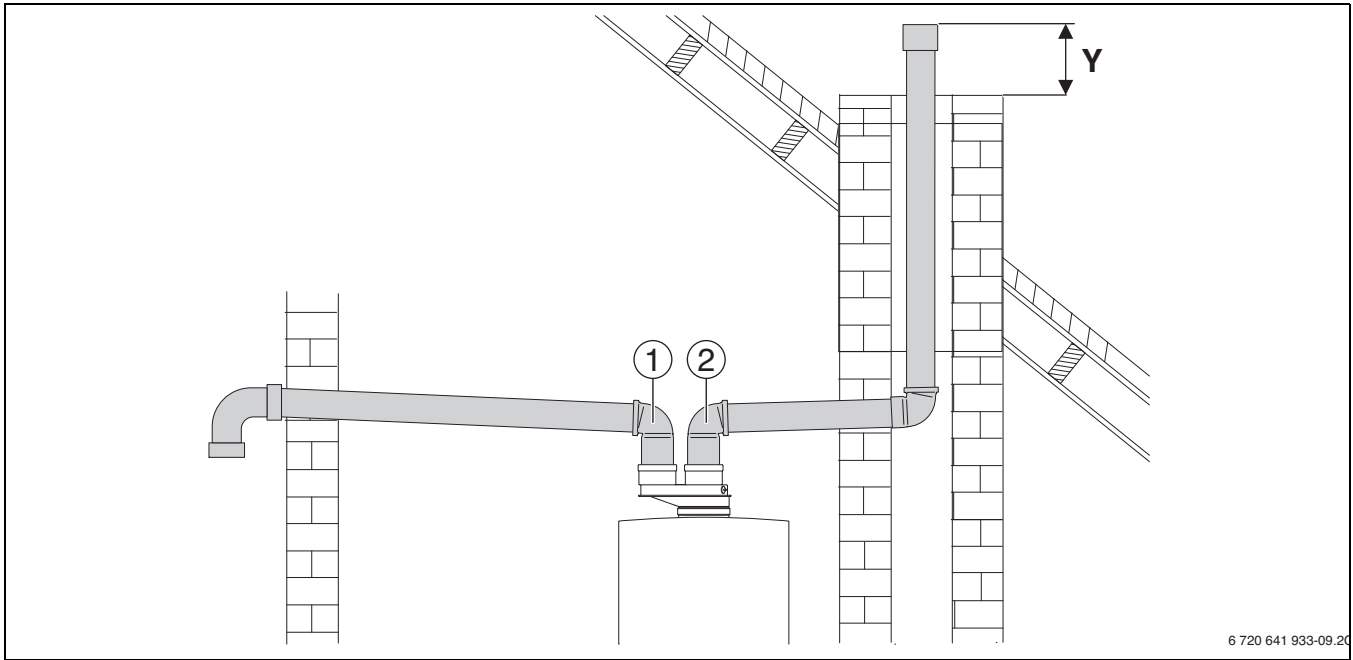

Fig. 36 Vertical venting system (sealed combustion)

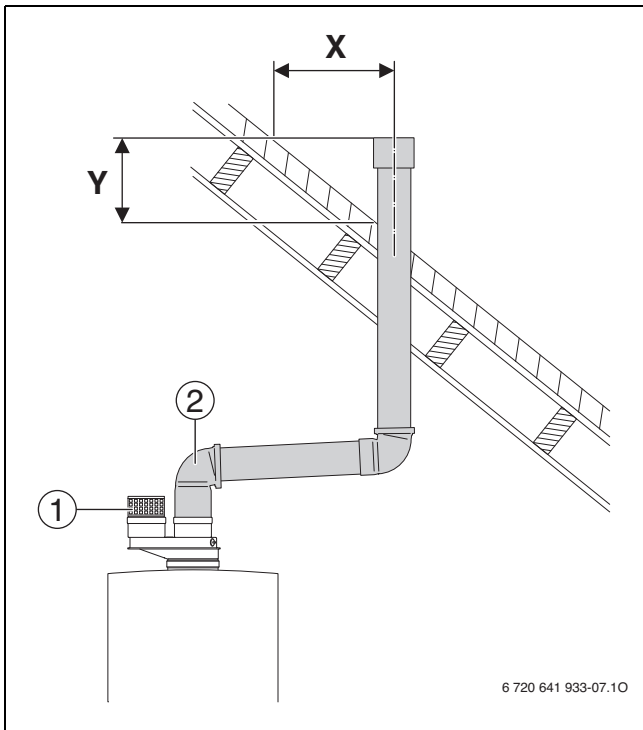

Fig. 37 Vertical venting system (room air only)

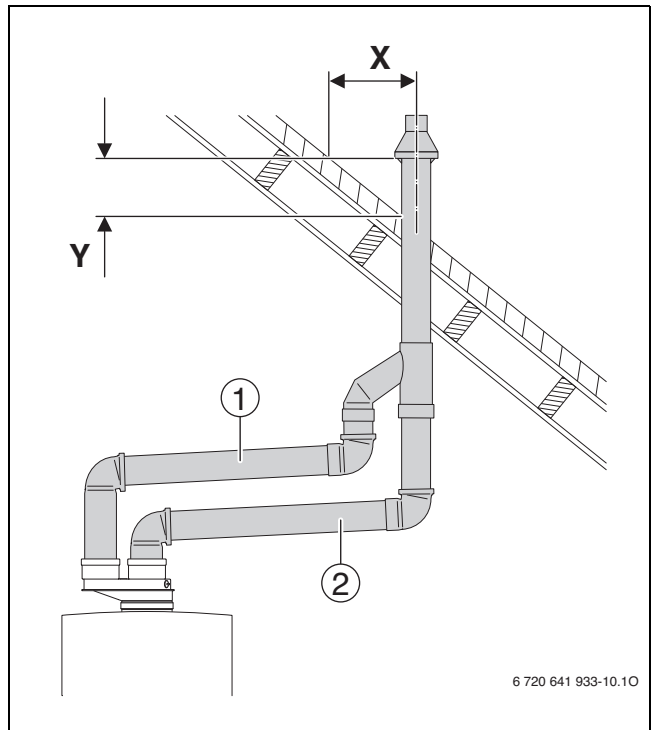

Fig. 38 Vertical venting system (sealed combustion)

Key to Fig. 36, Fig. 37 and Fig. 38:

- [1] Intake
- [2] Exhaust
- X Greater than 12 inches (305 mm)
- Y Greater than 12 inches (305 mm)

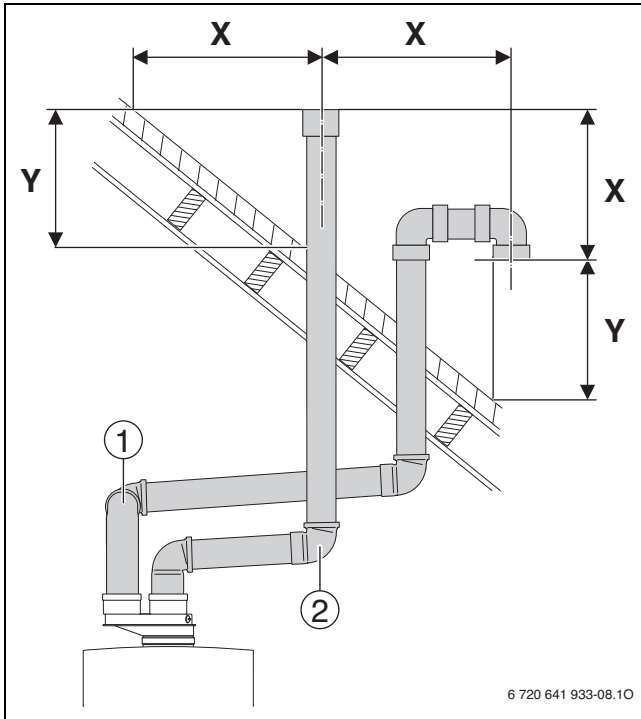

Fig. 39 Vertical venting system (sealed combustion)

- [1] Intake
- [2] Exhaust
- X Greater than 12 inches (305 mm)
- Y Greater than 12 inches (305 mm)

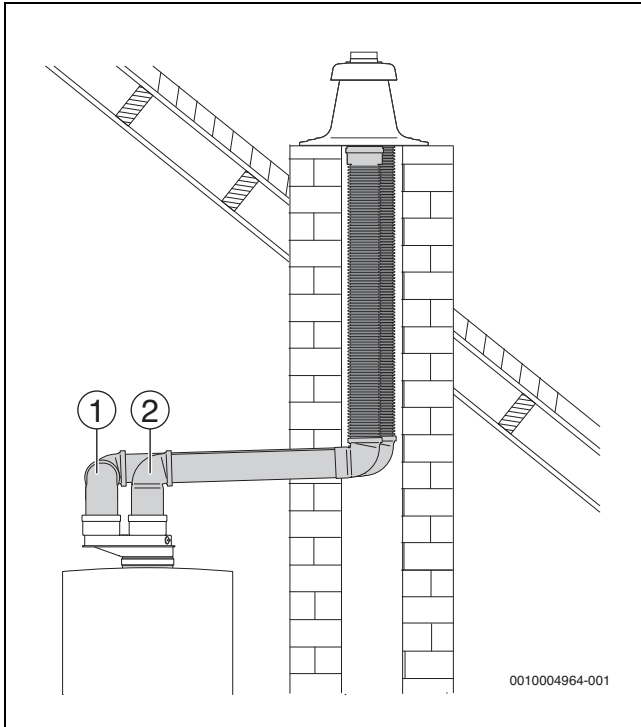

Fig. 40 PolyPro Flex chimney cap (PP) flue gas routing (sealed combustion)

- [1] Intake
- [2] Exhaust

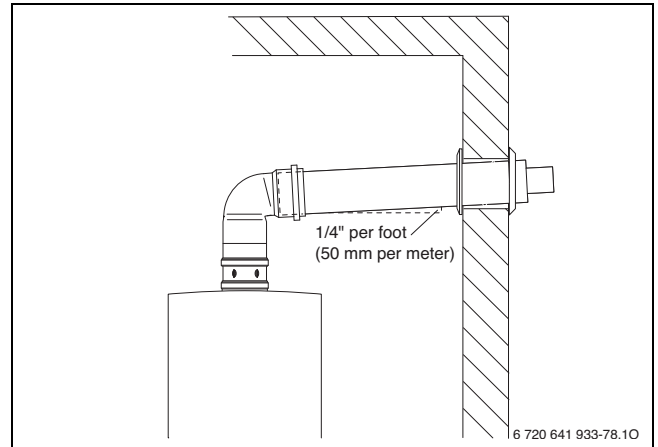

Fig. 41 Horizontal venting system (telescopic concentric vent kit)

6.8.3 Vent and combustion air pipe lengths



With Flex Pipe the maximum length is reduced by 50%. Flex Pipe according to the suppliers instructions for use in the vertical part of the installation only.

3" (76 mm) Vent and combustion air pipe

For all installation situations and for all appliances the maximum vent and combustion air pipe length is 100 feet each, with no more than 8 elbows each.

2" (50 mm) Vent and combustion air pipe

The maximum total combined equivalent length of vent and combustion air pipe (→ tab. 17, 18 and 19) depend on the installation situation, the appliance type and number of elbows used.

Installations → Fig. 32, 33, 34, 36, 37 and 39 Separate terminations

2"-PIPE Number of 90° elbows used	Maximum straight vent pipe length allowed for Ø 2" pipe	
	ZBR 21-3A ZBR 28-3A ZWB 28-3A	ZBR 35-3A ZWB 35-3A ZBR 42-3A ZWB 42-3A
1	81 ft (24.6 m)	65 ft (19.8 m)
2	76 ft (23.1 m)	57 ft (17.3 m)
3	71 ft (21.6 m)	48 ft (14.6 m)
4	66 ft (20.1 m)	40 ft (12.2 m)
5	61 ft (18.6 m)	32 ft (9.8 m)
6	56 ft (17.1 m)	23 ft (7.0 m)

Table 17 Vent and combustion air pipe lengths with 2" diameter and separate terminations

Installations → Fig. 35 Stainless steel wall termination		
2" PIPE	Maximum straight vent pipe length allowed for Ø 2" pipe	
Number of 90° elbows used	ZBR 21-3A	ZBR 35-3A
	ZBR 28-3A	ZWB 35-3A
	ZWB 28-3A	ZBR 42-3A
	ZWB 42-3A	
1	76 ft (23.1 m)	60 ft (18.3 m)
2	71 ft (21.6 m)	52 ft (15.9 m)
3	66 ft (20.1 m)	43 ft (13.1 m)
4	61 ft (18.6 m)	35 ft (10.7 m)
5	56 ft (17.1 m)	27 ft (8.2 m)
6	51 ft (15.6 m)	18 ft (5.5 m)

Table 18 Vent and combustion air pipe lengths with 2" diameter and the stainless steel wall termination

Installations → Fig. 38 Concentric termination		
2" PIPE	Maximum straight vent pipe length allowed for Ø 2" pipe	
Number of 90° elbows used	ZBR 21-3A	ZBR 35-3A
	ZBR 28-3A	ZWB 35-3A
	ZWB 28-3A	ZBR 42-3A
	ZWB 42-3A	
1	66 ft (20.1 m)	47 ft (14.3 m)
2	61 ft (18.6 m)	38 ft (11.6 m)
3	56 ft (17.1 m)	30 ft (9.1 m)
4	51 ft (15.6 m)	22 ft (6.7 m)
5	46 ft (14.1 m)	13 ft (4.0 m)
6	41 ft (12.5 m)	5 ft (1.5 m)

Table 19 Vent and combustion air pipe lengths with 2" diameter and the concentric termination

Ø 3" / Ø 5" (Ø 80/125 mm) Concentric venting system

The maximum total concentric pipe length (→ tab. 20) depends on the installation situation, the appliance type and the number of elbows used.

Installations → Fig. 41		
Ø 3" / Ø 5" (Ø 80/125 mm) CONCENTRIC PIPE	Maximum straight vent pipe length allowed for Ø 3" / Ø 5" (Ø 80/125 mm) concentric pipe	
Number of 90° elbows used	ZBR 21-3A	ZBR 35-3A
	ZBR 28-3A	ZWB 35-3A
	ZWB 28-3A	ZBR 42-3A
	ZWB 42-3A	
1	50 ft (15.2 m)	44 ft (13.4 m)
2	44 ft (13.4 m)	38 ft (11.6 m)
3	38 ft (11.6 m)	32 ft (9.8 m)
4	32 ft (9.8 m)	26 ft (7.9 m)
5	26 ft (7.9 m)	20 ft (6.1 m)
6	20 ft (6.1 m)	14 ft (4.3 m)

Table 20 Pipe lengths with Ø 3" / Ø 5" (Ø 80/125 mm) diameter and termination

Fitting	Equivalent	
	ft	m
45° elbow	3	0.91
90° elbow	6	1.82

Table 21 Concentric pipe friction loss equivalent for fittings

Example:

- Model: **ZBR 28-3A**
- 90° elbows used: **2**
- 45° elbows used: **2**

Maximum straight vent pipe allowed: **38ft (11.6 m)**

6.9 Testing gas and water connections for leaks

NOTICE

Pressure, control and safety equipment may be damaged by excessive pressure.

- ▶ When you carry out a leakage test, make sure that no pressure, control or safety equipment is installed that cannot be isolated from the test pressure.
- ▶ The boiler and its dedicated shutoff valve must be disconnected from the gas supply piping system during any pressure testing of that system at test pressures in excess of 14" W.C. (35 mbar).

Water connections

- ▶ Open the heating supply and return valves and fill the heating system.
- ▶ Check all connections for leakage (test pressure: Max. 30 psi (2.07 bar) on the pressure gauge).

Gas line

- ▶ Close the gas shutoff valve to protect the gas valve from damage.
- ▶ Check all connections for leakage (test pressure: Max. 60" W.C. (150 mbar)).
- ▶ Release pressure.

7 Electrical connection

7.1 General notes



DANGER

Risk of electric shock!

- ▶ Before working on the power supply (120 VAC), disconnect the boiler from the grid by shutting off the emergency shutoff switch or disengaging the heating system circuit breaker. Take measures to prevent accidental reconnection.
- ▶ It is not sufficient to simply shut off the controls.
- ▶ Observe all applicable electrical codes and regulations.

Electrical components must be installed by a trained and certified electrician and the installation must meet the National Electric Code as well as all applicable local codes and regulations.

The boiler must be properly electrically grounded in accordance with the requirements of the authority having jurisdiction or, in the absence of such requirements with the National Electrical Code, ANSI/NFPA 70 and/or the Canadian Electrical Code Part I, CSA C221.1, Electrical Code.



Provide a dedicated circuit breaker for the boiler and heating system rated at least 15A. All line voltage wiring must use at least AWG14 size cables.

All appliance modulation, control and safety components are tested and pre-wired for use.

Observe safety precautions and all rules and regulations required by local code and the National Electric Code.

Fuses

The appliance is protected with a fuse. It is located on the circuit board (→ Fig. 8, page 14).



Replacement fuses can be found on the back of the cover (→ Fig. 43, page 43).

Controls and modules

For installation and electrical connection of controls and modules, see the installation instructions of the accessory.

7.2 Low voltage electrical connections in the Heatronic boiler control

7.2.1 Open the Heatronic boiler control

NOTICE

Small pieces of wire can cause shorts and damage the electronics.

- ▶ Always strip cables away from electronics.
- ▶ Unhook the clip (step 1) and fold the Heatronic down (step 2).

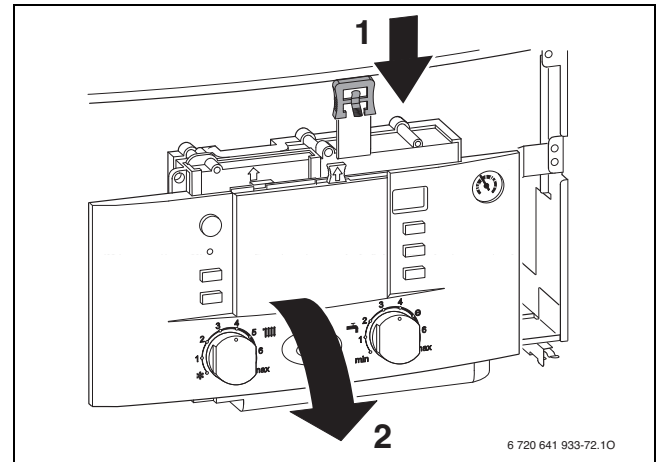

Fig. 42 Fold the Heatronic down

- ▶ Remove screws (step 1), unhook cable and remove cover (step 2).

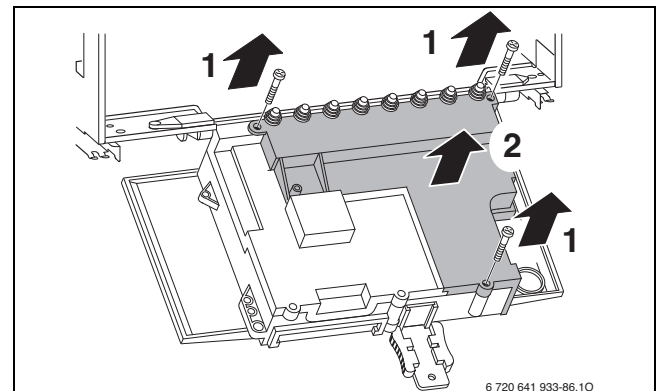

Fig. 43 Remove the cover

7.2.2 Connecting the BUS-system

Connect only Bosch room controls to the internal BUS of this boiler. For further details see the technical documentation of the BUS system components (e. g. CRC200 and CZM100).

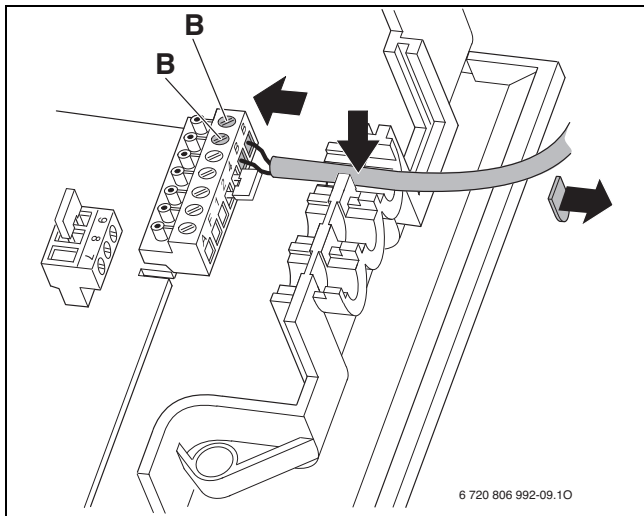

Fig. 44 Electrical wiring BUS-cable at the boiler

▶ Secure the cable on the strain relief.

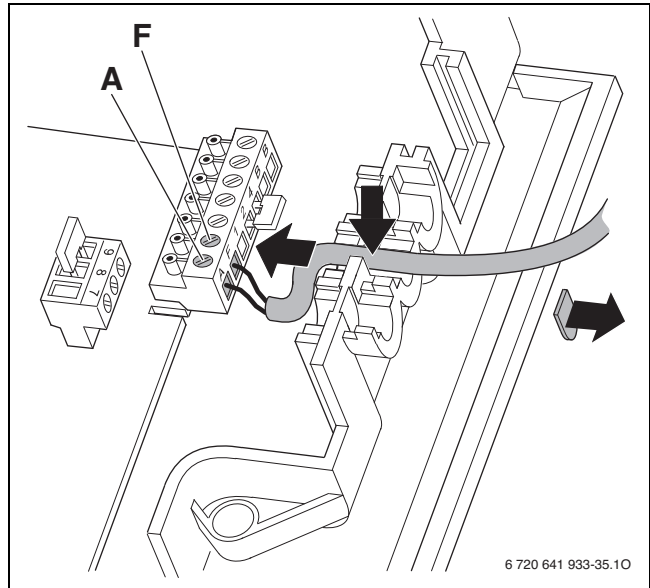

Fig. 46 Electrical wiring outdoor temperature sensor

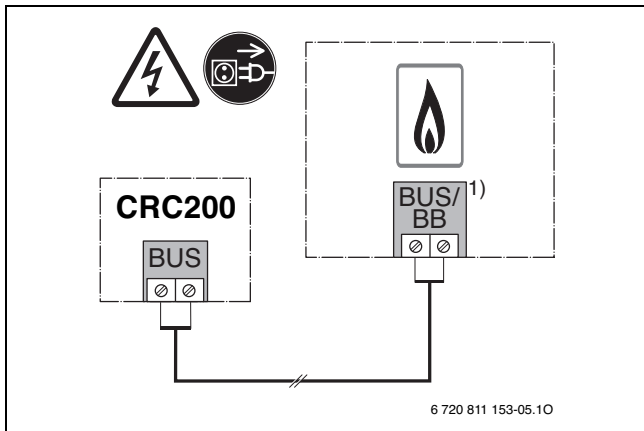

Fig. 45 Schematic of electrical wiring of Bosch room control and boiler

7.2.4 Connecting the DHW tank temperature sensor (only ZBR...-3A)

Wire the DHW tank temperature sensor directly to the appliance terminals. The sensor is provided with the appliance.

Do not exceed a sensor cable length of 33 feet (10 m).

- ▶ Punch out plastic insert.
- ▶ Plug connector into the circuit board.
- ▶ Insert the cable of the DHW tank temperature sensor.
- ▶ Secure the cable with the strain relief.

1) Terminal at the boiler reads BUS or BB, both indicating connection of the 2-wired Bosch BUS system.

7.2.3 Connecting the outdoor temperature sensor

- ▶ Set up WWSD according to the instruction manual of CRC200.
- ▶ Punch out plastic insert.
- ▶ Connect cable of the outdoor temperature sensor according to Fig. 46.
- ▶ Insert cable for the outdoor temperature sensor.

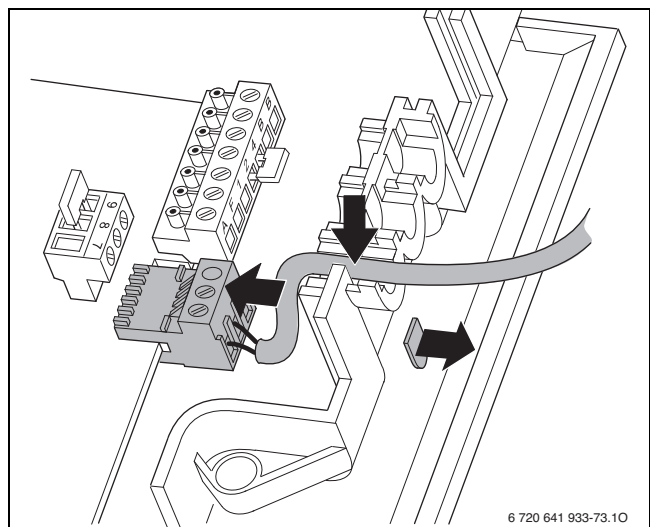

Fig. 47 Electrical connections DHW tank temperature sensor

7.2.5 Connecting additional accessories

- ▶ For splash protection (IP), always cut the strain relief to match the diameter of the cable.

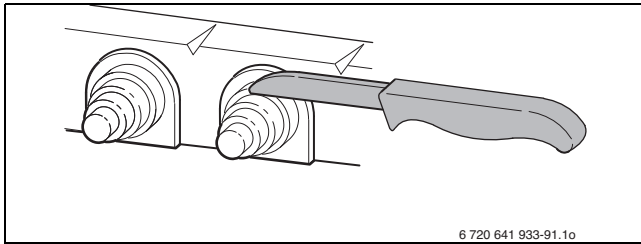

Fig. 48 Cut off grommets

- ▶ Feed cable through strain relief and connect accordingly.
- ▶ Secure the cable on the strain relief.

Connecting temperature guard TB 1 (external manual reset high limit or low water cut off (LWCO))

This connection allows the installation of external safety switches.

- External manual reset high limit
- Low water cut-off (LWCO)
- Radiant overheate protection

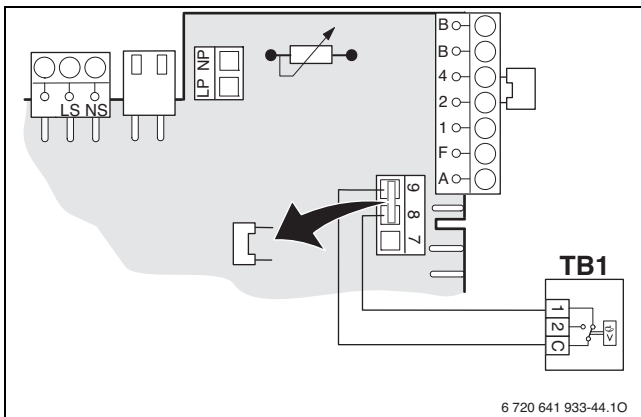

Fig. 49 Electrical wiring TB 1

When the temperature guard trips, central heating and DHW modes are interrupted.

Connecting the supply temperature sensor (e.g. for low-loss header or system supply pipe)

Do not exceed a sensor cable length of 33 feet (10 m).



Supply temperature sensor for system supply pipe (Fig 50, [2]) must be installed in closest vicinity with boiler supply Tee.

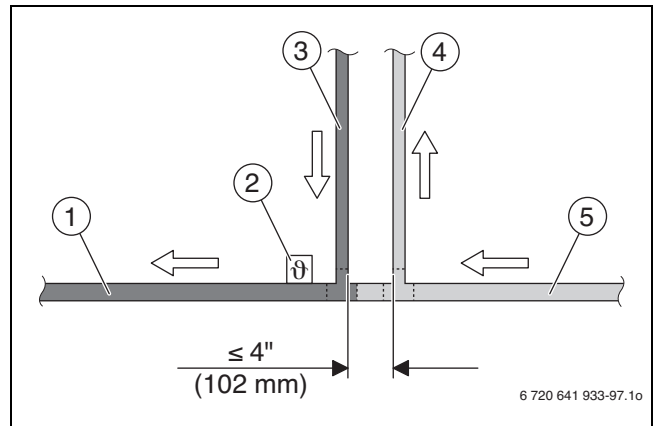

Fig. 50 Mounting supply temperature sensor right next to boiler supply

- [1] System secondary line – supply pipe
- [2] Supply temperature sensor for system supply pipe
- [3] Boiler primary line – supply pipe 1"
- [4] Boiler primary line – return pipe 1"
- [5] System secondary line – return pipe

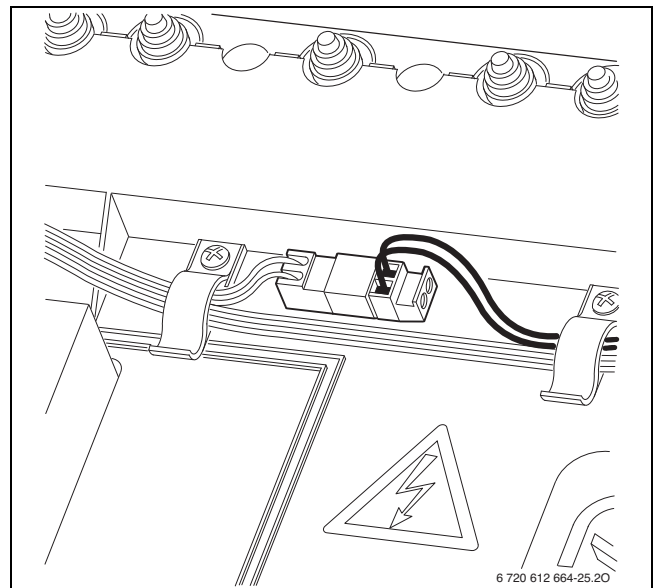

Fig. 51 Electrical wiring of external supply temperature sensor

The service function 7.d connection of an external supply temperature sensor is automatically set to 01 (→ page 60).

Connecting Third party room thermostats or zone controls

A voltage free (dry contact) third party room thermostat or heat demand from a relay panel can be used to send an ON/OFF signal to the appliance.

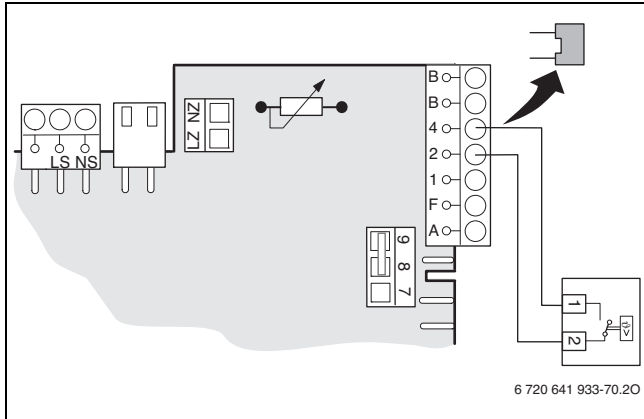

Fig. 52 Electrical wiring third party room thermostat or zone control

To communicate a heat demand the third party room thermostat or zone control must connect pins 2 and 4.

7.3 Electrical connections in the junction box (120 VAC)

7.3.1 Mounting rails for junction box

- ▶ Hold the rail against the appliance from below (step 1) and fasten with the screws from the outside or inside (step 2).
- ▶ Loosen junction box from the rail (step 3).

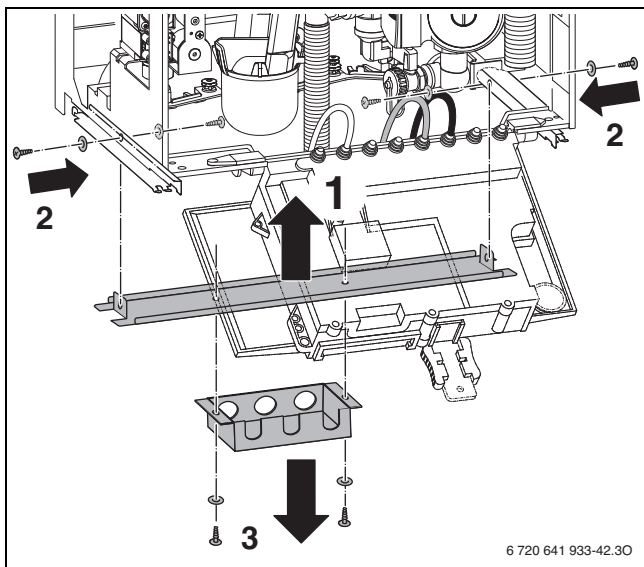

Fig. 53 Mounting rails for junction box

7.3.2 Connecting an external heating zone pump or DHW recirculation pump

Without accessories the appliance offers the connection of one heating zone pump, one circulator of an unmixed heating circuit, or one DHW recirculation pump.

The pump used must have the following connection values: 120 VAC, max. 2 A.

- ▶ Route cable from pump to appliance.
- ▶ Insert cable into the junction box as shown in Fig. 55.
- ▶ Connect cable to **the black plug** according to Fig. 54.

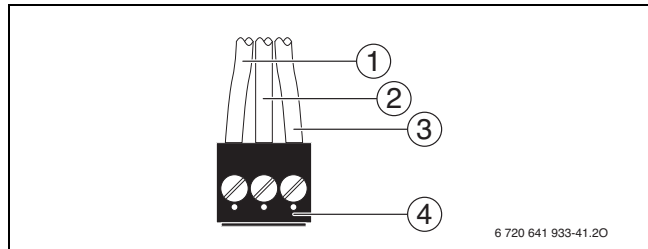

Fig. 54 Attach plug (external pump)

- [1] L (120 VAC, 60 Hz)
- [2] PE (GND, Ground)
- [3] N (Neutral)
- [4] Black plug (in the junction box upon delivery)

- ▶ Connect black plugs and insert grommet until stop.

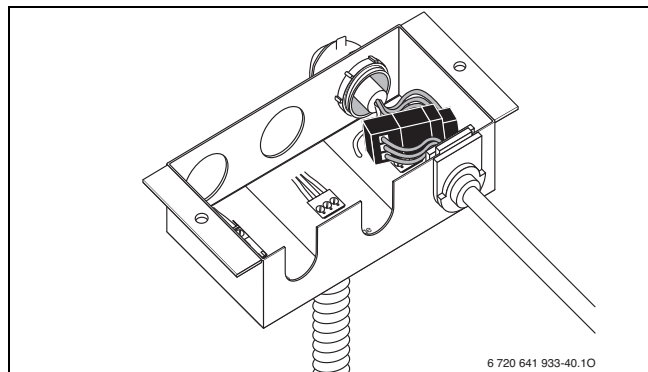

Fig. 55 Cable connected (external pump)

- ▶ Use service function 5.E, to set connection to **01** (DHW recirculation pump) (→ page 59).

-or-

- ▶ Use service function 5.E to set connection to **02** (external heating zone pump in an unmixed heating circuit).

-or-

- ▶ Use service function 5.E to set connection to **03** (external heating pump).



The DHW recirculation pump is controlled by the Bosch Room Controller.

7.3.3 DHW tank loading pump or 3-way valve with spring return (only ZBR...-3A)

The pump used must have the following connection values: 120 VAC, max. 2 A.

- ▶ Route cable from pump or 3-way valve to appliance.
- ▶ Insert cable into the junction box as shown in Fig. 57.
- ▶ Connect cable to **the red plug** according to Fig. 56.

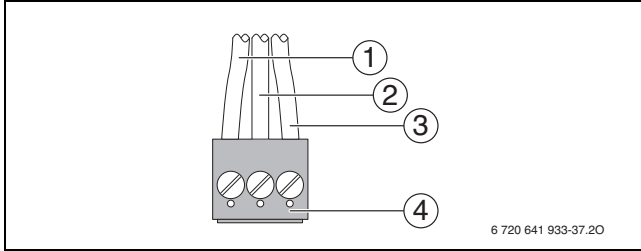

Fig. 56 Attach plug (external DHW tank loading pump or 3-way valve)

- [1] L (120 VAC, 60 Hz)
 - [2] PE (GND, Ground)
 - [3] N (Neutral)
 - [4] Red plug (in the junction box upon delivery)
- ▶ Connect red plugs and insert grommet until stop.

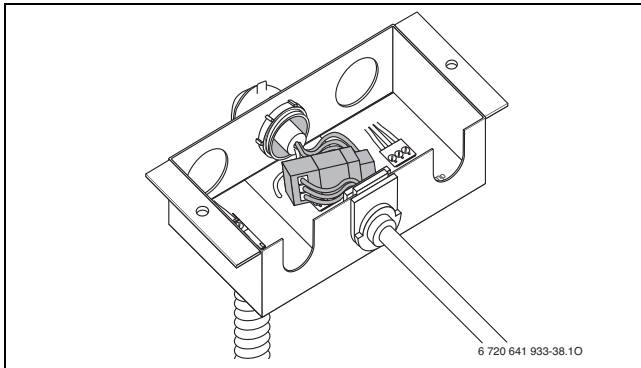

Fig. 57 Cable connected (external DHW tank loading pump or 3-way valve)

- ▶ Mount the 3-way valve for space heating operation when de-energized, and DHW tank loading when energized.
- ▶ Use service function 1.F to set pump mode (→ page 57).

7.3.4 Connecting mains power supply

- ▶ Route the power cable (AC 120 V, 60 Hz) from the emergency shutoff switch to the boiler.
- ▶ Insert cable into the junction box as shown in Fig. 59.

- ▶ Connect cable to **the white plug** according to Fig. 58.

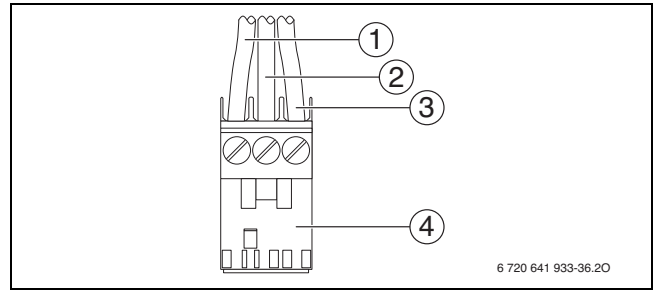

Fig. 58 Attach plug (mains power supply)

- [1] L (120 VAC, 60 Hz)
- [2] PE (GND, Ground)
- [3] N (Neutral)
- [4] White plug (in the junction box upon delivery)

- ▶ Connect white plugs and insert grommet until stop.

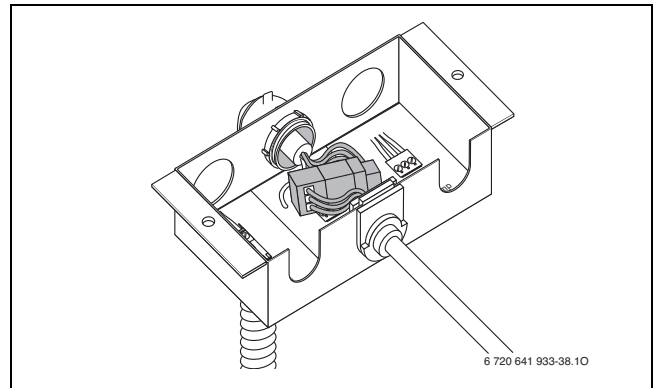

Fig. 59 Cable connected (mains power supply)

- ▶ Mount junction box on the rail.

7.4 Connecting the LWCO device

NOTICE

System damage or malfunction!

- ▶ Ensure the air box remains air-tight when routing the LWCO cable to the outside.
 - ▶ Do not route the LWCO cable through the ignition cable grommet as appliance malfunction may occur.
-
- ▶ Push the existing cable grommet of the fan cable down through air box sheet.
 - ▶ Slip new cable grommet over the cable.
 - ▶ Insert new cable grommet into the air box sheet.
 - ▶ Push old cable grommet back up and into new cable grommet.
 - ▶ Insert cable of the LWCO device into the second hole of the cable grommet.

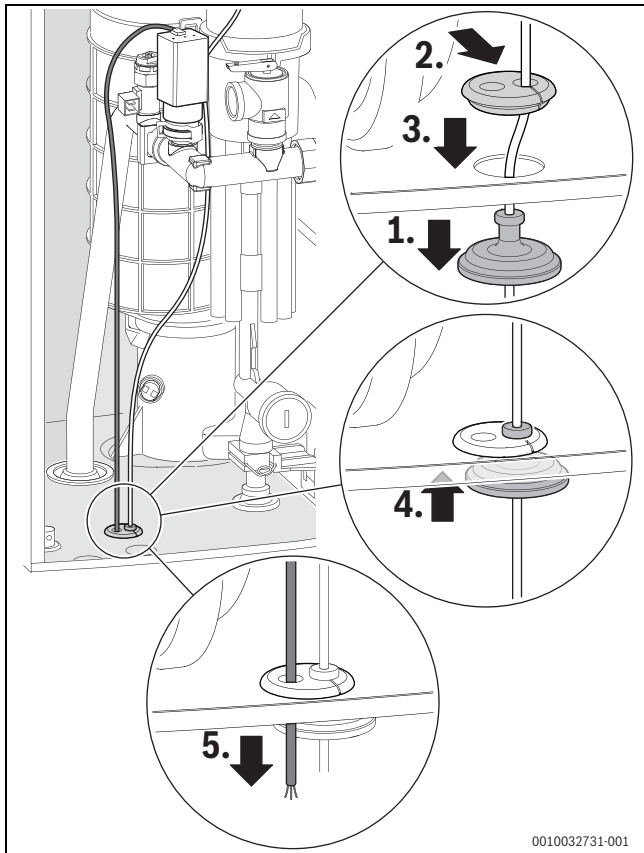

Fig. 60 Mounting the cable grommet (included in scope of delivery)

- ▶ Install a 24 VAC 20 VA transformer near the boiler.
- ▶ Follow LWCO manufacturer's instructions.
- ▶ Connect the lead labeled BOILER GROUND (green) to pin 2 (center) of the white plug in the junction box of the wall-mounted gas condensing boiler.
- ▶ Connect the two leads labeled 24 V HOT (red) and 24 V COMMON (white) to the external 24 VAC transformer.

- ▶ Connect the leads labeled SWITCH CONTACT (yellow) to the TB1 temperature switch (→ Fig. 49, page 45) on the Heatronic.

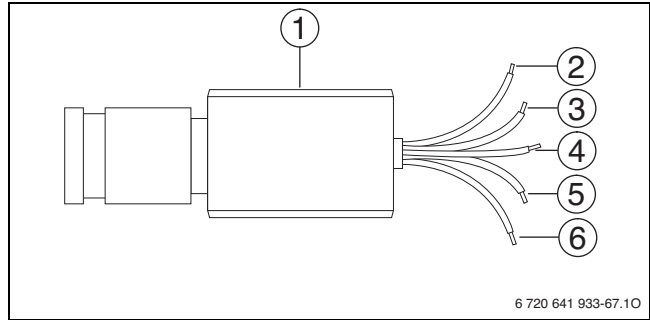

Fig. 61 Wires of a LWCO device with LWCO adapter

- [1] LWCO device (Hydrolevel Safgard 1100)
- [2] BOILER GROUND (green)
- [3] SWITCH CONTACT (yellow)
- [4] SWITCH CONTACT (yellow)
- [5] 24 V HOT (red)
- [6] 24 V COMMON (white)

8 Commissioning

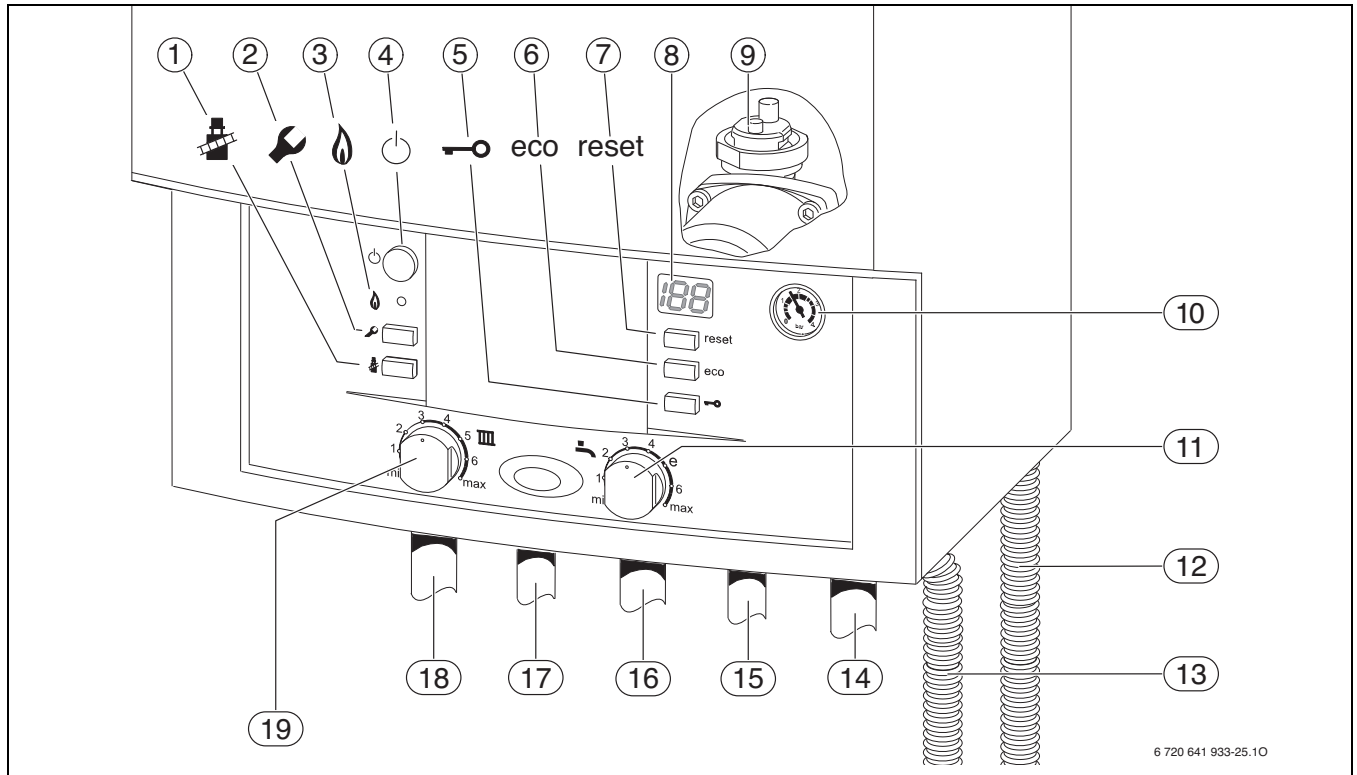

Fig. 62 Overview of the controls

- [1] Emissions test button
- [2] Service button
- [3] Burner operation indicator lamp
- [4] ON/OFF power switch
- [5] Key pad lock
- [6] ECO button
- [7] Reset button
- [8] Display
- [9] Automatic air vent (ZWB...-3A combi boilers only)
- [10] Boiler water pressure gauge
- [11] DHW thermostat
- [12] Safety relief valve discharge hose
- [13] Condensate drain hose
- [14] Heating return pipe
- [15] Cold water pipe (ZWB...-3A combi boilers only)
- [16] Gas pipe
- [17] DHW pipe (ZWB...-3A combi boilers only)
- [18] Supply pipe
- [19] Boiler high limit dial

8.1 Before operating the appliance

NOTICE

Commissioning without being properly filled and purged will damage the appliance.

- ▶ Only operate this appliance after ensuring there is sufficient water in the boiler and the system.
-
- ▶ Adjust the expansion vessel pre-charge pressure to the static head of the heating system (→ page 30).
 - ▶ Open radiator and zone valves (as applicable).
 - ▶ Open heating supply and return valves, fill heating system to 14.5 to 21.75 psi (1 - 1.5 bar) and close fill valve.
 - ▶ Bleed all air from the system.
 - ▶ If the boiler water pressure has dropped, fill the heating system again to 14.5 to 21.75 psi (1 to 1.5 bar).
 - ▶ On ZBR...-3A appliances (heating boilers) with a DHW tank, open the cold water supply and open a DHW tap until water runs out.
 - ▶ Verify that the gas type specified on the rating plate is the same as the gas type used.
 - ▶ Open the gas cock.

8.2 Switching the appliance ON/OFF

Startup

- ▶ Switch the appliance ON using the ON/OFF switch. The display indicates the supply temperature of the hot water in °F. If necessary, convert to °C (→ page 60).

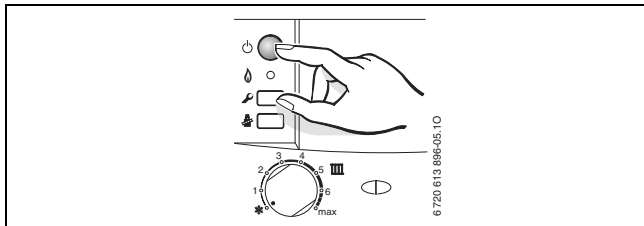



Fig. 63 Switching the appliance ON/OFF



When the appliance is switched ON for the first time, it performs a once-only purging sequence. This involves the heating zone pump switching on and off at intervals (for approx. 4 minutes). The display shows  in alternation with the supply temperature.

- ▶ Open the automatic vent [9] (only ZWB...-3A) and close it again when the purging sequence has finished (→ page 49).



If the display shows  in alternation with the supply temperature, the trap filling function is active (→ page 59).

Shutdown

- ▶ Switch appliance OFF using the ON/OFF switch. The display goes out.
- ▶ If the appliance is taken out of service for a longer period: Observe frost protection (→ Section 8.9).

8.3 Heat setting

8.3.1 Switching on the heating

Set the maximum supply temperature based on the structure's heat loss on design day.



Boiler high limit dial 	Typical supply temperatures	Sample application
1	approx. 95 °F (35 °C)	Frost protection
2	approx. 109 °F (43 °C)	
3	approx. 122 °F (50 °C)	Radiant floor heating system
4	approx. 140 °F (60 °C)	Panel radiator system
5	approx. 153 °F (67 °C)	Cast iron radiator system
6	approx. 167 °F (75 °C)	
max	approx. 187 °F (86 °C)	Baseboard and convactor system

Table 22 Typical supply temperatures



With radiant floor heating, limit the maximum permissible supply temperature as recommended by the manufacturer.

- ▶ In order to set the maximum supply temperature, turn the supply temperature dial  knob.

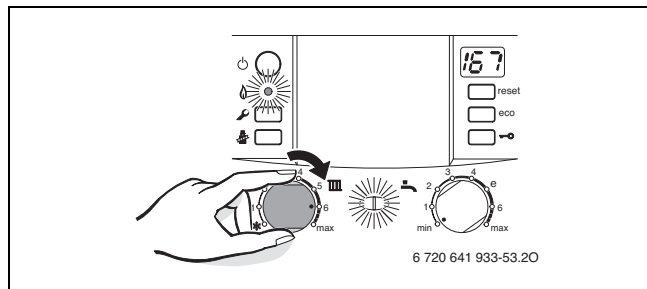

Fig. 64 Switch on heat

If the burner is operating, the burner operation indicator lamp is illuminated.

8.3.2 Optional - Activate Outdoor Reset

The appliance will modulate the CH flow temperature based on the outside temperature when an outdoor sensor is connected to the outdoor sensor connection on the control board and the outdoor reset is active.

This is designed for use with a system that has thermostatic radiator valves and a room thermostat.

The appliance will operate at lower temperatures when there is a lower heat load because the building is losing less heat due to higher external temperatures. This means that the appliance is running more efficiently as it is operating for longer at condensing temperatures.

The outdoor reset curve can be adjusted to tune the flow temperature to suit the particular installation.

The appliance is supplied with the outdoor reset deactivated.

Outdoor reset activation:

The outdoor reset is activated via the Service menu.

- ▶ Select P0 and set the summer shut down temperature to activate outdoor reset. Standard setting is 32 °F (0 °C) which is outdoor reset turned off. P0 can be set between 33 - 86 °F (1 - 30 °C) outdoor temperature.
- ▶ Ensure Outdoor sensor is installed according to → Fig. 65 and connected as indicated in → Fig. 66 if no outdoor sensor is detected/ fitted the error code CC will be shown.

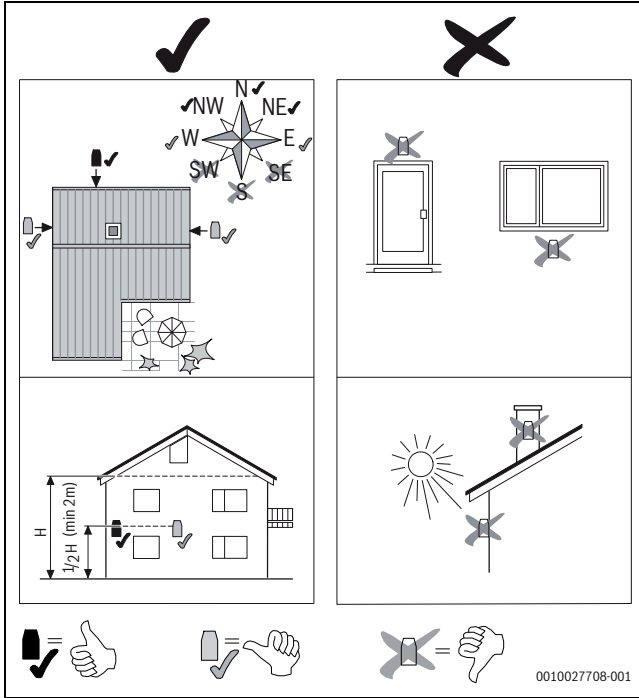

Fig. 65 Outdoor reset sensor optimum positioning indicated by black tick

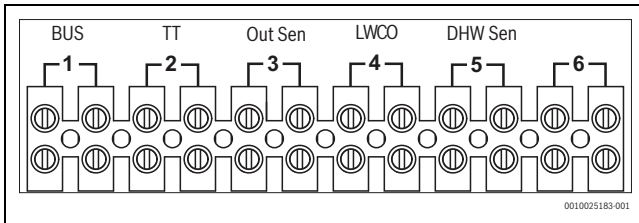

Fig. 66 Connect Outdoor sensor to "Out Sen" number 3

The heating curve

The CH flow temperature has an upper limit of 190 °F (88 °C) this can be capped via the CH control knob setting) and a lower limit of 95 °F (35 °C), (it is recommended that the CH knob is set to the highest design temperature fitting to the installed heating system for the outdoor reset to operate most effectively → table 22).

The default settings for the curve are point A = 194 °F (90 °C) and point B = 104 °F (40 °C), this gives a 176 °F (80 °C) flow at 25 °F (-4 °C) outdoor temperature and a 122 °F (50 °C) flow at 57 °F (14 °C) outdoor temperature which should be suitable for typical systems.

P1 is the base temperature of the heating curve at 68°F (20°C) outdoor temperature and P2 is the projected target flow temperature at 14°F (-10°C). (These values are only used to determine the slope of the heating curve not for CH flow temperature limits)

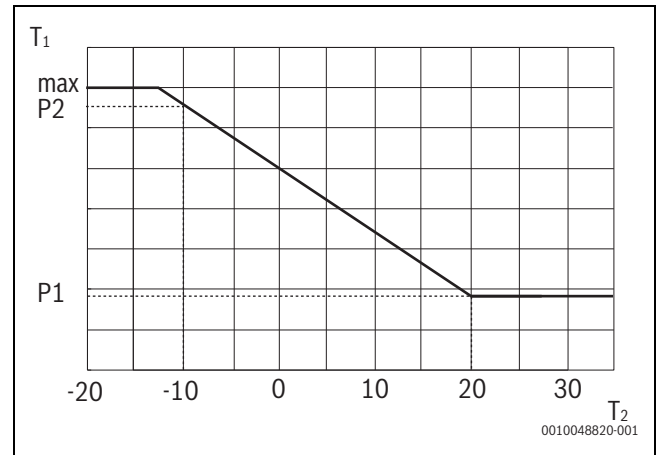

Fig. 67 Heating curve

- [P1] Base temperature of the heating curve
- [P2] Slope of the heating curve
- [T₁] Weather dependant set point in °C
- [T₂] Average outdoor temperature in °C

Adjusting the heating curve

- ▶ The heating curve can be adjusted in the service menu by changing P1 and P2 to set up a basic heating curve as indicated in → Fig. 67
- ▶ The base temperature P1 (CH design temperature at 68 °F (20 °C)) can be set between 68 - 122 °F (20-50 °C)
- ▶ The heating curve slope will be set through the end point temperature P2 at 14 °F (-10 °C) and can be adjusted between 122-194 °F (50-90.5 °C).

Outdoor sensor error

- ▶ if the outdoor sensor disconnects during operation the CH system will fall back to a fixed flow temperature of 122 °F (50 °C) and the appliance will show the error code CC
- ▶ The appliance will monitor the outdoor sensor input and if the sensor returns to normal then the flow temperature modulation will be reactivated and the LCD warning triangle and H03 are turned Off, (there may be a 10 second delay).

Average outdoor temperature

- ▶ To stop rapid fluctuations the outdoor temperature used for CH flow temperature modulation is an average value taken over a ten minute period.
- ▶ When an outdoor sensor is first detected the sensor value is taken to be the outdoor temperature, subsequently to this the outdoor temperature will be adjusted every 10 minutes using an average outdoor temperature value from the previous 10 minute period.

Frost protection

- ▶ To ensure system frost protection is working the control knob of the appliance must be set to a minimum flow temperature of 95 °F (35 °C)

8.4 Programming the Bosch Room Controller



Observe the operating instructions for the Bosch room controller included in the scope of delivery. There you can read:

- ▶ How to set the operating mode
- ▶ How to adjust the room temperature
- ▶ How to heat economically and comfortably
- ▶ How the control can be mounted in the living space

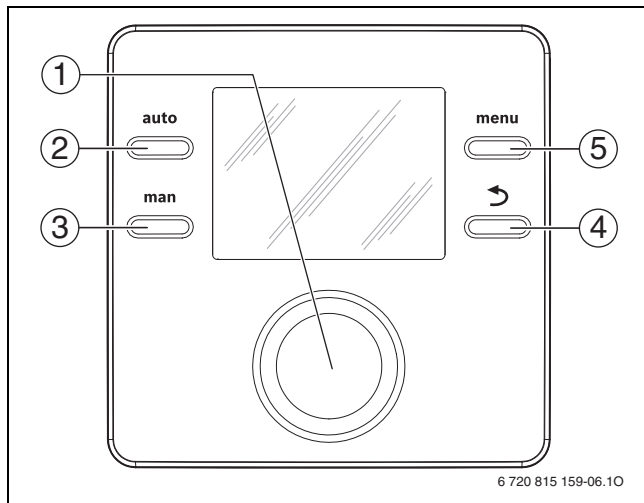

Fig. 68 Controls of the CRC200 controller

Legend			
Item	Element	Designation	Explanation
1		dial	<ul style="list-style-type: none"> ▶ Turn to change a setting or select a menu/menu item. ▶ Press to open a menu/menu item or confirm a setting/message.
2		auto button	▶ Press to activate the automatic mode.
3		man button	▶ Press to activate the hold mode (manual operation)
4		Back button	<ul style="list-style-type: none"> ▶ Press to return to the higher menu level or discard a setting. ▶ Press for an extended period of time to close the main menu.
5		menu button	▶ Press to open the main menu.

Table 23 Controls of the CRC200 controller

8.5 After commissioning

- ▶ Check flue path for tightness.
- ▶ Check gas supply dynamic pressure (→ page 64).
- ▶ Check that condensate is being discharged from the condensate hose. If that is not the case, switch the appliance first OFF and then ON again using the ON/OFF switch. That activates the trap filling sequence (→ page 59). Repeat the procedure several times until condensate starts running out.
- ▶ Complete commissioning report (→ page 78).

8.6 ZBR...-3A appliances (heating boilers) with DHW tank: Setting the DHW temperature

- ▶ Set the DHW temperature on the DHW thermostat . The set DHW temperature flashes on the display for 30 seconds.

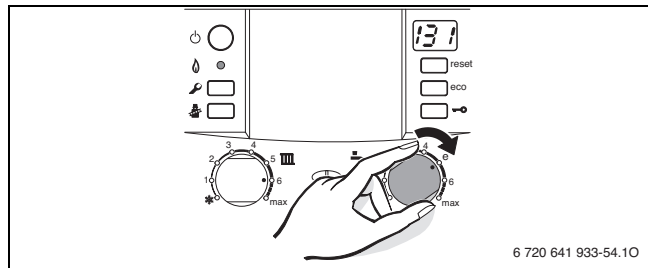

Fig. 69 Set the DHW temperature (ZBR...-3A)

DHW thermostat	Typical DHW temperatures
min	approx. 59 °F (15 °C)
e	approx. 131 °F (55 °C)
max	approx. 158 °F (70 °C)

Table 24 Typical DHW temperatures for ZBR...-3A appliances

WARNING

Danger of scalding!

- ▶ In normal operation, it is recommended to limit the DHW temperature to 122 °F (50 °C) to limit the risk of scalding.
- ▶ Install a tempering valve if running DHW temperatures above 104 °F (40 °C).
- ▶ Only use temperatures up to 158 °F (70 °C) for thermal disinfection (→ page 54).



If there is reason for concern for contamination from bacteria such as legionella, consider setting the DHW thermostat to at least “e” (131 °F (55 °C)). This setting ensures an economical and comfortable DHW generation. Consult your local water department or municipality for further information.

ECO button

The default setting is DHW priority; the ECO button is not lit. In order to switch between **DHW tank priority** and **alternating operation**, press the ECO button.

• DHW priority

First, the DHW tank is heated up to the set temperature. The appliance then goes into heating mode. Therefore, it can happen that space heating is interrupted for a while and the room temperature may drop.

DHW tank priority guarantees highest DHW comfort.

• Alternating operation

The appliance switches between space heating mode and DHW mode. This prevents the room from cooling off too much. Alternating operation guarantees an even room temperature with somewhat less DHW convenience.

8.7 ZWB...-3A appliances (combi boilers): Setting the DHW temperature

- ▶ Set the DHW temperature on the DHW thermostat . The set DHW temperature flashes on the display for 30 seconds.

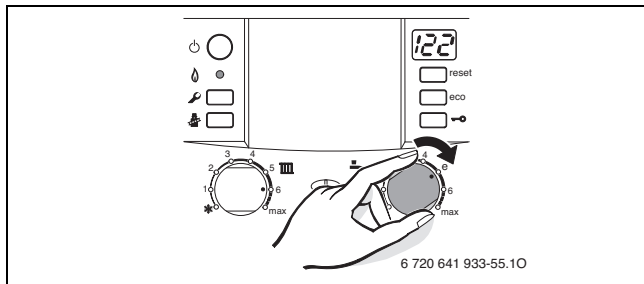

Fig. 70 Set the DHW temperature (ZWB...-3A)

DHW thermostat 	Typical DHW temperatures
min	approx. 104 °F (40 °C)
e	approx. 122 °F (50 °C)
max	approx. 140 °F (60 °C)

Table 25 Typical DHW temperatures for ZWB...-3A appliances

ECO button

Pressing and holding the ECO button until it lights up switches between **Comfort mode** and **Economy mode**.

- **Comfort mode (default setting)**
The appliance is continually maintained at the set temperature. Consequently, DHW draws are immediate, however the appliance may run even if no DHW is being drawn.
- **Economy mode, ECO button lights up**
 - DHW is only generated when DHW is drawn.
 - **On demand:** Quickly open and close a DHW tap to signal the appliance to heat to the selected temperature. After a short wait DHW will be available.



The DHW on demand signal allows maximum gas and water savings.

8.8 Setting manual summer mode

In summer mode or warm weather shut down (WWSD), the heating zone pump and consequently central heating are switched off. DHW generation remains active following the DHW program.



See also the warm weather shutdown (WWSD) feature in the operating instructions for the heating control included in the scope of delivery.

NOTICE

Heating system at risk of freezing.

In manual summer mode, only the appliance is protected from freezing.

- ▶ Observe frost protection measures where there is a risk of frost (→ chapter 8.9).
- ▶ Note the supply temperature controller setting .

- ▶ Turn the boiler high limit dial  counterclockwise as far as it will go: .

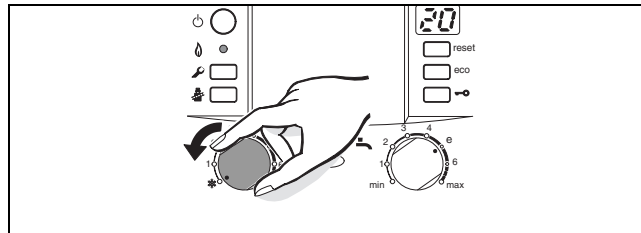

Fig. 71 Summer mode

For further information, see the operating instructions for the heating control included in the scope of delivery.

8.9 Setting frost protection

Frost protection of the heating system:

- ▶ Leave the appliance switched ON; set the boiler high limit to at least 95 °F (35 °C) (position 1, → Tab. 22, page 50).

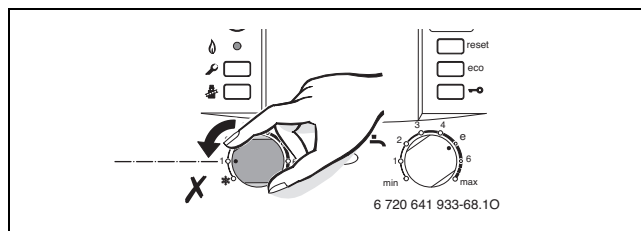

Fig. 72 Frost protection of the heating system

-or-

- ▶ If you want to leave the appliance switched OFF: Mix Bosch-approved anti-freeze into the heating water (→ Tab. 28, page) and drain the DHW circuit.



For further information, see the operating instructions for the heating control included in the scope of delivery.

Frost protection of the DHW tank:

- ▶ Leave the appliance switched ON; set the boiler high limit to at least 95 °F (35 °C) (position 1, → Tab. 22, page 50).
- ▶ Turn the DHW thermostat  counterclockwise as far as it will go (50 °F (10 °C)).

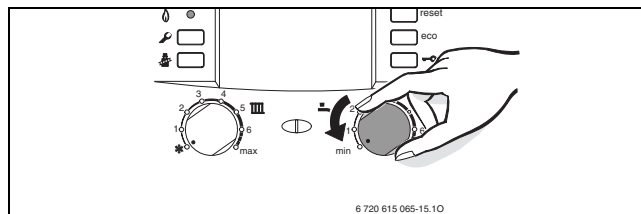



Fig. 73 Frost protection for the DHW tank

8.10 Activating the key pad lock

The key pad lock affects the boiler high limit dial, the DHW thermostat, and all buttons except the ON/OFF switch, emissions test button, and reset button. It can be used to limit unauthorized access to the boiler.

Activating the key pad lock:

- ▶ Press the key pad lock button until  and the heating supply temperature are alternating on the display.

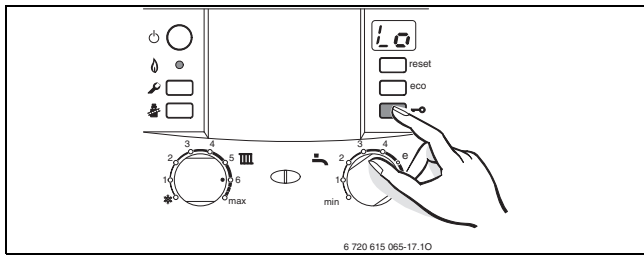

Fig. 74 Key pad lock

Unlocking the key pad:

- ▶ Press the key pad lock button until the display shows only the supply temperature.

9 ZBR...-3A appliances (heating boiler) with DHW tank: Thermal disinfection

Thermal disinfection covers the DHW system including the taps. For solar DHW tanks, the solar portion of the tank is not covered.

WARNING

Risk of scalding!

Hot water can result in severe scalding.

- ▶ Carry out thermal disinfection only outside the normal hours of use, or install a tempering valve.
- ▶ Close all DHW taps.
- ▶ Advise occupants of the risk of scalding if no tempering valve is installed.
- ▶ Set the time and DHW temperature accordingly on the heating control with DHW program.
- ▶ Set any DHW recirculation pump to continuous operation.
- ▶ Turn DHW thermostat clockwise to **max** (approx. 158 °F (70 °C)).

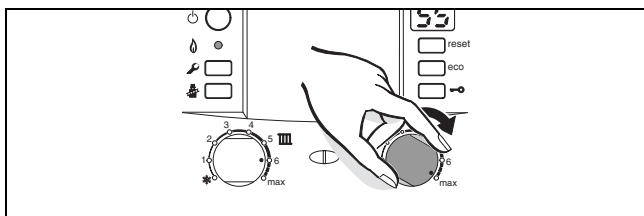

Fig. 75 Thermal disinfection

- ▶ Wait until the maximum temperature has been reached.
- ▶ Open all DHW taps, from the nearest to the one furthest away, and draw off hot water until it reaches a minimum of 158 °F (70 °C) at all taps for at least 3 minutes.
- ▶ Reset the DHW thermostat, DHW recirculation pump, and heating control to standard operation.

i

Thermal disinfection can also be carried out automatically and on a regular basis; see operating instructions for the heating control included in the scope of delivery.

10 Boiler circulator

10.1 Pump anti-seize protection

i

This function prevents the heating zone pump from seizing up following longer idle periods.

The appliance will briefly run the pump at least every 24 hours after its last activation.

10.2 Changing the pump curve of the boiler pump

The speed of the boiler pump can be changed using the dial on the pump.

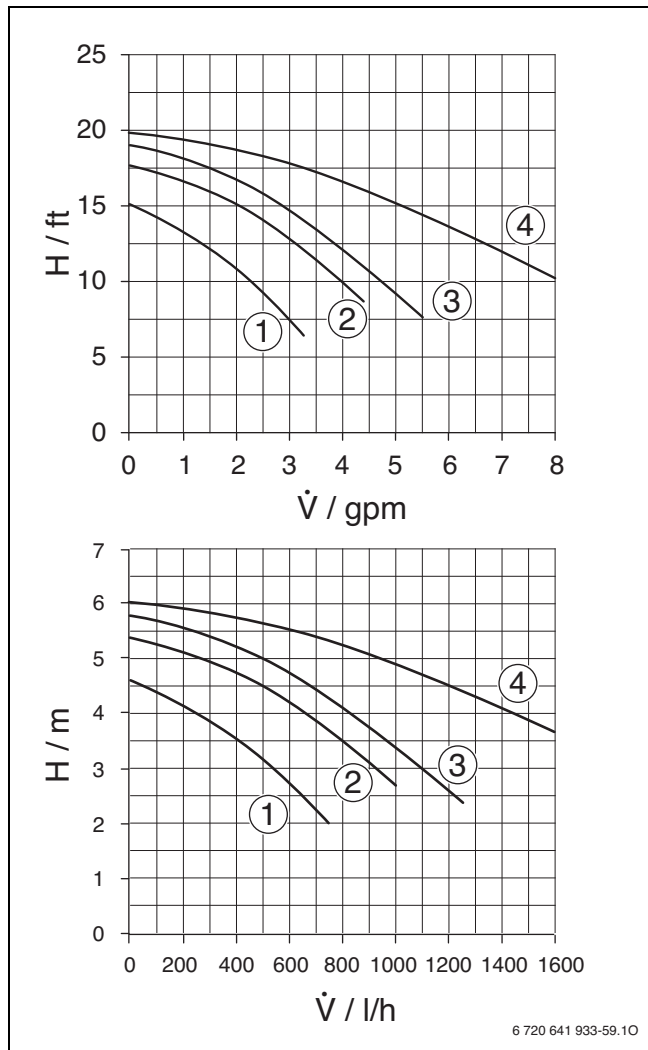

Fig. 76 Pump curve of the boiler pump heating boiler ZBR...-3A

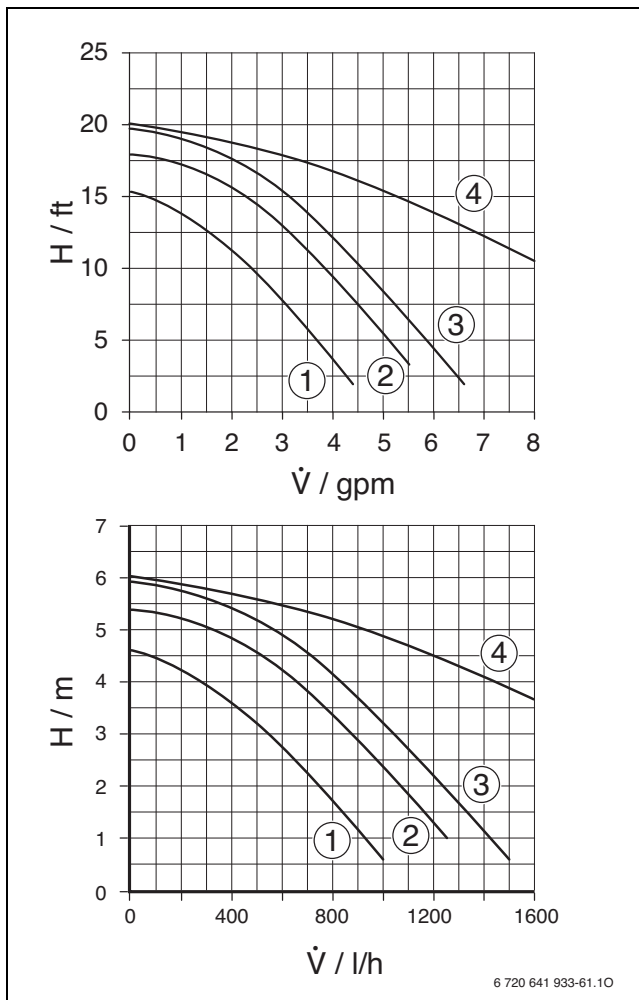

Fig. 77 Pump curve of the boiler pump combi boiler ZWB...-3A

Key to Fig. 76 and Fig. 77:

- [1] Residual head pressure at speed 1
- [2] Residual head pressure at speed 2
- [3] Residual head pressure at speed 3 (default setting)
- [4] Head pressure of the boiler pump by itself (at speed 3)
- H Head pressure in feet of head (m)
- \dot{V} Circulating water volume in gallons per minute (l/h)



In order to save as much energy as possible and keep any water circulation noises to a minimum, select the lowest possible pump speed.

11 Heatronic boiler control settings

11.1 Guideline to service functions

The Heatronic allows easy setting and testing of many appliance functions.

For an overview of service functions, see Chapter 11.2 on page 56.

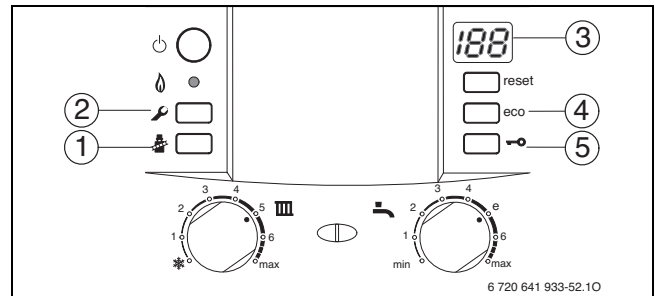

Fig. 78 Overview of the controls

- [1] Emissions test button
- [2] Service button
- [3] Display
- [4] ECO button, service functions “up”
- [5] Key pad lock, service functions “down”

Selecting a service function

The service functions are subdivided into two levels: The **1st level** includes service functions **up to 0.E**, the **2nd level** includes service functions **starting with 8.A**.

- ▶ Press and hold the service button until it lights up. The display shows a code such as 1.A (first service level).
- ▶ Repeatedly press the key pad lock button or ECO button to scroll to the desired service function.
- ▶ Press and release the emissions test button . The chimney sweep button lights up and the display shows the setting for the selected service function.

Adjust Value

- ▶ Repeatedly press the key pad lock button or ECO button to adjust the value up or down.
- ▶ Record the value in the commissioning log (→ page 78).

Saving the value

- ▶ Press and hold the emissions test button until the display shows (value saved).



The unit automatically exits the service level if no button is pressed for 15 minutes.

Exiting the service function without saving values

- ▶ Briefly press the emissions test button . The light of the emissions test button will go out.

Restoring factory settings

In order to reset all values for the service levels 1 and 2 to the factory setting:

- ▶ Press and hold the service button until it lights up. The display shows a code such as 1.A (first service level). Press the button and key pad lock button simultaneously until the code 8.A appears (second service level).
- ▶ On the second service level, select the service function 8.E and value **00**. The appliance restarts with the default settings.

11.2 Overview of the service functions

11.2.1 First service level (press and hold the service button until it lights up)

Service function		
Display		Page
1.A	Maximum space heating output	57
1.b	Maximum DHW output	57
1.E	Pump mode for space heating operation	57
1.F	Pump mode	57
2.A	Heating circuit pump lockout time	57
2.b	Maximum supply temperature	57
2.C	Purging function	57
2.d	Thermal disinfection	58
2.F	Operating mode	58
3.A	Automatic anti-cycle function	58
3.b	Set anti-cycle time	58
3.C	Switching differential (hysteresis)	58
3.d	Minimum output (heating and DHW)	58
3.E	Cycle time, keeping DHW hot	58
3.F	Constant DHW period	59
4.b	Maximum heat exchanger temperature	59
4.d	Audible fault warning tone	59
4.E	Appliance type	59
4.F	Condensate trap filling sequence	59
5.A	Reset inspection interval	59
5.b	Fan post purge time	59
5.E	Functionality of black plug in boiler junction box	59
5.F	Set inspection interval	59
6.A	Display the latest fault code	59
6.b	Room temperature control, current voltage, terminal 2	59
6.C	Supply temperature required by outdoor reset control	60
6.d	Current DHW turbine flow rate	60
7.A	Indicator lamp for burner operation / faults	60
7.b	3-way valve in center position	60
7.d	Connecting an external supply or low-loss header temperature sensor	60
7.E	Building drying function	60
0.A	Do not use this setting!	60
0.d	Altitude adjustment	60
0.E	Metric or US customary units	60
P0	Weather depending control off/on, summer mode	60
P1	Base temperature of the heating curve	60
P2	Slope of the heating curve	60

Table 26 Service functions, 1st level

11.2.2 Heating curve

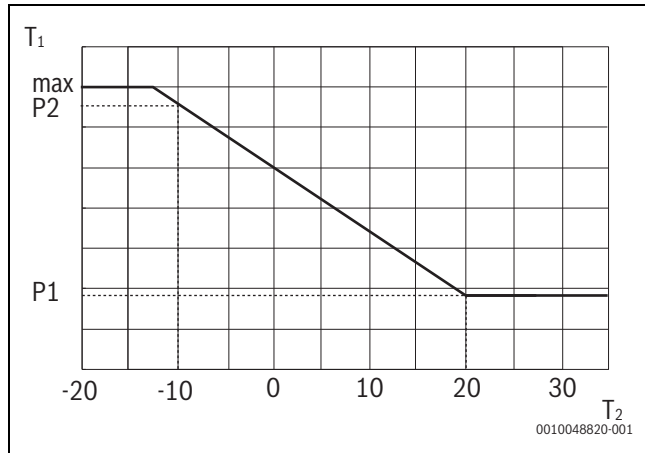

Fig. 79 Heating curve

- P1 Base temperature of the heating curve
- P2 Slope of the heating curve
- T₁ Weather depending set point in °C
- T₂ Average outdoor temperature in °C

11.2.3 Second service level (at first service level, service button lights up, press ECO button and key pad lock button simultaneously until 8.A appears)

Service function		
Display		Page
8.A	Software version	61
8.b	Code plug number	61
8.C	GFA Gas burner control status ^a	61
8.d	GFA fault	61
8.E	Restore boiler to factory settings	61
8.F	Permanent ignition	61
9.A	Constant mode	61
9.b	Current fan speed	61
9.C	Current boiler output	61
9.d	Set fan start speed	61
9.E	Turbine signal delay	61
9.F	Heating zone pump post purge	61
A.b	Display DHW temperature	61
A.C	Display DHW tank temperature	61
b.F	Solar DHW backup heating delay	61
C.d	Display current heat demand	61

a. GFA: Gas burner control unit

Table 27 Service functions, 2nd level

11.3 Description of the service functions

11.3.1 First service level

Service function 1.A: Maximum space heating output

Some gas supply companies offer a performance-dependent basic price.

The output can be limited in percent between the minimum and maximum nominal output to suit the specific heat demand.



Even if the heating output has been limited, the maximum nominal output is still available for DHW generation.

- ▶ Select service function 1.A.
- ▶ Select heat output in MBH (kW) and determine associated setting in percent (%).
- ▶ Enter the setting (→ Chapter 10.1).
- ▶ Save the setting (→ Chapter 10.1).
- ▶ Record the set heat output in the commissioning log (→ page 78).
- ▶ Exit the service functions.
The display returns to the supply temperature.

The **factory setting** is the maximum nominal output: **100** (100 %).

Service function 1.b: Maximum DHW output

The hot water output can be adjusted between the minimum and maximum DHW outputs to suit the heat transfer capacity of the DHW tank coil.

- ▶ Select service function 1.b.
- ▶ Select the DHW output in MBH (kW) and determine the associated setting in percent (%).
- ▶ Enter the setting (→ 11.1).
- ▶ Save the setting (→ 11.1).
- ▶ Record the set DHW output in the commissioning log (→ page 78).
- ▶ Exit the service functions.
The display returns to the supply temperature.

The **factory setting** is the maximum nominal output: **100** (100 %).

Service function 1.E: Pump mode for space heating operation



If an outdoor temperature sensor for an outdoor reset control is connected, pump control mode 04 is automatically set.

- **Pump control mode 00 (automatic mode):** The BUS control controls the central heating pump.
- **Pump control mode 01:** For heating systems without control. When there is a demand for heat, the central heating pump and the burner start up.
- **Pump control mode 02:** Do not use.
- **Pump control mode 03:** The central heating pump runs continuously (exceptions: See heating control operating instructions).
- **Pump control mode 04:** Intelligent control of central heating pump in heating systems with outdoor reset control. The heating zone pump is only switched on when needed.

Default setting is **00**.

Service function 1. F: Pump mode (only heating boiler ZBR...-3A)

NOTICE

System damage or boiler malfunction!

- ▶ Never change the setting of this service function on combi boiler ZWB...-3A appliances.

Based on this setting, the pump connected to the Heatronic or 3-way valve are controlled according to the configuration of the heating system.

The following settings are possible:

- **Pump mode 00:** The appliance is used only as central heating boiler.
- **Pump mode 01:** A 3-way valve for DHW tank loading is connected in boiler circuit before low loss header.
- **Pump mode 02:** Do not use this setting!
- **Pump mode 03:** A DHW tank pump is connected on the system side after the low loss header.
In DHW mode, DHW tank loading pump runs.
In space heating mode, DHW tank loading pump does not run.

Default setting is **03**.

Service function 2.A: Heating circuit pump lockout time (only heating boiler ZBR...-3A)

NOTICE

System damage or boiler malfunction!

- ▶ Never change the setting of this service function on combi boiler ZWB...-3A appliances.



This setting is only active if Service function 1. F: Pump mode is set to 01 (3-way valve).

During the runtime of an external 3-way valve actuator, the space heating pump is blocked. Select the run time of the 3-way valve actuator between **01 - 24** (10 - 240) seconds according to the manufacturer's documentation.

Default setting is **24** (240 seconds).

Service function 2.b: Maximum supply temperature

The values of this service function displayed depend on the setting of the service function **0.E**:

Service function **0.E** is set to **00** (metric units):

- The maximum supply temperature can be adjusted between **35** and **86** (35 - 86 °C).

Service function **0.E** is set to **01** (US customary units):

- The maximum supply temperature can be adjusted between **96** and **187** (96 - 187 °F).

Default setting is **187** (187 °F (86 °C)).

Service function 2.C: Purging function



When the appliance is switched ON for the first time, it performs a once-only purging sequence. This involves the heating zone pump switching on and off at intervals (for approx. 4 minutes).

The display shows  in alternation with the supply temperature.



This service function allows activating the purging function manually, e.g. after servicing.

The following settings are possible:

- **00**: Purging function off
- **01**: Purging function is switched on and after completion automatically reset to **00**
- **02**: Purging function is permanently on and is not reset to **00**

Default setting is **00** for heating boilers ZBR...-3A appliances, otherwise **01**.

Service function 2.d: Thermal disinfection (legionella protection)



WARNING

Danger of scalding!

Hot water can scald.

- ▶ Carry out thermal disinfection only outside the normal hours of use.
- ▶ Install a tempering valve if running at water temperatures above 104 °F (40 °C).

When this service function is enabled, the DHW is **permanently** heated to approx. 158 °F (70 °C) if the DHW temperature dial has been turned clockwise to **max**.

The following settings are available:

- **00**: Thermal disinfection not enabled
- **01**: Thermal disinfection enabled

Default setting is **00** (disabled).

Service function 2.F: Operating mode

With this service function, you can temporarily change the appliance's operating mode.

The following settings are available:

- **00**: Default mode; the appliance runs according to control settings.
- **01**: The appliance runs for 15 minutes at minimum output. The display shows 2.F. When this service function is aborted or has been active for 15 minutes, the appliance reverts to default mode.
- **02**: The appliance runs for 15 minutes at maximum output. The display shows 2.F. When this service function is aborted or has been active for 15 minutes, the appliance reverts to default mode.

Default setting is **00**.

Service function 3.A: Automatic anti-cycle function



If an outdoor reset control is connected, there is no need to adjust this setting on the appliance.

The control automatically optimizes the anti-cycle time.

Use service function 3.A to set the automatic adaptation of the anti-cycle time. This can be required in case of unfavorably-dimensioned heating systems. Short cycling may increase boiler and system wear and tear, increase emissions, reduce comfort, and should be avoided. With auto-adaptation of the anti-cycle time disabled, the anti-cycle time must be set using service function 3.b (→ page 58).

The following settings are available:

- **00**: Automatic adaptation of the anti-cycle time is disabled
- **01**: Automatic adaptation of the anti-cycle time is enabled

Default setting is **00** (switched off).

Service function 3.b: Set anti-cycle time

Only if the automatic anti-cycle time is disabled (service function 3.A) will this function be active.



If an outdoor reset control is connected, there is no need to adjust this setting on the appliance.

The control automatically optimizes the anti-cycle time.

The anti-cycle time can be set from **00** to **15** (0 to 15 minutes).

With **00**, the anti-cycle lock is switched off.

The shortest possible switching interval is 1 minute (recommended for single zone or forced air heating systems).

Default setting is **03**.

Service function 3.C: Switching differential

Only if the automatic anti-cycle time is disabled (service function 3.A) will this function be active.



If an outdoor reset control is connected, there is no need to adjust this setting on the appliance.

The control automatically optimizes this setting.

The switching differential is the permitted boiler differential from the target supply temperature. It can be set in increments of 1 °F (0.5 °C). The minimum supply temperature is 95 °F (35 °C).

Service function **0.E** is set to **00** (metric units):

- You can set the switching differential between **00** and **30** (0 - 30 °C).

Service function **0.E** is set to **01** (US-customary units):

- You can set the switching differential between **00** and **54** (0 - 54 °F).

Default setting is **18** (18 °F (10 °C)).

Service function 3.d: Minimum output (heating and DHW)

The output for heating and DHW can be set to any level in percent between the minimum and maximum nominal output.

The **default setting** is the minimum nominal output (heating and DHW) and varies according to appliance.

Service function 3.E: Cycle time, keeping DHW hot (only combi boiler ZWB...-3A)

NOTICE

System damage or boiler malfunction!

- ▶ Never change the setting of this service function on heating boiler ZBR...-3A appliances.

This service function is only active in comfort mode.

It specifies the time from completion of preheating or DHW demand until the next time the plate-type heat exchanger is heated up. This prevents the plate-type heat exchanger from overheating.

The cycle time can be set from **20** to **60** minutes.

Default setting is **20** (20 minutes).

Service function 3.F: Constant DHW period (only combi boiler ZWB...-3A)

NOTICE

System damage or boiler malfunction!

- ▶ Never change the setting of this service function on heating boiler ZBR...-3A appliances.

The constant DHW period specifies how long the space heating mode remains disabled after DHW is drawn.

The duration for keeping DHW hot can be set from **00** to **30** (0 to 30 minutes).

Default setting is **01** (1 minute).

Service function 4.b: Maximum heat exchanger temperature (only combi boiler ZWB...-3A)

NOTICE

System damage or boiler malfunction!

- ▶ Never change the setting of this service function on heating boiler ZBR...-3A appliances.

This function can be used to reduce limestone built-up in the heat exchanger, which increases with temperature. The maximum heat exchanger temperature can be set in steps of 1 °F (0.5 °C).

Service function **0.E** is set to **00** (metric units):

- The maximum temperature for keeping the heat exchanger hot can be set from **40** to **65** (40 to 65 °C).

Service function **0.E** is set to **01** (US-customary units):

- The maximum temperature for keeping the heat exchanger hot can be set from **104** to **150** (104 to 150 °F).

Default setting is **140** (140 °F (60 °C)).

Service function 4.d: Audible fault warning tone

The appliance can be set to sound an audible alarm to alert the operator of a fault present. The audible warning tone can be deactivated with the service function 4.d.

00: Warning tone off

01: Warning tone on

Default setting is **01** (ON).

Service function 4.E: Appliance type

This service function displays the appliance type detected.

Available displays are:

- **00:** Central heating only
- **01:** Combi appliance
- **02:** DHW tank temperature sensor () connected to Heatronic.
- **03:** DHW tank thermostat connected to Heatronic.
- **04:** Stratified DHW tank
- **05:** Tank with NTC return

Service function 4.F: Condensate trap filling sequence

DANGER

Risk of flue gas poisoning.

If the condensate trap is not filled, flue gas may escape from the dry trap.

- ▶ Only deactivate the trap filling sequence for servicing purposes.
- ▶ When servicing is complete, reactivate the trap filling function.

The trap filling sequence ensures that the condensate trap is filled after initial installation or after a longer downtime of the appliance.

The trap filling sequence is activated if:

- The appliance is switched OFF using the ON/OFF switch
- The burner has not been in use for at least 28 days
- You are switching between summer and winter mode

The next time there is a demand for heat in central heating or hot water mode, the appliance is held at low output for 15 minutes. The trap filling sequence remains active until the appliance has completed 15 minutes of operation at low output. The display shows  alternating with the supply temperature.

The following settings are available:

- **00:** Condensate trap filling sequence is off.
- **01:** Trap filling program at the lowest output.
- **02:** Trap filling sequence at set minimum output.

Default setting is **01**.

Service function 5.A: Reset inspection interval

This function enables you to reset the indication  on the display after completing inspection/servicing of the appliance.

Default setting **00**.

Service function 5.b: Fan post purge time

This service function allows setting the time the fan purges after the burner is shut off.

The post purge time can be set from **01** to **18** (10 - 180 seconds).

Default setting is **03** (30 seconds).

Service function 5.E: Functionality of black plug in boiler junction box

With this service function you can set the functionality of the black plug in the boiler junction box.

The following settings are possible:

- **00:** Off - black connector in junction box is disabled (120VAC output deactivated).
- **01:** DHW recirculation pump enabled - See Bosch room controller instructions on how to set a recirculation pump program.
- **02:** External heating zone pump in heating circuit without 3-way valve.
- **03:** External heating zone pump in heating circuit without mixer controlled by Heatronic running in parallel with boiler pump in central heating mode

Default setting is **03**.

Service function 5.F: Set inspection interval

This service function allows you to set the number of months after which the 'service due' indication  (Inspection) alternates on the display with the supply temperature.

The number of months can be set from **00** - **72** (0 to 72 months).

Default setting is **00** (disabled).

Service function 6.A: Display the latest fault code

Use this service function to display the most recent fault code.

Service function 6.b: Room temperature control, current voltage, terminal 2

The current voltage of the analog control at terminal 2 is displayed.

Available displays are:

- **00** - **24:** 0 V to 24 V in increments of 1 V

Service function 6.C: Supply temperature required by outdoor reset control

This service function allows displaying the current target supply temperature set by the outdoor reset control.

Service function 6.d: Current DHW turbine flow rate (only combi boiler ZWB...-3A)

NOTICE

System damage or boiler malfunction!

- ▶ Never change the setting of this service function on heating boiler ZBR...-3A appliances.

The current flow rate of the DHW turbine is displayed.

Service function **0.E** is set to **00** (metric units):

- **0.0. - 99.9.:** 0.0 to 99 l/min in increments of 0.1 l/min

Service function **0.E** is set to **01** (US-customary units):

- **0.0. - 99.9.:** 0.0 to 99 gpm in increments of 0.1 gpm

Service function 7.A: Indicator lamp for burner operation / faults

With this service function you can activate and deactivate the indicator lamp for burner operation (continuously illuminated) and faults (flashing).

The following settings are available:

- **00:** Off
- **01:** On

Default setting is 00.

Service function 7.b: 3-way valve in center position

After the value **01** has been saved, the 3-way valve moves to the center position. This allows draining the system completely and removing the motor easily.

When you exit this service function, the appliance returns to setting **00**.

Service function 7.d: Connecting an external supply or low-loss header temperature sensor

Presence of an external supply or low loss header temperature sensor is automatically detected by default; you do not need to change any settings.



If a sensor is disconnected, change the setting back to the default setting **00**.

The following settings are available:

- **00:** Once-only automatic detection of a sensor
- **01:** External supply temperature sensor connected to Heatronic.
- **02:** External supply temperature sensor connected to CZM100.

Default setting is 00.

Service function 7.E: Building drying function

This service function allows you to start and stop the building drying function.



When the building drying function is on, you cannot adjust the appliance gas settings.

The following settings are available:

- **00:** Off
- **01:** Heating operation only in accordance with the appliance or control setting, i.e. all other heat demands are blocked.

Default setting is 00.

Service function 0.A: Do not use this setting!

Default setting is 00 (disabled).

Service function 0.d: Altitude adjustment

Input and output rates are reduced at higher altitudes due to thin air with reduced oxygen levels.

ZBR42-3A... and ZWB42-3A... appliances are derated at 3 % per 1000 feet (305 m).

ZBR21-3A..., ZBR28-3A..., ZBR35-3A..., ZWB28-3A... and ZWB35-3A... appliances offer altitude adjustment which compensates for the effects of thin air, and are therefore NOT derated up to 6000 feet (1829 m). Above 6000 feet (1829 m) a rate of 3 % per 1000 feet (305 m) applies.

This service function is used to adjust the fan speed for high altitude operation.

The following settings are available:

- **00:** Normal
- **01:** Medium
- **02:** High

Setting	Elevation above sea level
00	0 – ft2,000 ft (0 m – 610 m)
01	2,001 ft – 4,500 ft (611 m – 1 372 m)
02	above 4,500 ft (1 372 m)

Table 28 Altitude adjustment (service function 0.d)

Default setting is 00.

Service function 0.E: Metric or US customary units

With this service function you can set if Metric or US customary units are displayed on the boiler.

The following settings are available:

- **00:** °C, l/min (metric units)
- **01:** °F, gpm (US-customary units)

Default setting is 01.

Service function P0: Weather depending control off/on, summer mode

The following settings are available:

- **32 °F (0 °C):** Weather depending control off
- **33 °F- 86 °F (1-30 °C):** Weather depending control on. Temperature limit in summer mode when heating switches off.

Default: 32 °F (0 °C)

Service function P1: Base temperature of the heating curve

The following settings are available:

- **68 °F (20 °C)...122 °F (50 °C)**

Default: 68 °F (20 °C)

Service function P2: Slope of the heating curve

The following settings are available:

- **104 °F (40 °C)...194 °F (90 °C)**

Default: 188 °F (88 °C)

→ For the heating curve, see fig. 79.

11.3.2 Second service level

Service function 8.A: Software version

The current software version is displayed.

Service function 8.b: Code plug number



The last four digits of the code plug number are shown. The code plug determines the appliance functions. If the appliance has been converted from natural gas to LPG (or vice versa), the code plug must be replaced.

Service function 8.C: GFA Gas burner control unit status





Internal parameter. If you are on the line with Bosch Technical Support you may be asked for this number.

Service function 8.d: GFA Gas burner control unit fault

Internal parameter.

Service function 8.E: Restore boiler to factory settings

This function allows resetting all parameters of the boiler including all service functions to their factory settings.

- ▶ Press and hold the service button  until it lights up. The display shows a code such as 1.A (first service level).
- ▶ Press and hold button and key pad lock button simultaneously until a service function, e.g. 8.A, is displayed (second service level).
- ▶ Repeatedly press the key pad lock button or button until service function 8.E is displayed.
- ▶ Press and release the emissions test button . The emissions test button  lights up and the display shows 00.
- ▶ Press and hold the emissions test button  until the display shows  appears on the display. All settings are reset and the appliance restarts with the default settings.
- ▶ Reset altered service functions to the settings recorded in the commissioning log (→ page 78).

Service function 8.F: Permanent ignition

NOTICE

Ignition transformer damage.

- ▶ Never leave this function on for longer than 2 minutes at a time.

This function enables permanent ignition without gas supply to test the performance of all ignition related components.

The following settings are available:

- 00: Off
- 01: On

Default setting is 00.

Service function 9.A: Constant mode

This function permanently sets one operating mode ("Service function 2.F: Operating mode", page 58).

The following settings are available:

- 00: Default mode: the appliance runs according to control settings.
- 01: The appliance runs permanently at minimum output. The display shows 9.A.
- 02: The appliance runs permanently at maximum output. The display shows 9.A.

Default setting is 00.

Service function 9.b: Current fan speed

This service function allows you to display the current fan speed in revolutions per second (1/s).

Service function 9.C: Current boiler output

This service function displays the current boiler output (in percent (%)).

Service function 9.d: Set fan start speed

At higher elevations the boiler fan may need to spin faster upon startup to ensure reliable ignition every time. The start speed of the boiler fan can be set from 45 to 77 revolutions per second (1/s).

Default setting is 50.

Service function 9.E: Turbine signal delay (only combi boiler ZWB...-3A)

NOTICE

System damage or boiler malfunction!

- ▶ Never change the setting of this service function on heating boiler ZBR...-3A appliances.

This service function allows setting a time delay to prevent the appliance starting up as a result of transient pressure spikes in the water supply.

Through spontaneous pressure change in the water supply, the flow meter (turbine) can signal that DHW is being drawn and cause the burner to come on unnecessarily.

The turbine signal delay can be set from 02 to 08 (0.5 seconds to 2 seconds) in increments of 0.25 seconds.

Default setting is 04 (1 second).

Service function 9.F: Heating zone pump post purge

This service function allows setting a pump post purge time after the end of the heat demand from the external control.

The pump post purge time can be set from 01 to 10 (1 to 10 minutes).

Default setting is 03.

Service function A.b: Display DHW temperature

This service function allows displaying the current DHW temperature.

Service function A.C: Display DHW tank temperature

This service function allows displaying the temperature of the DHW tank temperature sensor.

Service function b.F: Solar DHW backup heating delay (only combi boiler ZWB...-3A)

For systems with a solar thermal DHW tank in series before the DHW line of the combi boiler. DHW heating by the boiler will be suppressed expecting that solar thermal DHW will reach the hot water temperature sensor prior eliminating the need to run the boiler. Set the heating delay in accordance with system conditions.



If this setting is enabled, the DHW demand signal is no longer available → page 52.

The start delay can be set between 00 to 50 (0 to 50 seconds) in increments of 1 second.

Default setting is 00.

Service function C.d: Display current heat demand

Available displays are:

- 00: No heat demand
- 01: Space heating demand present
- 02: DHW heat demand present

12 Gas adjustment

DANGER

Personal injury and property damage

- ▶ This conversion shall only be performed by a trained and certified installer in accordance with the manufacturer's instructions and all applicable codes and requirements of the authority having jurisdiction.
- ▶ If the information in these instructions is not followed exactly, or the installation, adjustment, modification, operation or maintenance is carried out by an unqualified person, a fire, explosion or generation of large amounts of carbon monoxide may result causing property damage, personal injury or loss of life.
- ▶ Always disconnect the appliance from the mains power before performing any work. Always disconnect the appliance from the mains power before performing any work. Take measures to prevent accidental reconnection.
- ▶ The installer is responsible for the proper conversion of this appliance.
- ▶ The conversion is not complete until the operation of the converted appliance is checked as specified in these instructions.

Adjustment to different flue systems using throttle discs or baffles is not necessary.

NG

- The appliances are set at the factory to a Wobbe index of 1.333 BTU/ft³ (49.6 MJ/m³) at 60 °F (approx. 15 °C), a gas supply pressure of 30" HG and 7.0" W.C. (17.4 mbar), and then sealed.

12.1 Converting to a different gas type

WARNING

Risk of fatal injury from explosion!

Escaping gas can cause an explosion.

- ▶ Allow only a licensed contractor to work on parts that carry gas.
- ▶ Close the gas shut-off valve before working on parts that carry gas.
- ▶ Replace used seals with new seals.
- ▶ After completing the work on parts that carry gas, carry out a leak test.

A gas conversion kit with instructions for gas conversion is included in the scope of delivery.

- ▶ Follow the instructions from the conversion kit.

With the gas conversion kit there is no setting of the gas/air ratio (CO₂ or O₂) necessary.

12.2 Installation location higher than 2,000 feet (610 m) above sea level

Input and output rates are reduced at higher altitudes due to thin air with reduced oxygen levels.

ZBR 42-3A... and ZWB 42-3A... appliances are derated at 3% per 1000 feet (305 m).

ZBR 21-3A..., ZBR 28-3A..., ZBR 35-3A..., ZWB 28-3A... and ZWB 35-3A appliances offer altitude adjustment which compensates for the effects of thin air, and are therefore NOT derated up to 6000 feet (1829 m). Above 6000 feet (1829 m) a rate of 3% per 1000 feet (305 m) applies.

The wall mounted gas condensing boiler is factory set for installation below 2000 feet (610 m) above sea level.

- ▶ Correction of the fan speed curve of the burner:
Use service function 0.d to adjust the elevation setting (→ page 60).

12.3 Checking and setting the gas-air ratio (CO₂ or O₂), if required

- ▶ Switch the appliance OFF using the ON/OFF switch.
- ▶ Remove the cover (→ page 32).
- ▶ Switch the appliance ON using the ON/OFF switch.
- ▶ Open one of the flue gas test ports.

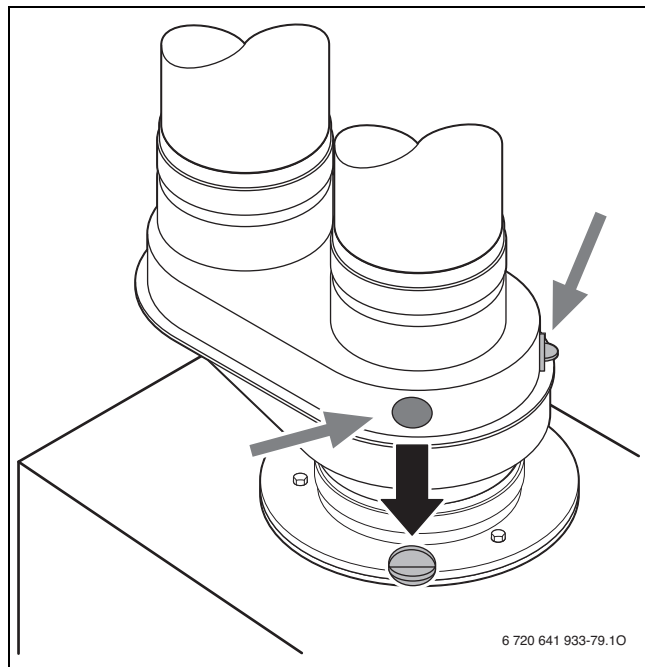





Fig. 80 Open one of the flue gas test ports

- ▶ Insert the probe approx. 2-3/4 inches (70 mm) into the test port and seal around it.
- ▶ Press and hold the emissions test button  until it lights up. The supply temperature alternates on the display with  = **maximum set output in heating mode.**
- ▶ Briefly press the emissions test button . The supply temperature alternates on the display with  = **maximum nominal output.**

- ▶ Measure the CO₂ or O₂ level and the CO content of the flue gas (→ Section 13).
- ▶ On the gas throttle, break the seal at the slot and remove the cap.

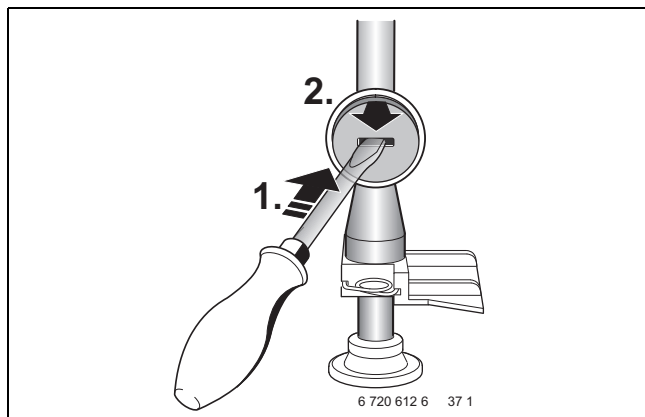

Fig. 81 Remove seal from the gas throttle

- ▶ Adjust the gas throttle to set the CO₂ or O₂ level for maximum nominal output according to the table 29.

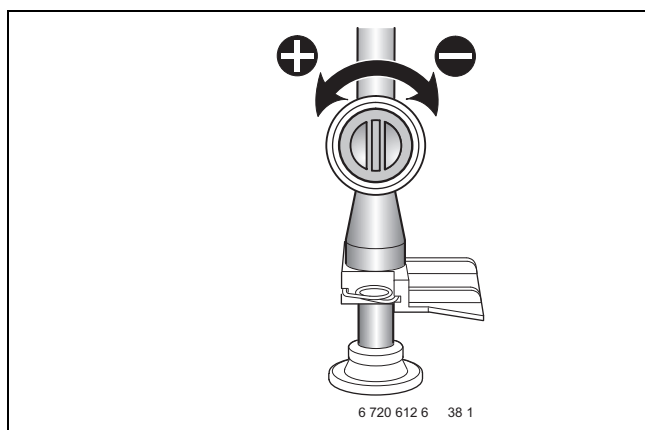

Fig. 82 Set CO₂ or O₂ level for maximum nominal output

Gas type	Maximum nominal output		Minimum nominal output	
	CO ₂	O ₂	CO ₂	O ₂
NG	9.4 %	4.0 %	8.6 %	5.5 %
LPG (propane)	11.0 %	4.2 %	10.4 %	5.1 %

Table 29 CO₂ or O₂ values at maximum and minimum nominal output

- ▶ Briefly press the emissions test button . The supply temperature alternates on the display with = **minimum nominal output**.
- ▶ Measure the CO₂ or O₂ level and the CO content of the flue gas (→ Section 13).

- ▶ Remove screw (→ Fig. 83, [3]) from the gas valve adjustment screw (→ Fig. 83, [2]) and set CO₂ or O₂ value for minimum nominal output.

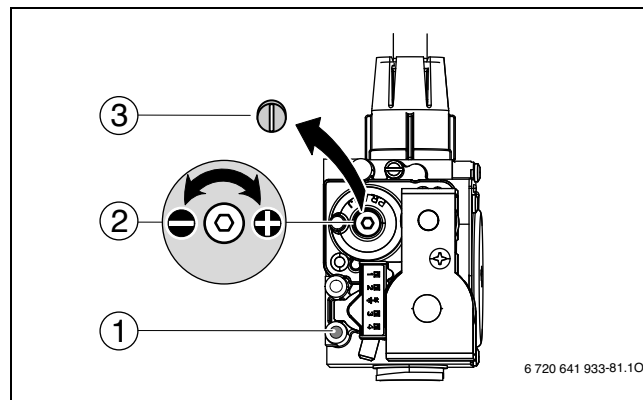

Fig. 83 Setting the CO₂ or O₂ values for minimum nominal output

- ▶ Re-check settings at maximum and minimum nominal output and re-adjust if necessary.
- ▶ Repeatedly press the emissions test button until the light goes out. The display returns to the supply temperature.
- ▶ Record the CO₂ or O₂ levels and the CO content of the flue gas in the commissioning log.
- ▶ Reinstall screw (→ Fig. 83, [3]) to cover the adjustment screw (→ Fig. 83, [2]) on the gas valve again.
- ▶ Remove flue gas probe and close the flue gas test port properly.

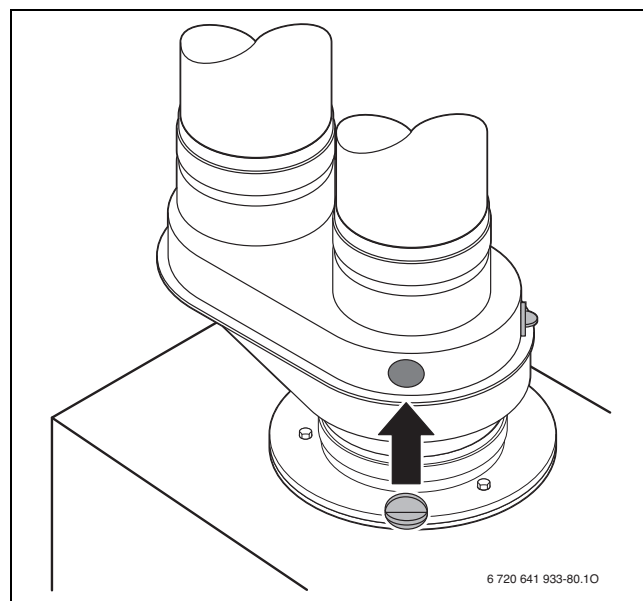

Fig. 84 Close flue gas test ports

12.4 Dynamic gas pressure test port

- ▶ Switch the appliance OFF and close the gas shut-off valve.
- ▶ Loosen the screw in the test port for gas inlet pressure (→ Fig. 52, [1]) and connect a pressure gauge (→ Fig. 85).

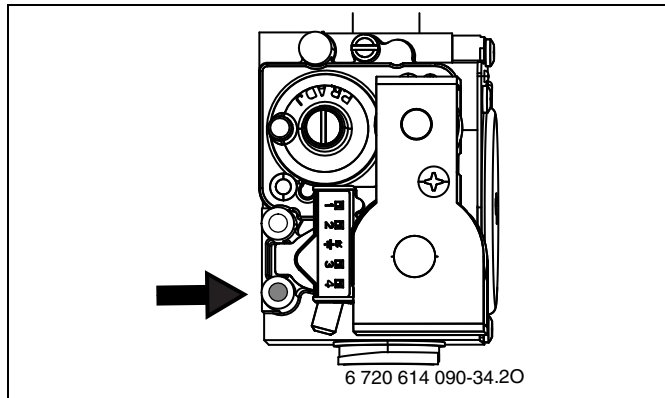

Fig. 85 Dynamic gas pressure test port

- ▶ Turn on the gas cock and switch the appliance ON.
- ▶ Press and hold the emissions test button until it lights up. The supply temperature alternates on the display with = **maximum set heat output**.
- ▶ Briefly press the emissions test button chimney sweep button. The supply temperature alternates on the display with = **maximum nominal output**.
- ▶ Check the required inlet gas pressure according to table 30.

Gas type	Nominal pressure " W.C. (mbar)	Permissible pressure range for maximum nominal output " W.C. (mbar)
NG	7 (17.4)	3.5-10.5 (8.7-26.1)
LPG (propane)	11 (27.4)	8-13 (19.9-32.3)

Table 30 Inlet gas pressure



Do not operate the appliance if the measured value is below or above these values. Determine the cause and eliminate the fault. If this is not possible, block the appliance on the gas side and notify the gas supplier.

- ▶ Repeatedly press the emissions test button until the light goes out. The display returns to the supply temperature.
- ▶ Switch the appliance OFF, turn off the gas cock, remove the pressure gauge and tighten the screw in the test port for gas inlet pressure.
- ▶ Reinstall the cover.

13 Flue gas test

13.1 Emissions test button

The following appliance outputs can be selected by pressing the emissions test button until it lights up:

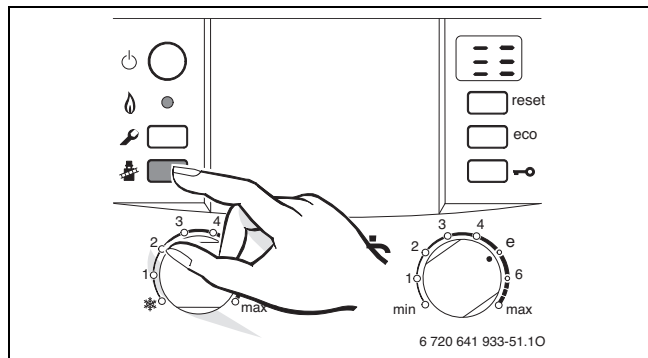

Fig. 86 Press the emissions test button

- = **Maximum set output in heating mode** (Maximum heating output, page 57)
- = **maximum nominal output**
- = **Minimum nominal output**



You have 15 minutes to complete the tests. After that, the appliance returns to default mode.

13.2 Measuring CO content of flue gas

Use a multiport flue gas probe for the measurements.

- ▶ Remove plug from flue gas test port (→ Fig. 80).
- ▶ Insert the flue gas probe approx. 2-3/4 inches (70 mm) into the test port and seal around it.
- ▶ Press the emissions test button to select = **maximum nominal output**.
- ▶ Measure the CO levels.



Risk of flue gas poisoning.

The CO level in the flue gas must be below 200 ppm (air free).

- ▶ If 9.4 Vol.%¹⁾ CO₂ and a CO level under 200 ppm (af) can not be achieved due to the gas supplied, use a lower CO₂ level with CO emissions under 200 ppm (af) instead.

- ▶ Repeatedly press the emissions test button until the light goes out. The display returns to the supply temperature.
- ▶ Remove the flue gas probe and seal the flue gas test port properly (→ Fig. 84).

1) 9.4 Vol.% with NG and 11.0 Vol.% with LPG (propane)

14 Environmental protection and disposal

Environmental protection is one of the fundamental company policies of the Bosch Group.

Quality of products, efficiency and environmental protection are equally important objectives for us. Environmental protection laws and regulations are strictly adhered to.

To protect the environment, we use the best possible technology and materials taking into account economic points of view.

Packaging method

For the packaging, we participate in the country-specific recycling systems, which guarantee optimal recycling.

All packaging materials used are environmentally-friendly and recyclable.

Old appliances

Old appliances contain valuable materials that can be recycled. The components are easy to separate. Plastics are identified. This allows the various assemblies to be sorted and recycled or disposed of.

15 Inspection and maintenance

Regular service and maintenance are recommended for a long service life of the appliance, for efficient and economical operation, and to keep the environmental impact as low as possible.

DANGER

Explosion!

- ▶ Close the gas cock prior to working on the gas train.
- ▶ Check for gas leaks after carrying out work on the gas train.

DANGER

Risk of flue gas poisoning.

- ▶ Check for leaks after carrying out work on the venting system.

DANGER

Risk of electric shock!

- ▶ Always disconnect the appliance from the mains power before performing any work. Always disconnect the appliance from the mains power before performing any work. Take measures to prevent accidental reconnection.

NOTICE

Insufficient antifreeze can accelerate corrosion.

- ▶ Frost protection level has to be checked annually during the regular scheduled maintenance of the condensing boiler.

Heat exchanger

NOTICE

Damage to the coating of the heat exchanger.

- ▶ Cleaning of the heat exchanger should not be necessary until five years after the initial commissioning.
- ▶ Only use a Bosch cleaning blade and Bosch cleaning brush.
- ▶ Only clean heat exchanger when visibly dirty.

Heatronic boiler control

In case of a component defect, a fault is shown on the display.

The Heatronic boiler control monitors all safety and control components.

NOTICE

The Heatronic boiler control can be damaged by leaking water.

- ▶ Cover the Heatronic prior to working on water filled components.

Important notes



An overview of the faults can be found on page 74.

- The following analytical tools are needed for service and maintenance:
 - Electronic flue gas analyzer for CO₂, O₂, CO, and flue gas temperature (0 to 30 mbar)
 - pH Test strips
 - Glycol tester of antifreeze is being used
 - Special tools are not required.
 - Approved lubricants are:
 - For parts touched by water: Unisilikon L 641 (part-# 8 709 918 413 0)
 - or fittings: HFt 1 v 5 (part-# 8 709 918 010 0).
 - ▶ Use part-# 8 719 918 658 0 as heat conducting paste.
 - ▶ Use only genuine Bosch spare parts.
 - ▶ Request spare parts.
 - ▶ Replace removed gaskets and O-rings with new ones.
-  After the inspection/maintenance**
- ▶ Re-tighten all loosened threaded connections.
 - ▶ Restart the appliance (→ Chapter 8, page 49).
 - ▶ Check all joints for leaks.
 - ▶ Check the gas-air ratio.

15.1 Description of various steps

15.1.1 Calling up the latest fault (service function 6.A)

- ▶ Select service function 6A (→ page 59).



An overview of the faults can be found on page 74.

15.1.2 Fresh water filter (only combi boiler ZWB...-3A)

- ▶ Close cold water tap.
- ▶ Depressurize the cold water pipe.
- ▶ To access the filter remove the safety clip (step 1), pull out the pipe (step 2), and remove the filter from the pipe (step 3).
- ▶ If necessary, clean with plastic brush under running water.

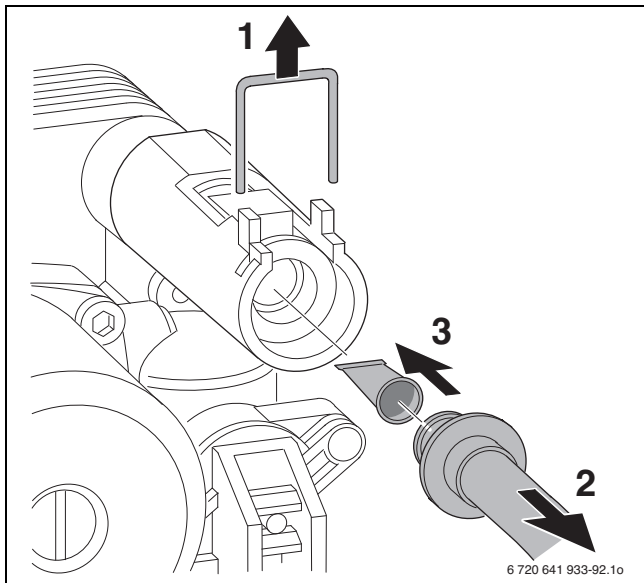

Fig. 87 Filter in fresh water pipe

15.1.3 Plate type heat exchanger (only combi boiler ZWB...-3A)

If the DHW output on the combi boiler is significantly reduced:

- ▶ Check filter in the cold water pipe for contamination (→ page 66).
- ▶ Depressurize the appliance.
- ▶ Remove plate type heat exchanger and replace

-or-

- ▶ Descale with descaling agent approved for stainless steel (Grade 316-1.4401).

To remove the plate type heat exchanger:

- ▶ Unplug electrical connections.
- ▶ Remove hose from safety relief valve.

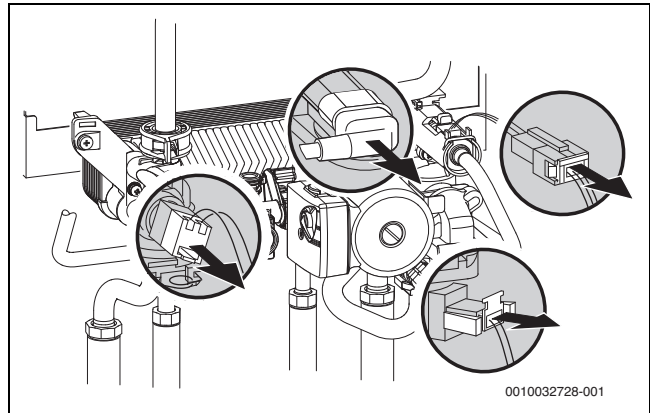

Fig. 88 Unplugging electrical connections / removing hose from safety relief valve

- ▶ Loosen/remove pipe connections.

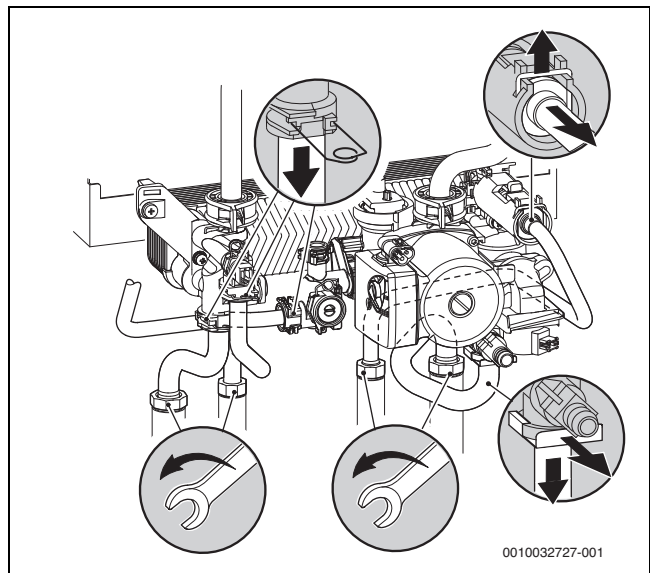

Fig. 89 Removing pipe connections

- ▶ Remove the boiler pressure gauge from the Heatrionic boiler control.

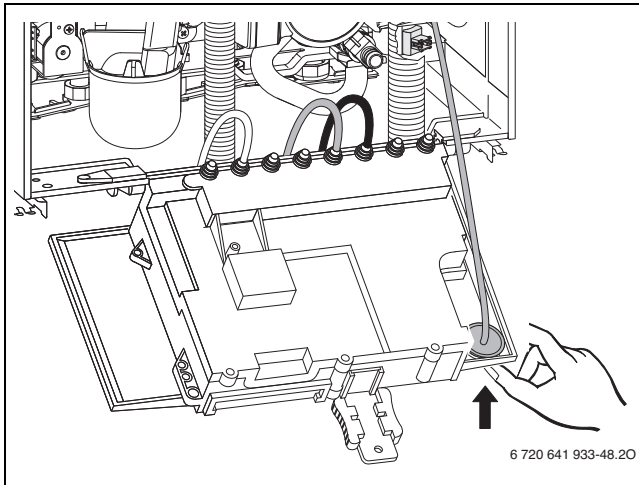

Fig. 90 Removing the boiler pressure gauge

- ▶ Loosen the quick releases (steps 1 and 2) and remove the hydraulic assembly in its entirety (step 3).

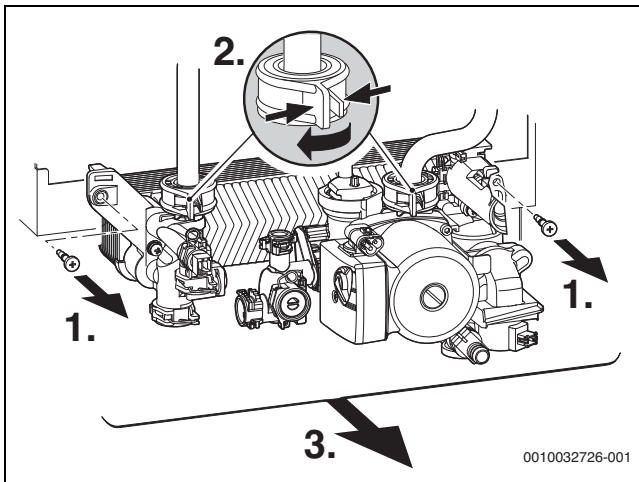

Fig. 91 Removing the hydraulic assembly

- ▶ Remove the plate type heat exchanger.

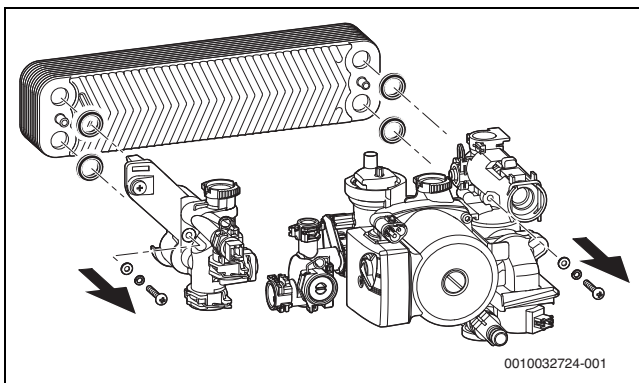

Fig. 92 Removing the plate heat exchanger

- ▶ Install new plate type heat exchanger with new gaskets and reconnect the hydraulic assembly in reverse order.
- ▶ Check all connections used during maintenance for leaks.

15.1.4 Checking electrodes

- ▶ Remove electrode set including gasket and check electrodes for contamination; clean or replace, if required.
- ▶ Reinstall electrode set with new gaskets and check for leaks.

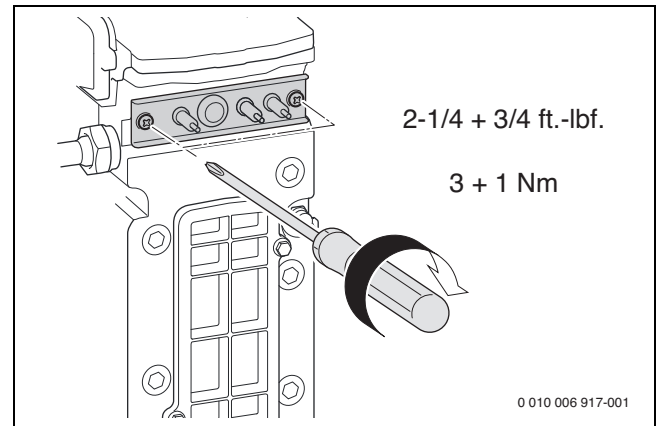

Fig. 93 Reinstalling the electrode set

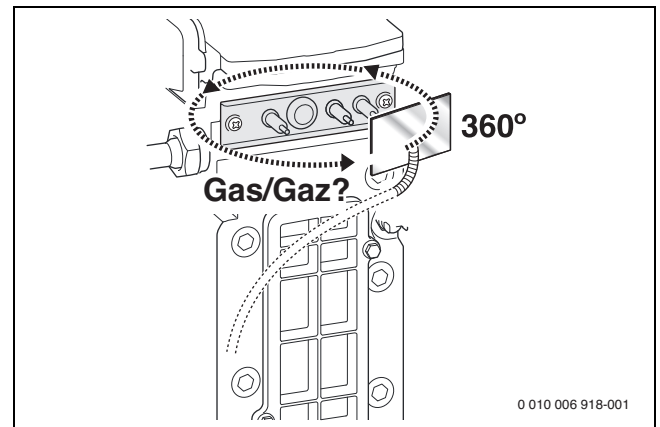

Fig. 94 Check for leaks

15.1.5 Burner servicing

! DANGER

Fire danger!

- ▶ The burner may be operated only while installed in a wall-mounted gas condensing boiler.

- ▶ Remove burner lid (steps 1 - 4).

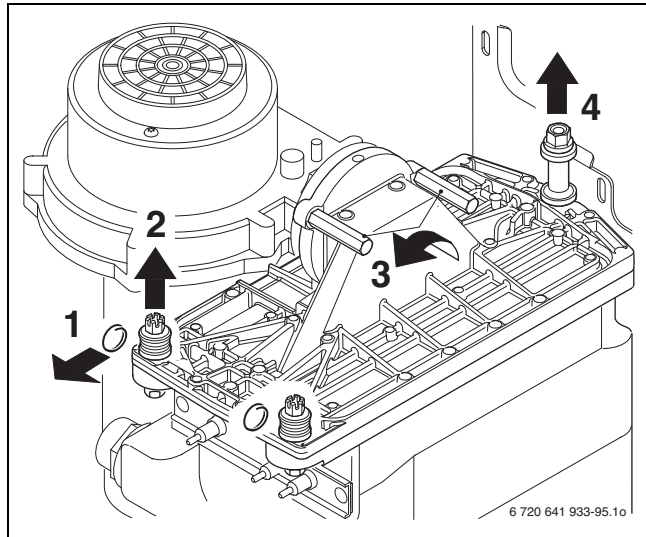

Fig. 95 Removing the burner cover

- ▶ Remove burner and clean its components.

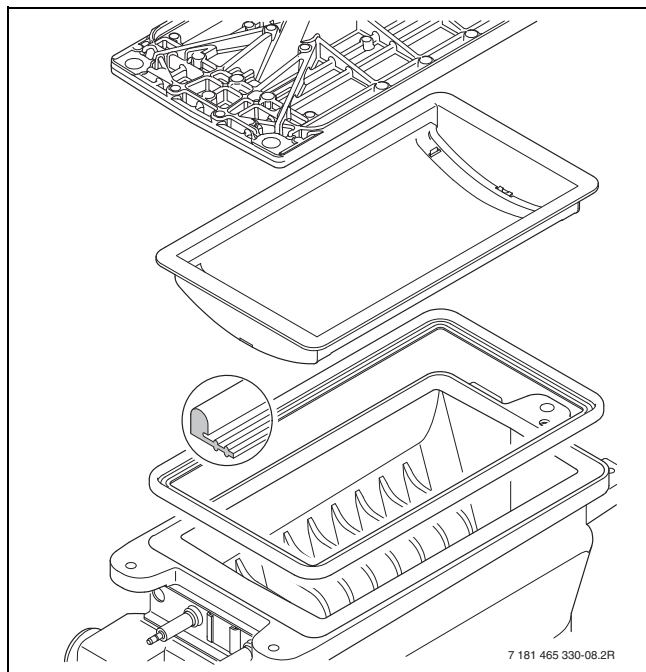

Fig. 96 Burner

- ▶ Reinstall burner in reverse order, including a new gasket if necessary.
- ▶ Adjust the gas-air ratio (→page 62)

15.1.6 Heat exchanger block inspection and cleaning

NOTICE

Damage to the coating of the heat exchanger.

- ▶ Cleaning of the heat exchanger should not be necessary until five years after the initial commissioning.
- ▶ Only use a Bosch cleaning blade and Bosch cleaning brush.
- ▶ Only clean heat exchanger when visibly dirty.

- ▶ Remove the inspection cover (→ page 8) and any sheet metal insert below, if installed.
- ▶ Determine degree of soiling of the heat exchanger through visual inspection.

If mechanical cleaning is required:

To clean of the heat exchanger, use Bosch burner gaskets, cleaning brush kit and cleaning blade, all of which are available as spare parts.

- ▶ Remove the condensate trap (steps 1 and 2) and place a suitable container underneath.

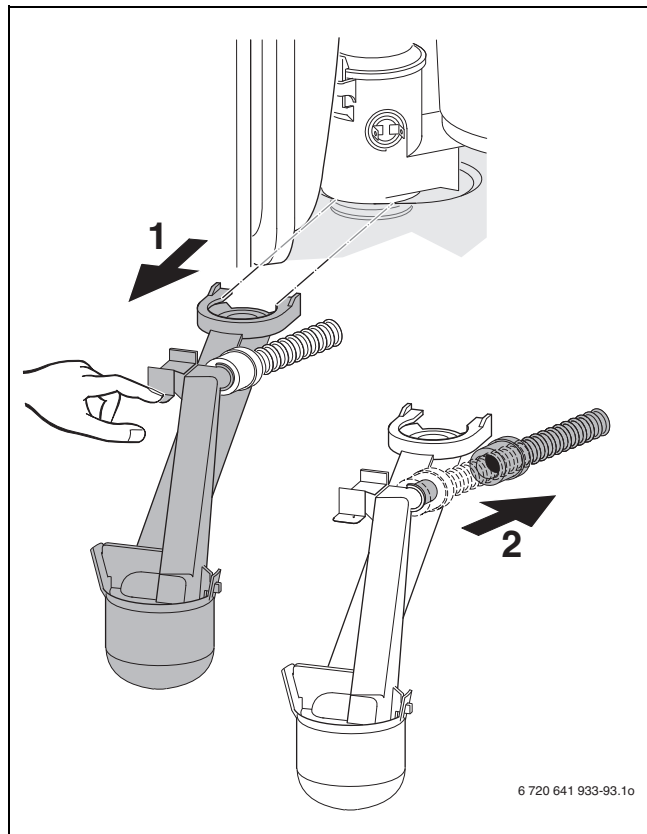

Fig. 97 Removing the condensate trap

- ▶ With the cleaning blade, clean the heat exchanger block from the bottom to the top.

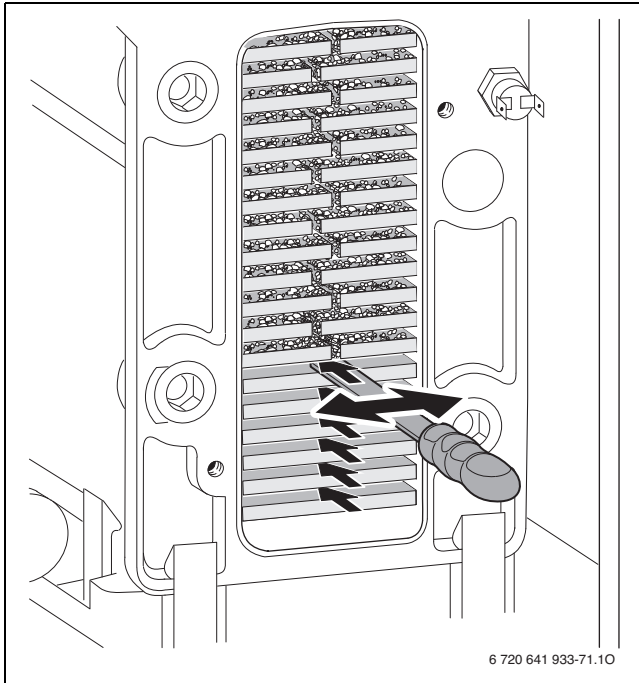

Fig. 98 Cleaning the heat exchanger with the cleaning blade

- ▶ Clean the heat exchanger block with the brush from top to bottom.

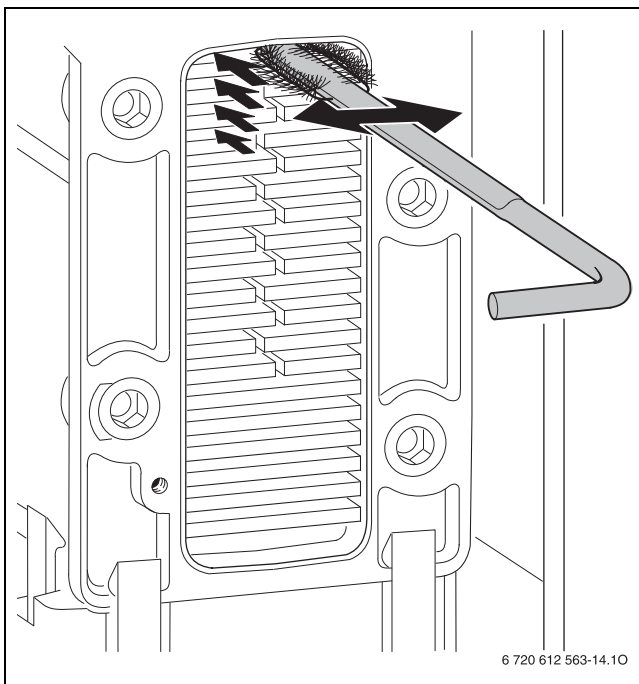

Fig. 99 Cleaning the heat exchanger with the cleaning brush

- ▶ Remove burner (→ Chapter 15.1.5 “Burner servicing”).

- ▶ Rinse the heat exchanger with water from the top.

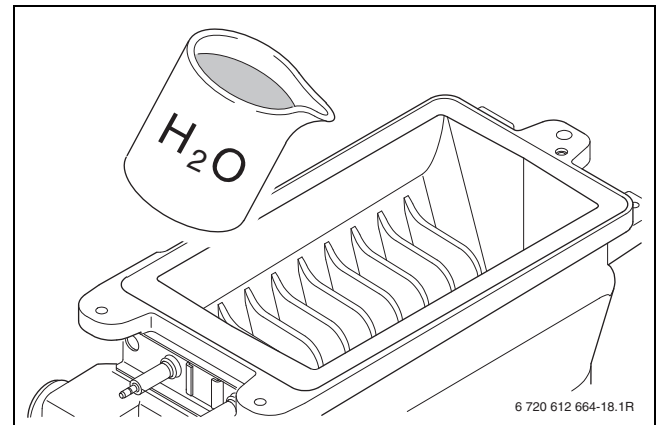

Fig. 100 Rinsing the heat exchanger

- ▶ Clean the condensate tray (with reversed brush).

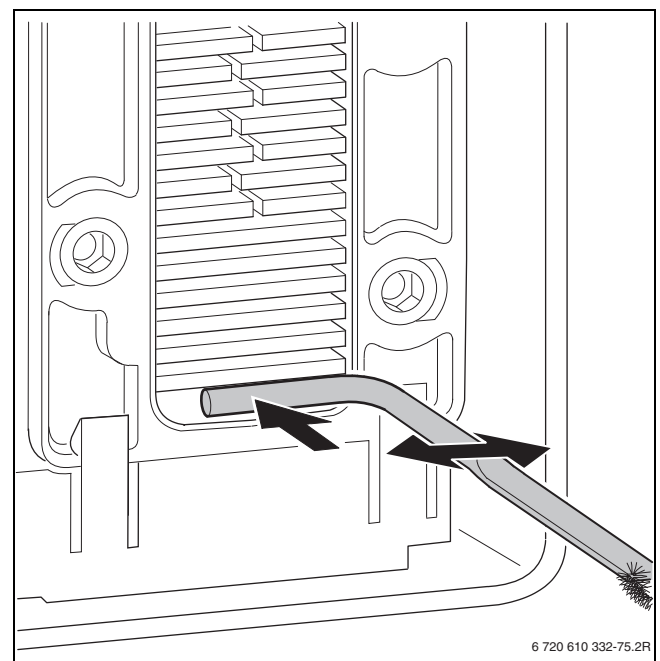

Fig. 101 Cleaning the condensate tray

- ▶ Rinse the heat exchanger with water from the top.
- ▶ Clean the condensate trap connection.
- ▶ Close the inspection opening again using a new gasket and tighten the screws with a torque between 4.1 ft-lbs (5.5 Nm) and 5.1 ft-lbs (7.0 Nm).

15.1.7 Cleaning condensate trap

- ▶ Remove condensate trap (steps 1 and 2) and check heat exchanger orifice for clear passage.

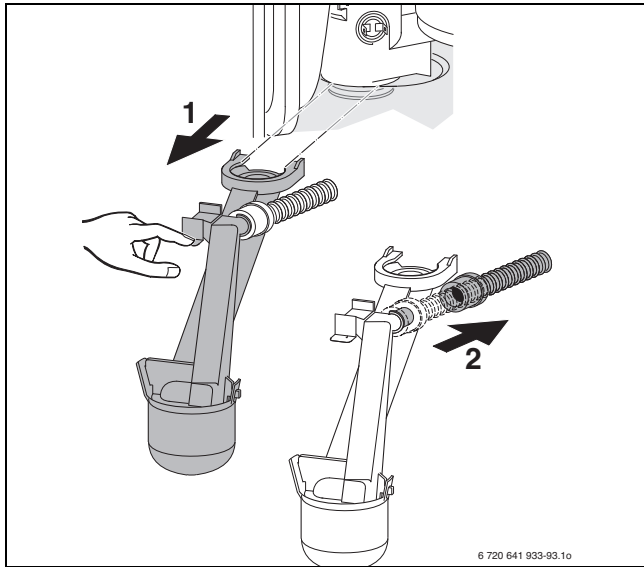

Fig. 102 Removing the condensate trap

- ▶ Remove and clean the condensate trap lid.
- ▶ Check condensate hose and clean if necessary.
- ▶ Fill the condensate trap with approx. 1 cup (1/4 l) of water and reinstall it.

15.1.8 Checking the mixer diaphragm

- ▶ Open the mixer unit.
- ▶ Carefully remove the diaphragm from the fan air intake and check for contamination and cracks.

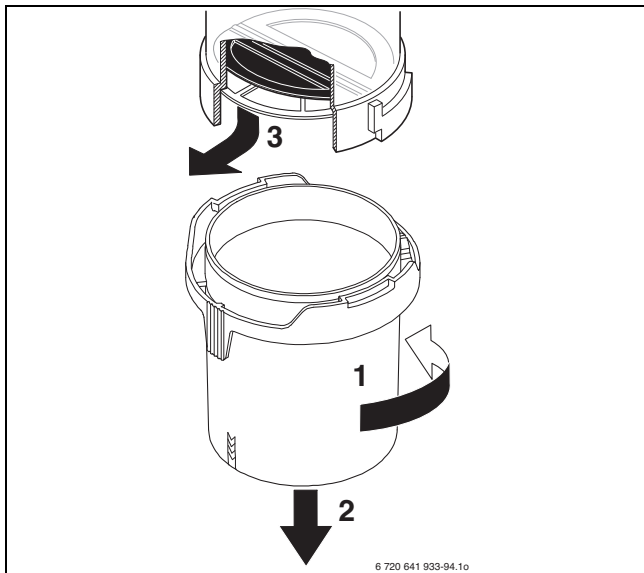

Fig. 103 Opening the mixer unit

- ▶ Insert the diaphragm into the fan connector.



The diaphragm flaps must open upwards.

- ▶ Close the mixer unit.

15.1.9 Checking the expansion vessel

Annual inspection of the expansion vessel is required.

- ▶ Depressurize the appliance.
- ▶ If necessary, adjust the expansion vessel pre-charge pressure to the static head of the heating system.

15.1.10 Setting the boiler water pressure

Display on the pressure gauge	
14.5 psi (1 bar)	Minimum filling pressure (when system is cold)
14.5 psi to 21.75 psi (1 bar to 1.5 bar)	Optimal filling pressure
30 psi (2.07 bar)	Maximum pressure at maximum heating water temperature must not be exceeded (safety valve will spill).

Table 31 Operating pressure

- ▶ If the indicator is below 14.5 psi (1 bar) when the system is cold, top up the water. The indicator must be between 14.5 psi (1 bar) and 21.75 psi (1.5 bar).



If using a hose to fill the heating system, prefill the hose with water to prevent air being introduced into the system.

- ▶ If the pressure is not held, check the expansion vessel and heating system for leaks.

15.1.11 Testing system water quality

- ▶ Take a representative sample of the system water and analyze pH using a pH meter or pH test strips.

pH-value	Water preparation
7-8.5	Not needed
4.5-7	Required

Table 32 Water preparation for filling and maintaining the heating system (pH-value)

- ▶ If the value is outside of the permitted range, drain the system, flush, and refill with fresh water to prevent system damage or leaks.
- ▶ If the fill water does not meet the requirements of page 28, treat the water to bring it within the permissible range.
- ▶ If antifreeze is being used in the system, check the frost protection properties to ensure the site specific requirements are met.

15.1.12 Checking the electrical wiring

- ▶ Check electrical wiring for mechanical damage and replace defective cables.

15.2 Maintenance and inspection checklist

- Use this form to guide you through the service and maintenance procedure. Fill out each step according to the findings and work performed.

Date →							
1	Latest fault code from service function 6.A.						
2	Fresh water inlet filter (Combi boiler ZWB appliances only).						
3	Visual inspection of the combustion air pipes and vent pipes.						
4	Dynamic gas pressure	inches W.C. (mbar)					
5	Gas-air ratio at min./max. nominal output.	min. % max. %					
6	Gas and water-side leak test.						
7	Inspect electrodes.						
8	Inspect heat exchanger block.						
9	Check burner.						
10	Inspect diaphragm in mixer unit.						
11	Clean condensate trap.						
12	With the system depressurized, check the expansion vessel pre-charge pressure vs. the static head of the heating system.	psi (bar)					
13	Check the heating system filling pressure.	psi (bar)					
14	Inspect electrical wiring for damage.						
15	Check settings of the heating control.						
16	Check set service functions according to commissioning report.						

Table 33 Maintenance and inspection checklist

16 Readings on the display

The 7-segment display shows the following:

Value displayed	Description	Range
Number or letter, dot followed by letter	Servicefunction (→ Tab. 26/ 27, page 56/ 56)	
Letter followed by number or letter	Fault code (→ Tab. 36, page 74) (exception: b.A = service function)	
Three numbers (≤ 199)	Decimal value, e.g. supply temperature	00 ... 199
One number (displayed for longer) followed by two numbers (displayed briefly)	Decimal figure (three digits); first digit is shown alternating with two last digits (e.g. 2.69..69 for 269)	0 ... 999
Two dashes followed by two pairs of numbers	Code is shown in three stages: 1. Two dashes 2. First two digits 3. Last two digits (e.g. -- 10 04)	1000 ... 9999
Two letters followed by two pairs of numbers	Code is shown in three stages: 1. Two letters 2. First two CF 10 digits 3. Last two digits (e.g. 20)	

Table 34 Display readings























Status code	Description
	Acknowledge by pressing any button (except reset).
	Acknowledge by pressing two buttons simultaneously
	Acknowledge by pressing the button  and holding longer than 3 seconds (Save function).
	The display shows the supply temperature in alternation with  . The appliance works for 15 minutes at the minimum nominal output, service function 2.F .
	The display shows the supply temperature in alternation with  . The appliance works with the set maximum output in heating mode, service function 1.A .
	The display shows the supply temperature alternating with  . The appliance works for 15 minutes at the maximum nominal output, service function 2.F .
	The air purging function is active, service function 2.C
	The display shows the supply temperature alternating with  . The trap filling sequence is active, service function 4.F .
	The display shows the supply temperature alternating with  : Service due, → service function 5.A .
	The display shows the supply temperature alternating with  . The pump has seized, → fault E9 .
	The display shows the supply temperature alternating with  . The temperature gradient limiter was triggered. Excessive supply temperature increase: Heating mode is suspended for two minutes.
	Slab drying function of the FW 200 outdoor reset control (operating instructions) or building drying function (service function 7.E) are activated.
	Key pad lock enabled. To unlock the key pad, press  until the supply temperature is shown on the display.

Table 35 Special displays

17 Faults

17.1 Troubleshooting



Explosion!

- ▶ Close the gas cock prior to working on the gas train.
- ▶ Check for gas leaks after carrying out work on the gas train.



Risk of flue gas poisoning.

- ▶ Check for leaks after carrying out work on the venting system.



Risk of electric shock!

- ▶ Always disconnect the appliance from the mains power before performing any work. Always disconnect the appliance from the mains power before performing any work. Take measures to prevent accidental reconnection.



Danger of scalding!

Hot water can scald.

- ▶ Drain the appliance before working on components that are water filled.

NOTICE

Risk of system damage from freezing!

The heating system can freeze up in cold weather if it has been disabled by a fault shutdown.

- ▶ Rectify the fault immediately and restart the heating system.
- ▶ If this is not possible, protect your heating system from freezing by draining the heating system and hot water pipes at the lowest point.

NOTICE

The Heatronic boiler control can be damaged by leaking water.

- ▶ Cover the Heatronic prior to work on water filled components.

The Heatronic boiler control monitors all safety and control components.

If a fault arises during operation, an audible warning tone sounds.



Press a button to mute the warning sound.

The display indicates a fault code (e.g. ) and the reset button flashes.

If the reset button is flashing:

- ▶ press the reset button and hold it until  appears on the display. The appliance starts up again and the current supply temperature is displayed.

If the reset button is not flashing:

- ▶ Switch the appliance OFF and ON again. The appliance starts up again and the current supply temperature is displayed.



An overview of the faults can be found on page 74.

An overview of the status codes can be found on page 72.

If the fault persists:

- ▶ Check the PCB and replace if required. Adjust the service functions in accordance with the commissioning report (→ page 78).

17.2 Faults that are shown on the display

Display	Description	Elimination
A7	DHW temperature sensor defective.	<ul style="list-style-type: none"> ▶ Check temperature sensor and leads for interruptions or shorts, and replace if defective. ▶ Insert code plug correctly; replace if defective.
A8	Communication fault.	<ul style="list-style-type: none"> ▶ Check BUS communications wiring, replace if defective. ▶ Check control, replace if defective.
Ad	DHW tank temperature not detected. The DHW tank temperature sensor was recognized before the connection was lost.	<ul style="list-style-type: none"> ▶ Check DHW tank temperature sensor and connecting lead, replace if defective. ▶ Reset the boiler to the factory default settings (→ service function 8.E).
b1	Code plug not detected.	<ul style="list-style-type: none"> ▶ Insert code plug correctly; replace if defective.
b2/b3/b4/ b5/b6	Internal data error.	<ul style="list-style-type: none"> ▶ Reset boiler to the factory default setting (→ service function 8.E).
b7	Fault in the burner controls.	<ul style="list-style-type: none"> ▶ Reset boiler to factory to default setting (service function 8.E).
C6	Fan not running.	<ul style="list-style-type: none"> ▶ Check fan leads and fan, replace if defective.
CC	Outdoor temperature sensor not recognized.	<ul style="list-style-type: none"> ▶ Check outdoor temperature sensor and leads for interruptions, replace if defective. ▶ Verify the outdoor temperature sensor is connected to terminals A and F.
d3	Temperature high limit defective. External guard has tripped. Temperature limiter locked out.	<ul style="list-style-type: none"> ▶ Check temperature sensor and leads for interruptions or shorts, and replace if defective. ▶ Temperature guard TB1 has tripped. Check if jumper across 8-9 or PR-P0 is missing. ▶ Reset external temperature limiter (if installed).Reset LWCO (if installed). ▶ Reset pressure regulator (if installed).
d5	External supply temperature sensor defective (low-loss header). The external supply temperature sensor was recognized on the BUS and then reconnected to the appropriate terminal.	<ul style="list-style-type: none"> ▶ Check temperature sensor and leads for interruptions or shorts, and replace if defective. ▶ Check whether only one temperature sensor is connected; otherwise remove second temperature sensor. ▶ Reset the boiler to the factory default settings (→ service function 8.E).
E2	Supply temperature sensor defective.	<ul style="list-style-type: none"> ▶ Check temperature sensor and leads for interruptions or shorts, and replace if defective.
E3	Additional supply temperature sensor defective.	<ul style="list-style-type: none"> ▶ Check temperature sensor and leads for interruptions or shorts, and replace if defective.
E9	Heat exchanger safety high limit or flue gas temperature limiter has tripped.	<ul style="list-style-type: none"> ▶ Check flue gas safety high limit and leads for interruptions or shorts, and replace if defective. ▶ Check heat exchanger safety high limit and leads for interruptions or shorts, and replace if defective. ▶ Check the operating pressure. ▶ Check temperature limit; replace if defective. ▶ Check pump capacitor; replace pump if defective. ▶ Check PCB fuse, replace if blown (6.3 A fuse according to IEC default). ▶ Purge the appliance. ▶ Check heat exchanger on the DHW side; replace if clogged.

Display	Description	Elimination
EA	No flame detected. GFA: Safety time expired.	<ul style="list-style-type: none"> ▶ Check that ground lead is properly connected, replace if defective. ▶ Check that gas cock is open. ▶ Check inlet gas pressure; correct if needed. ▶ Check power supply. ▶ Check electrodes for visual damage; replace if defective. ▶ Check flue gas system; clean or repair if defective. ▶ Check gas/air ratio; correct if out of range. ▶ Check gas valve; replace if defective. ▶ In room air operation, check air supply or ventilation apertures. ▶ Clean condensate trap. ▶ Remove diaphragm at fan inlet connection and check for contamination or cracks. ▶ Check heat exchanger for soiling. ▶ Check gas valve; replace if defective. ▶ Insert code plug correctly; replace if defective.
F0	Internal fault	<ul style="list-style-type: none"> ▶ Press reset for 3 seconds and release. When the button is released, the appliance will restart. ▶ Check electrical plug-in contacts and ignition leads; replace PCB if defective. Check gas/air ratio; correct if out of specification.
F1	Internal data error.	<ul style="list-style-type: none"> ▶ Reset boiler to the factory default setting (→ service function 8.E).
F7	Flame detected even when burner is off.	<ul style="list-style-type: none"> ▶ Check electrodes; replace if defective. ▶ Check flue gas system; clean or repair if defective. ▶ Check PCB for moisture; dry if needed.
FA	After switching gas off: Flame is detected.	<ul style="list-style-type: none"> ▶ Check gas valve; replace if defective. ▶ Clean condensate trap. ▶ Check electrodes and leads; replace if defective. ▶ Check flue gas system; clean or repair if defective.
Fd	Reset button pressed by mistake.	<ul style="list-style-type: none"> ▶ Press reset button again. ▶ Check cable harness to safety high limit and gas cock for ground connection.
	Temperature gradient limiter: Temperature rise too fast	<ul style="list-style-type: none"> ▶ Fully open service shut-off valves. ▶ Check electrical connection between heating zone pump and Heatronic. ▶ Check pump plug connection per installation instructions. ▶ Manually test operation of heating zone pump and replace if defective. ▶ Set pump speed correctly to match maximum output.

Table 36 Faults shown on the display

17.3 Faults that are not shown on the display

Appliance faults	Elimination
Combustion noise too loud; rumbling noises	<ul style="list-style-type: none"> ▶ Insert code plug correctly; replace if defective. ▶ Check gas type. ▶ Check inlet gas pressure; adjust if defective. ▶ Check flue gas system; clean or repair if defective. ▶ Check gas/air ratio in the combustion air and flue gas; replace gas valve if defective.
Flow noises	<ul style="list-style-type: none"> ▶ Set pump speed correctly to match maximum output. ▶ Set pump mode.
Heating-up takes too long	<ul style="list-style-type: none"> ▶ Set pump speed correctly to match maximum output. ▶ Set pump mode.
Flue gas readings incorrect; CO levels too high	<ul style="list-style-type: none"> ▶ Check gas type. ▶ Check inlet gas pressure; adjust if defective. ▶ Check flue gas system; clean or repair if defective. ▶ Check gas/air ratio in flue gas; replace gas valve if defective.
Violent ignition, poor ignition	<ul style="list-style-type: none"> ▶ Check gas type. ▶ Check inlet gas pressure; adjust if defective. ▶ Check power supply. ▶ Check electrodes for visual damage; replace if defective. ▶ Check flue gas system; clean or repair if defective. ▶ Check gas/air ratio; replace gas valve if defective. ▶ Check gas valve; replace if defective. ▶ Check burner; replace if required.
DHW has unpleasant odor or has a dark color	<ul style="list-style-type: none"> ▶ Perform thermal disinfection of the DHW circuit. ▶ Replace sacrificial anode in the tank (if installed). ▶ Consult local water department.
Set supply temperature exceeded	<ul style="list-style-type: none"> ▶ Switch off automatic anti-cycle timer, i.e., set value to 0. ▶ Set the required anti-cycle timer, e.g. default setting of 3 minutes.
Condensate in air box	<ul style="list-style-type: none"> ▶ Insert diaphragm in the mixer unit per installation instructions; replace if defective.
DHW temperature is not reached (combi boiler ZWB...-3A only)	<ul style="list-style-type: none"> ▶ Insert code plug correctly; replace if defective. ▶ Check whether voltage (120 VAC) is present between terminal 1 and terminal 3; repair if defective. ▶ Check turbine; replace if defective.
Heatronic is flashing (i.e. all buttons, all display segments, burner indicator etc. are flashing)	<ul style="list-style-type: none"> ▶ Replace fuse Si 3 (24 V) (6.3 A fuse according to IEC default).

Table 37 Faults not shown on the display

17.4 Check sensor values

17.4.1 Outdoor temperature sensor

Temperature °F (°C) Testing tolerance ± 10%	Resistance Ω []
- 4 (- 20)	2,392
3 (- 16)	2,088
10 (- 12)	1,811
17 (- 8)	1,562
24 (- 4)	1,342
32 (0)	1,149
39 (4)	984
46 (8)	842
50 (10)	781
59 (15)	642
68 (20)	528
77 (25)	436

Table 38 Resistance table outdoor temperature sensor

17.4.2 Additional supply temperature limiter

Temperature (°F) °C Measuring tolerance ± 10%	Resistance [Ω]
32 (0)	33,555
50 (10)	21,232
68 (20)	13,779
86 (30)	9,128
104 (40)	6,205
122 (50)	4,298
140 (60)	3,025
158 (70)	2,176
176 (80)	1,589
194 (90)	1,177
212 (100)	886

Table 39 Resistance table supply temperature limiter

17.4.3 Supply temperature sensor, External supply temperature sensor, DHW tank temperature sensor, DHW temperature sensor

Temperature °F (°C) Testing tolerance ± 10%	Resistance [Ω]
68 (20)	14,772
77 (25)	11,981
86 (30)	9,786
95 (35)	8,047
104 (40)	6,653
113 (45)	5,523
122 (50)	4,608
131 (55)	3,856
140 (60)	3,243
149 (65)	2,744
158 (70)	2,332
167 (75)	1,990
176 (80)	1,704
185 (85)	1,464
194 (90)	1,262
203 (95)	1,093
212 (100)	950

Table 40 Resistance table NTCs

17.5 Replacement code plug

Appliance	Order number
ZBR 21-3 A NG	8 714 432 528 0
ZBR 21-3 A LPG	8 714 432 529 0
ZBR 28-3 A NG	8 714 432 502 0
ZBR 28-3 A LPG	8 714 432 507 0
ZBR 35-3 A NG	8 714 432 503 0
ZBR 35-3 A LPG	8 714 432 508 0
ZBR 42-3 A NG	8 714 432 504 0
ZBR 42-3 A LPG	8 714 432 509 0
ZWB 28-3 A NG	8 714 432 520 0
ZWB 28-3 A LPG	8 714 432 521 0
ZWB 35-3 A NG	8 714 432 524 0
ZWB 35-3 A LPG	8 714 432 525 0
ZWB 42-3 A NG	8 714 432 500 0
ZWB 42-3 A LPG	8 714 432 505 0

Table 41 Code plugs for all appliances

18 Commissioning log for the appliance

Home owner/operator:			
Last name, first name		Number, Street	
Telephone/fax		ZIP code, town	
System installer:			
Order number:			
Appliance type:		(Complete a separate log for every appliance!)	
Serial number:			
Date commissioned:			
<input type="checkbox"/> Individual appliance <input type="checkbox"/> Cascade, Number of appliances:			
Installation location: <input type="checkbox"/> Cellar <input type="checkbox"/> Attic <input type="checkbox"/> Other:			
Ventilation openings: Number:, Size: Approx.			ft ² (m ²)
Vent pipe routing: <input type="checkbox"/> Twin pipe system <input type="checkbox"/> Balanced flue system <input type="checkbox"/> Duct <input type="checkbox"/> Separate pipe routing			
<input type="checkbox"/> PVC <input type="checkbox"/> CPVC <input type="checkbox"/> PP <input type="checkbox"/> 2" <input type="checkbox"/> 3"			
Total length: Approx. ft (m) Elbows 90°: Qty Elbows 15 - 45°: Qty			
Flue checked for leaks with countercurrent: <input type="checkbox"/> Yes <input type="checkbox"/> No			
CO ₂ value in the combustion air at maximum nominal output:			%
O ₂ value in the combustion air at maximum nominal output:			%
Notes regarding under or overpressure operation:			
Gas setting and flue gas test:			
Set gas type:			
Inlet gas pressure:	" W.C. (mbar)	Gas static supply pressure:	" W.C. (mbar)
Selected maximum output:	MBH (kW)	Selected minimum output:	MBH (kW)
Gas flow rate at maximum nominal output:	gpm (l/min)	Gas flow rate at minimum nominal output:	gpm (l/min)
Net calorific value H _{iB} (per gas supplier):	MBTU/ft ³ (kWh/m ³)		
CO ₂ at max. nominal output:	%	CO ₂ at minimum nominal output:	%
O ₂ at maximum nominal output:	%	O ₂ at minimum nominal output:	%
CO at maximum nominal output:	ppm mg/kWh	CO at minimum nominal output:	ppm mg/kWh
Flue gas temperature at maximum nominal output:	°F (°C)	Flue gas temperature at minimum nominal output:	°F (°C)
Maximum measured supply temperature:	°F (°C)	Minimum measured supply temperature:	°F (°C)
System hydraulics:			
<input type="checkbox"/> Low-loss header, type:	<input type="checkbox"/> Additional expansion vessel		
<input type="checkbox"/> Heating pump:	Size/pre-charge pressure:		
<input type="checkbox"/> Hydraulic separation	Automatic air vent present? <input type="checkbox"/> Yes <input type="checkbox"/> No		
<input type="checkbox"/> DHW tank/type/Number/heating surface output:			

<input type="checkbox"/> System hydraulics checked, notes:	
Modified service functions:	
Select the modified service functions and enter the values here.	
Heating control:	
<input type="checkbox"/> Outdoor reset control	<input type="checkbox"/> Room temperature-dependent control
<input type="checkbox"/> Remote control × Qty, heating zone(s) coding:	
<input type="checkbox"/> Room temperature-dependent control × Qty, heating zone(s) coding:	
<input type="checkbox"/> Module × Qty, heating zone(s) coding:	
Other:	
<input type="checkbox"/> Heating controls set, notes:	
<input type="checkbox"/> Modified heating control settings documented in the controller operating/installation instructions	
The following work has been carried out:	
<input type="checkbox"/> Electrical connections checked, notes:	
<input type="checkbox"/> Condensate trap filled	<input type="checkbox"/> Combustion air/flue gas test carried out
<input type="checkbox"/> Function check carried out	<input type="checkbox"/> Leak test carried out on the gas and water sides
Commissioning includes checking the settings, a visual heating leak test and a functional check of the boiler and control. The system installer conducts a test of the heating system.	
The system named above has been checked to the extent described.	The documents have been handed over to the home owner/operator. The home owner/operator has been instructed regarding safety and operation of the boiler and accessories, including the need for regular scheduled maintenance. Attention has been drawn to the requirement for regular maintenance of the above-mentioned heating system.
_____ Name of service engineer	_____ Date, user's signature
_____ Date, system installer's signature	Affix the test report here.

Table 42 Commissioning log

United States and Canada

Bosch Thermotechnology Corp.
50 Wentworth Avenue
Londonderry, NH 03053
Tel. 603-552-1100
Fax 603-965-7581
www.bosch-homecomfort.us
U.S.A.

Products manufactured by
Bosch Thermotechnik GmbH
Junkersstrasse 20-24
D-73249 Wernau
www.bosch-homecomfortgroup.com

Bosch Thermotechnology Corp. reserves the right
to make changes without notice due to continuing
engineering and technological advances.